

The Players Guide To Programmable Videogames

# electronic GAMES

Videogames · Computer Games · Stand-Alone Games · Arcades

DD04114

DECEMBER, 1982 • \$2.95

EG's Second  
Annual  
GIFT GUIDE  
FOR GAMERS

Is Colecovision The  
Next Great System?

You Can Be A  
Game Designer

See the  
System in the  
Suitcase

THE  
ULTIMATE  
GAMING  
GIFT







For Your Atari\* Video Game System



**SPACE ATTACK™**  
VIDEO GAME CARTRIDGE

For Your Atari\* Video Game System

**SPACE ATTACK™**  
VIDEO GAME CARTRIDGE

**FOOTBALL™**  
VIDEO GAME CARTRIDGE

For Your Atari\* Video Game System

**FOOTBALL™**  
VIDEO GAME CARTRIDGE

**LOCK 'N' CHASE™**  
VIDEO GAME CARTRIDGE

**LOCK 'N' CHASE™**  
VIDEO GAME CARTRIDGE

**LOCK 'N' CHASE™**  
VIDEO GAME CARTRIDGE

**BASEBALL™**  
VIDEO GAME CARTRIDGE

**BASEBALL™**  
VIDEO GAME CARTRIDGE

**ASTROBLAST™**  
VIDEO GAME CARTRIDGE

**ASTROBLAST™**

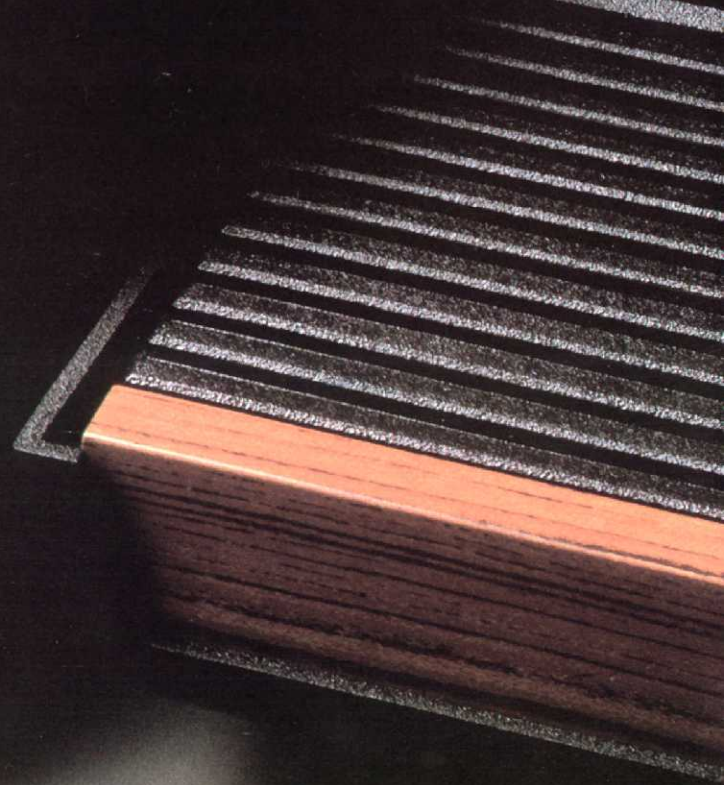



# DDA EWN ELIF OT IRATA CSV TIWH M NETWORK MEHO DIVOE MEGAS.

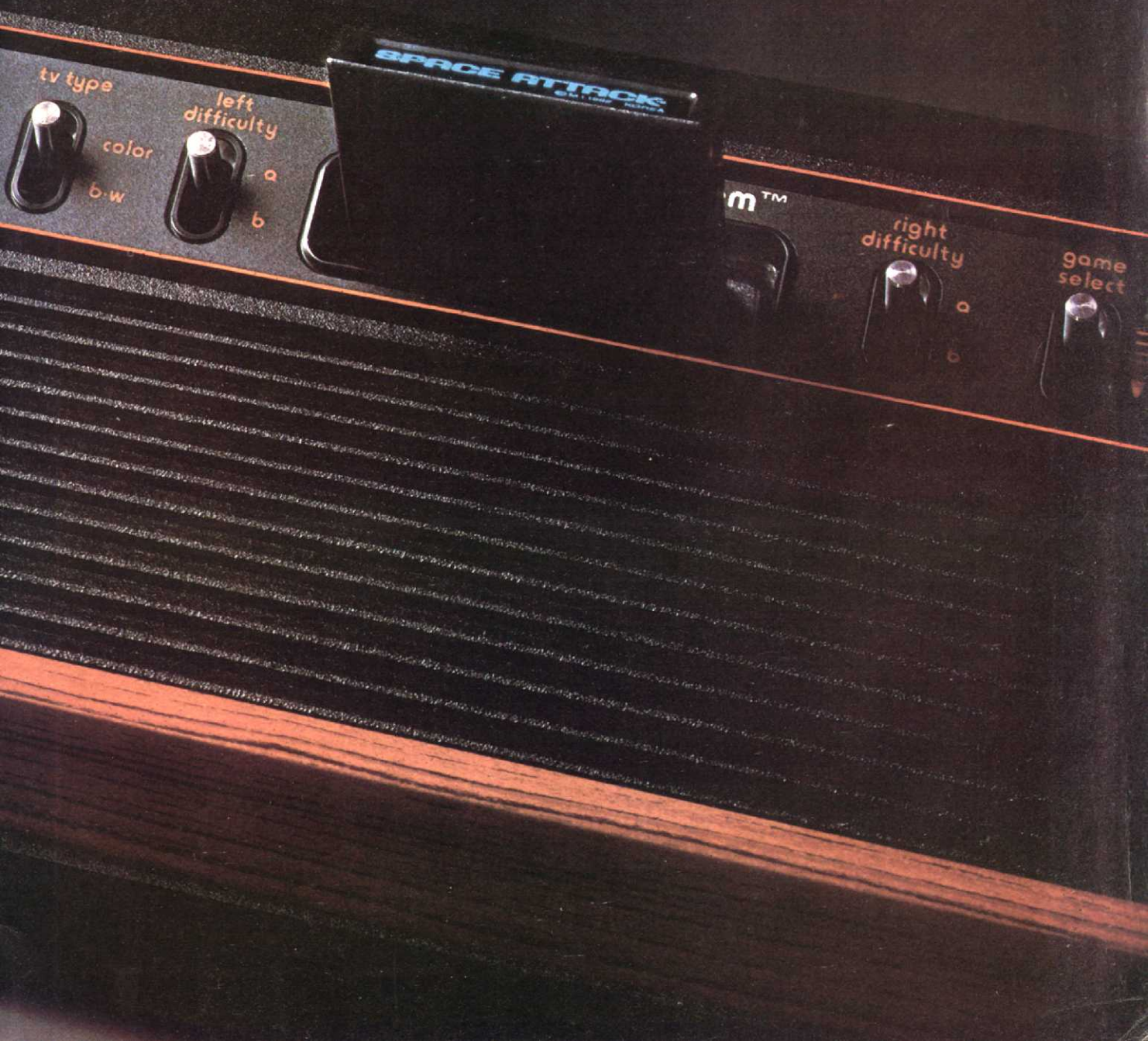



1. ETOMRES
2. OTERSUKIT
3. OSPC NAD BERSOBR
4. WHOOTNUDC
5. DARNIVES

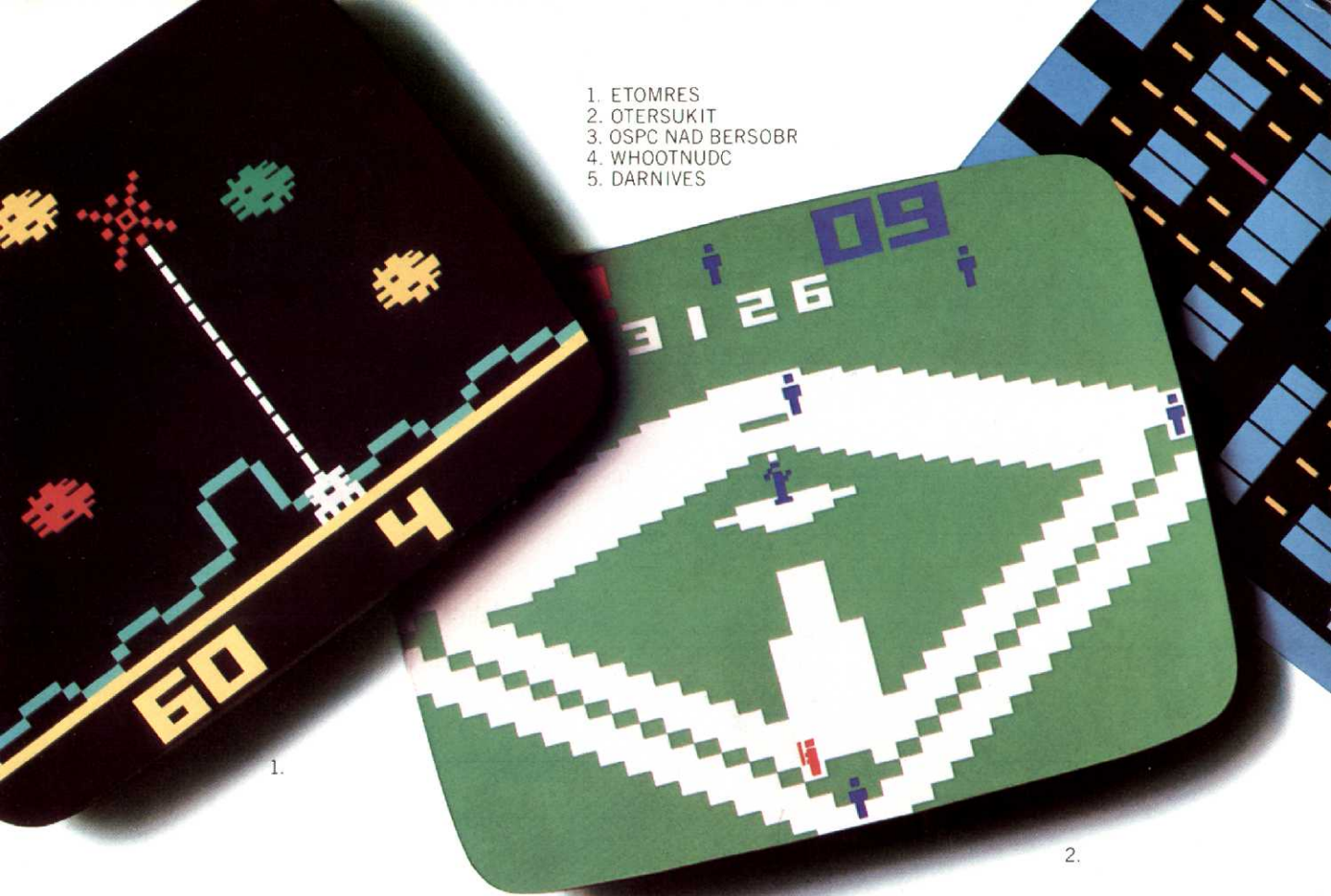

# UNSCRAMBLE THE M NETWORK VIDEO GAME WORD JUMBLE. FOR

If you can figure out what the word jumble above the Atari® VCS unit says, we don't have to say much more.

But we will say that with M Network™ video games, Atari® VCS owners can now experience new and realistic graphics with games like Super Challenge™ Baseball. Challenging gameplay with Astroblast™. And exciting sound effects with Lock 'N' Chase™.\*

Once you've got the headline figured out, take a look at the scrambled words above the video screens. (Up there on the left, that is.)

Unscramble them and match the appropriate word or words to the games on the video screens.

HEADLINE \_\_\_\_\_ M NETWORK WORD JUMBLE. (PUT ANSWERS HERE.)

1. \_\_\_\_\_ 2. \_\_\_\_\_

3. \_\_\_\_\_ 4. \_\_\_\_\_

5. \_\_\_\_\_

NAME \_\_\_\_\_

ADDRESS \_\_\_\_\_

CITY \_\_\_\_\_

STATE \_\_\_\_\_ ZIP \_\_\_\_\_

(Please print clearly)

Mail your entry to:  
 M Network Video Game Word Jumble  
 P.O. Box 4010  
 Burlingame, California 94010

of correct and eligible entries received  
 All entries must be postmarked by 12/31/82  
 Drawing will be held on 1/31/83.  
 Winners will be notified by  
 mail not later than 2/15/83.  
 Mattel Electronics will not  
 be responsible for lost, late  
 or misdirected mail.



#### CONTEST RULES

1. Prize structure
    - 1 Grand Prize: 1 full set of M Network™ Atari® VCS compatible game cartridges.
    - 5 First Place Prizes: 5 M Network game cartridges each.
    - 50 Second Place Prizes: 1 M Network game cartridge each.
- Game cartridges for both first and second prize winners will be determined by availability at the time of awarding prizes.
- 1,000 Runners-up: A \$2.50 check-coupon good towards the purchase of available M Network game cartridges.

\*Lock 'N' Chase is a trademark of Data East, Inc. Used under license.  
 Atari® is a trademark of Atari, Inc.





# M NETWORK™ VIDEO FUN AND GAMES.

Then complete the coupon to the left to try and win the grand prize of a complete set of M Network cartridges. Five first prizes of five M Network cartridges. Fifty second prizes of one M Network cartridge. And 1,000 \$2.50 check coupons good towards the purchase of any one M Network cartridge.

Winners will be determined by a random drawing from only those entries with all the correct answers.

Here's the perfect opportunity to discover which home video games offer new challenge and excitement. And which are just playing at it.

Because M Network video game cartridges cut through the video game jumble.

Each cartridge sold separately.

- 1. All prizes (1056) will be awarded. No substitutions of prizes will be permitted.
- 2. Eligibility is determined by correctness and completeness of each entry. Contestants may enter as often as they wish, but each entry must be submitted in a separate envelope. Entry form may not be reproduced by any method. No purchase is required. Only one prize per person, household, or organization.
- 3. Any and all taxes are the sole responsibility of the winner. Contest void in Florida, Wisconsin and wherever otherwise prohibited, taxed or restricted.
- 4. Employees, dealers, distributors, advertising and merchandising agencies of Mattel, Inc., or their families are not eligible for entry.



FROM MATTEL ELECTRONICS®



# electronic GAMES

**Editor**  
Arnie Katz

**Executive Editor**  
Bill Kunkel

**Senior Editor**  
Joyce Worley

**Technical Director**  
Henry B. Cohen

**Strategy Editor**  
Frank Tetro Jr.

**West Coast Editor**  
Les Paul Robley

**Associate Editors**  
Bill Heineman  
David Lustig

**Contributing Editors**  
C. Ross Chamberlain  
Steve Davidson  
Leigh Goldstein  
Tom Hirschfeld  
Charlene Komar  
Will Richardson  
Roger Sharpe  
Captain Sticky  
Rick Teverbaugh

**Editorial Assistant**  
Lisa Honden

**Art Director**  
Ben Harvey

**Graphic Consultants**  
Creative Concepts

---

**Los Angeles  
National Advertising Director**  
Jim Bender  
6215 Rustling Oaks Drive  
Agoura, CA 91301  
(213) 873-3416

**New York  
Advertising Manager**  
Ann Martino  
235 Park Avenue South  
New York, NY 10003  
(212) 777-0800

**Chicago  
Advertising Representative**  
Milton Gerber  
2607 North Prindle  
Arlington Heights, IL 60004  
(312) 398-3032

**Coordinator**  
Kathleen Carter

---

**Publisher**  
Jay Rosenfield

**Co-Publisher**  
Arnie Katz

**Editorial Director**  
Bruce Apar

**Executive Advertising Director**  
Bruce Mishkin

**Production Manager**  
Laurie Ann Devereaux

**Circulation Director**  
William D. Smith

---

**Illustrators**  
Brez  
Frank Emmi  
Arron Epstein  
David Febland  
Arthur George  
Beirne Lowry  
Neil McPheeters

**Cover Illustration**  
Mark & Stephanie Gerber

SWITCH ON! .....	6	INSIDE GAMING .....	62
ELECTRONIC GAMES HOTLINE .....	8	INSERT COIN HERE .....	64
READERS REPLAY .....	16	ARCANE AMERICA .....	68

## Feature

### COLECOVISION: NEXT STEP IN VIDEOGAMES?



Coleco promised its "third wave" system would play like a dream and look like a coin-op. Can it cash this check?

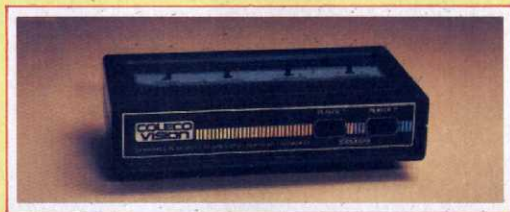

GIFT GUIDE FOR GAMERS ...	24	THE ULTIMATE GAMING GIFT .....	94
YOU CAN BECOME A GAME DESIGNER .....	34	STAND-ALONE SCENE .....	98
PROGRAMMABLE PARADE ...	38	COIN-OP CLASSROOM ....	106
<b>Special Section</b>		MINI-ARCADE GALLERY ...	112
PLAYERS GUIDE TO PROGRAMMABLE VIDEOGAME SYSTEMS	49	Q&A .....	118
EG's magazine-within-a-magazine presents a comprehensive probe of the eight major systems.		PINBALL PALACE .....	122
		READER POLL .....	137
		COMING NEXT ISSUE .....	138

**ELECTRONIC GAMES** (ISSN 0730-6687) is published monthly by Reese Publishing Company, Inc., 235 Park Avenue South, New York, NY 10003. Application to mail at second-class postage rates pending at NY, NY and additional mailing office. © 1982 by Reese Publishing Company, Inc. All rights reserved. © under Universal, International and Pan American Copyright conventions. Reproduction of the editorial or pictorial content in any manner is prohibited. Single copy price, \$2.95. Subscription rates: one year (12 issues) \$28; two years (24 issues) \$48; Canada, one year \$32, foreign, Air Mail only, one year \$64. Address subscription orders and correspondence to **ELECTRONIC GAMES**, P.O. Box 1128, Dover, NJ 07801. Change of address takes 60 days to process; send old address label, new address and zip code. All material listed in this magazine is subject to manufacturer's change without notice, and publisher assumes no responsibility for such changes. Membership in the Audit Bureau of Circulations Applied For. Printed in the U.S.A.

POSTMASTER: Send form 3579 to **ELECTRONIC GAMES**, P.O. Box 1128, Dover, NJ 07801.



# HOW TO BEAT ANY VIDEO GAME SINGLE-HANDED.

## WITH THE QUICK-SHOT™ JOYSTICK CONTROLLER

MODEL 318-101

Beating any video game is easy, but beating it single handed takes a lot more. It takes a good joystick that is responsive and comfortable. Now with Spectravision's new Quick-Shot™ Joystick Controller, you can do it all single-handed; control and fire at the same time.

One look at the handle and you know you'll have a better grip on your game. It's contour design fits comfortably around your palm. You can play for hours without developing a case of sore thumb. The firepower button on top of the handle gives you that extra margin of

### THE WINNING EDGE.



CONTOUR HANDLE AND RAPID FIRE BUTTON



OPTIONAL LEFT HAND FIRE BUTTON



UNIVERSAL JACK & LONG CORD



REMOVABLE SURE FOOT SUCTION CUPS

### FOR USE ON THE

- ATARI VCS SYSTEM
- SEARS VIDEO ARCADE
- VIC-20 COMPUTER
- ATARI 400 & 800 COMPUTER SYSTEMS

speed. (We didn't call it Quick-Shot for nothing.) You also have the option to use the left hand fire button simultaneously.

The four removable suction cups hold the entire joystick firmly on any surface. It also comes with a long cord.

With all those superior features in one joystick, you know you got yourself a winning combination. And when it comes to beating video games, one hand is all you need!

Get the Quick-Shot™ now, you'll be that much ahead. After all, winning is what every game is all about.

## QuickShot™

BY **SPECTRAVISION™**

39 W. 37th Street, New York, N.Y. 10018



# SWITCH ON

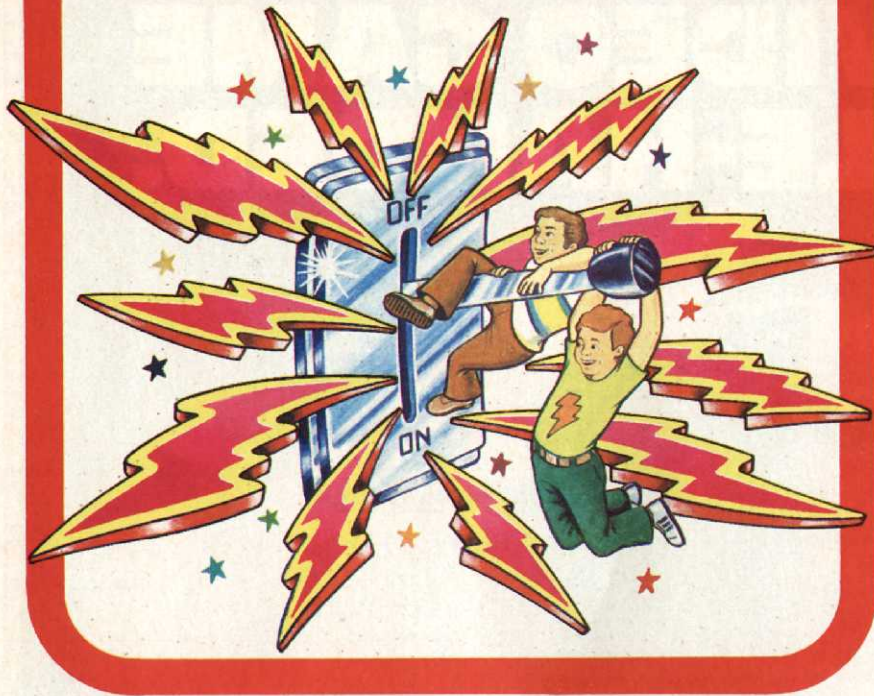

## Inside the Arkies

By ARNIE KATZ

Not everyone gets to romp through the weeks between Thanksgiving and New Years without having to think of anything more serious than the probable future availability of mistletoe. Here and there across the land, editors of **Electronic Games** are studying the eligible candidates and making their final recommendations for the Fourth Annual Arcade Awards to salute design excellence in both the home and commercial arcade arenas.

Let's not kid ourselves, it's really kind of fun to sort through the huge pile of cartridges that has accumulated this year and pick out winners of these coveted prizes. Yet if the Arcade Awards — Arkies for short — didn't have an important, special meaning to the hobby of electronic gaming, the folks here at **EG** wouldn't be so quick to exchange their turkey for **Turbo** or skip the Christmas goose to play a few extra test rounds of **Galaga**.

When Reese Publishing Company, which brings you *Arcade Express* and *Video* as well as **Electronic Games**, decided to sponsor the Arkies four years ago, it was with a definite purpose in view. Even back in 1978 when **Space Invaders** was still new, and a few

pioneering gamers were telling their friends and neighbors about their just-purchased programmable videogame machines, the brain trust at 235 Park Avenue South could see the entertainment revolution coming. They knew that the pressures of the free marketplace might encourage some manufacturers to make quantity a higher priority than quality.

The Arcade Awards, then, are intended to make sure that the emphasis in our fast-growing hobby stays on good games, not just a lot of them. We need this type of qualitative yardstick more than ever these days. Why, more videogame cartridges came out last month than in all of 1978! It's getting easier and easier for a really good game to get lost in a tide of ordinary ones. By calling attention to our field's outstanding software achievements, the Arcade Awards throw the spotlight of public notice on these worthy games that might otherwise get overlooked. In short, the Arkies are a method for honoring those designers who are enriching our gaming experience with innovative graphics, sounds and play-action, while giving those who are content to just copy the successes of others the cold shoulder.

And so it is with great pleasure that I announce a major expansion of the Arcade Awards this year. Where once

we gave fewer than a dozen plaques, a total of 26 Arcade Awards in four major categories — videogames, computer games, coin-ops and stand-alone games—will be presented.

Not only that, but the Arcade Awards Committee has also established a second tier of awards for the many superb games which simply can't be given Arkies due to the incredibly fierce competition. Starting this year, we'll be giving several Certificates of Merit in each Arcade Award classification. And, of course, we'll also provide a list of Honorable Mentions, games which are good, but not quite good enough for an Arkie or Certificate of Merit.

The winners? Ah, but that would be telling. Hold onto your curiosity for 30 days and the January **Electronic Games** will be here with a complete report on the 1983 Arcade Awards. Meanwhile, why not look over the list of categories and make your own selections. Then you can have the fun of seeing how close you've come to the opinions of our judges when we unveil the winners next month.

Until then, the entire staff of **Electronic Games** and Reese Publishing wish you the happiest and healthiest possible holiday season! ☺



## The Fourth Annual Arcade Awards

### Videogame Division:

- Videogame of the Year
- Best Science Fiction/Fantasy Videogame
- Most Innovative Videogame
- Best Solitaire Videogame
- Best Multi-Playing Videogame
- Best Videogame Audio/Visual Effects
- Best Arcade-to-Home Videogame Translation
- Best Action Videogame
- Best Videogame Adventure
- Best Sports Videogame

### Computer Game Division:

- Computer Game of the Year
- Best Computer Adventure
- Best Science Fiction/Fantasy Computer Games
- Best Action Computer Game
- Best Computer Game Audio/Visual Effects
- Best Sports Computer Game
- Best Solitaire Computer Game
- Most Innovative Computer Game

### Coin-op Division:

- Arcade Game of the Year
- Best Science Fiction/Fantasy Arcade Game
- Best Arcade Audio/Visual Effects
- Best Action Arcade Game
- Most Innovative Arcade Game

### Stand-Alone Division:

- Stand-Alone Game of the Year
- Best Electronic Boardgame
- Best Mini-Arcade Cartridge Game



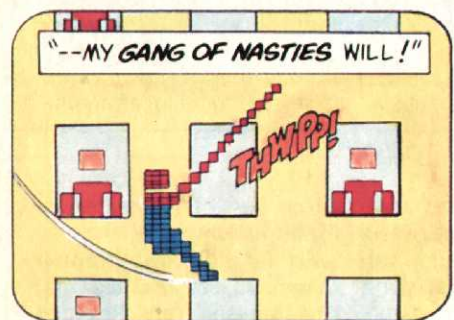
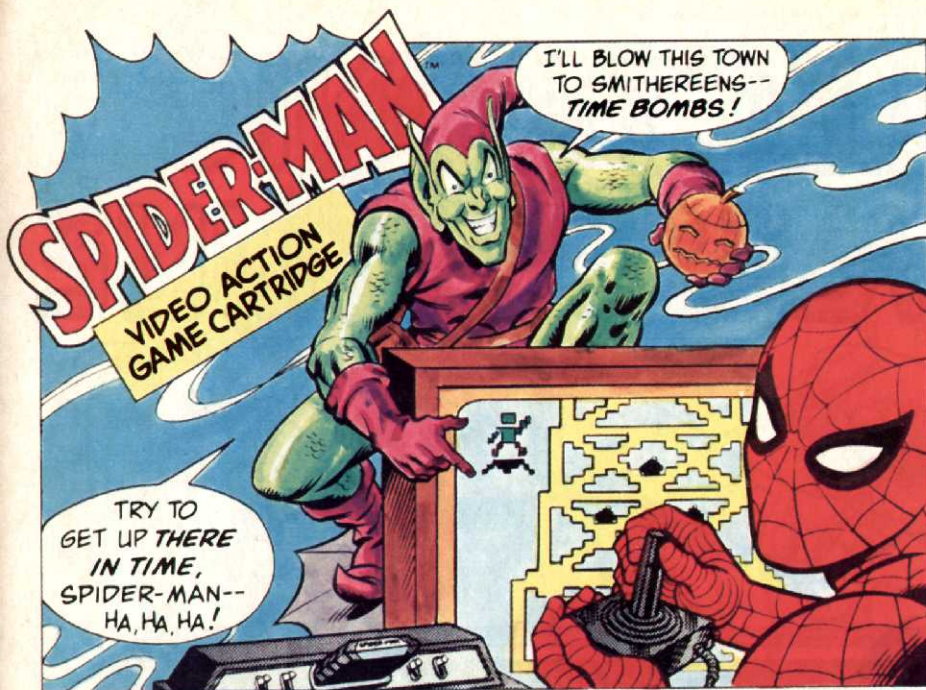

The Goblin's time bombs are ticking away. And his Super Bombs sit fiendishly up on High Voltage Towers. The city is on its knees.

Only Spider-Man's spidey powers can get us out of this! Thwipp! He shoots his web and swings up the buildings to reach the bombs.

Thwipp! He shoots again, escaping the Goblin on his web-cutting jet glider.

But watch out! Goblin and his warped gang of criminals have more sneaky ways to cut your web and plunge you to the streets below.

Can you get Spider-Man to the bombs in time? Your web fluid is getting lower. And time is ticking away. . . .



For your Atari Video Computer System™ and Sears Video Arcade™

**PARKER BROTHERS**

Sears Video Arcade™ is a trademark of Sears, Roebuck and Co. and Atari Video Computer System™ are trademarks of Atari, Inc. SPIDER-MAN and THE GREEN GOBLIN™ TM and Copyright © 1982 by the Marvel Comics Group, a division of Cadence Industries Corp. © 1982 Parker Brothers, Beverly, MA 01915



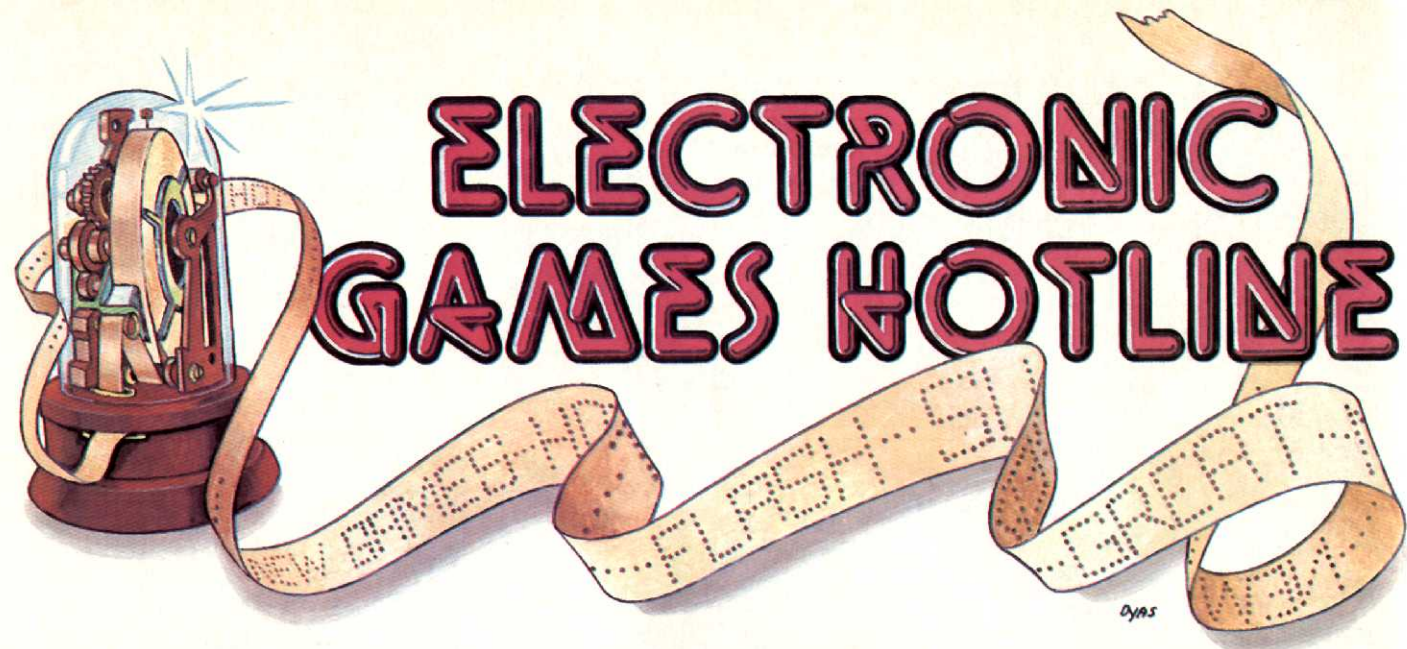

# ELECTRONIC GAMES HOTLINE

## MILTON BRADLEY ACQUIRES G.C.E.

Milton Bradley recently announced its acquisition of all business assets of General Consumer Electronics (GCE) for an undisclosed amount of money. GCE, founded in 1980, will be operated as a wholly-owned subsidiary still retaining its original name.

GCE has attracted lots of industry-wide attention of late with its introduction of Vectrex, the self-contained home



videogame system that utilizes Vectrascan technology. Some gamers may be more familiar with GCE's line of watches and calculators, which incorporate game-playing action to relieve the drabness of everyday time-telling or number crunching.

Future plans for Vectrex include its introduction in seven of the country's largest markets this winter, so keep your radars scanned!

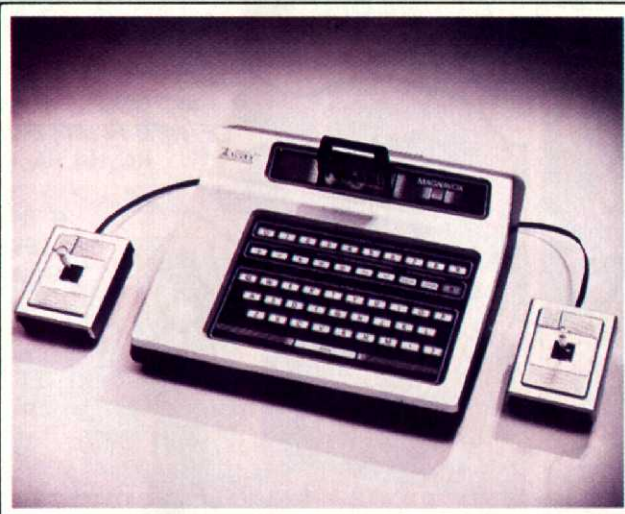

The Odyssey<sup>2</sup> with internally-connected joysticks

## O<sup>2</sup> ADDS MORE JOY TO STICK

Attention all budget-conscious home arcaders: You'll be happy to hear that Magnavox has decided to give gamers a break by dropping its price for the O<sup>2</sup>'s joystick controller to a mere \$20. Of course, owners of newer versions of the console will have to pry into their units to install such a replacement stick.

At the same time, Magnavox revealed plans to market the O<sup>2</sup> through Sears and Ward Stores. The game will be sold under its own name, so holiday shoppers won't have to search too far for a bargain.

## VIDEOGAMES GO TO THE MOVIES

We're all accustomed to the commercials which break into regularly scheduled TV shows, but now movie theaters offer no escape, either.

It's really not as bad as it sounds, though, because some of the paid messages are actually vide-o.k.! Activision, Mattel and Atari have all bought cinema commercial packages from Screenvision,

which has 1,600 theater affiliates nationwide.

So far, ads for **Chopper Command**, **Star Master**, **Tron**, **Dig-Dug** and **Yars' Revenge** have hit and even more are expected down the road.

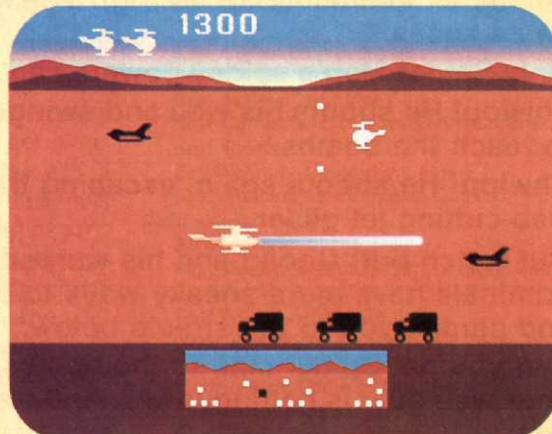
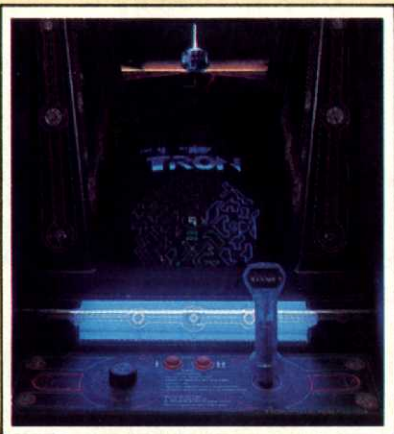



# AMIDAR™

VIDEO GAME CARTRIDGE



## BRING HOME THE GAME THAT'S WAY AHEAD OF THE PACK.

Tired of seeing dots before your eyes? Ready for a video game with some personality? Then make the move to the wacky world of AMIDAR.™

First you're a gorilla trying to draw boxes inside a maze. It's not easy though, because



you're being chased by savage sentries every step of the way. Just like in the arcade game.

Now you're a paint roller trying to paint squares while being pursued by persistent pigs. No one ever said it was going to be easy. AMIDAR. One of a kind in a dot-eat-dot world.

 **PARKER BROTHERS**

AMIDAR game graphics © 1982 Konami Industry Co., Ltd. AMIDAR is a trademark of Konami Industry Co., Ltd. and used by Parker Brothers under authorization. © 1982 Parker Brothers, Beverly, MA 01915.



## ATARI BEGINS GREATEST ADVENTURE

The company that sometimes prides itself on putting as many games as possible on a single cartridge is now ready to take the opposite tack with

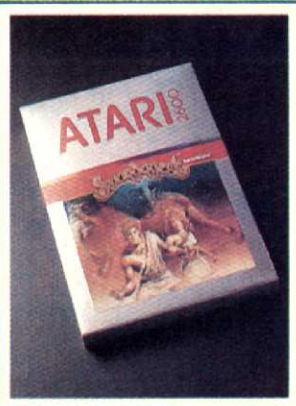

**Swordquest**, its innovative videogame adventure. This time, it'll take four separate cartridges to contain the elements that combine to present this quest from start to finish.

Atari plans to kick things off

with the **Earthworld** cartridge. This will be followed, at regular intervals, by publication of **Fireworld**, **Waterworld**, and **Airworld** over the next year. Each cartridge is complete in itself, but it is necessary to solve the mystery of one before going onto the next. Designers will be hiding things in the cartridges in a fashion similar to the "easter eggs" in earlier games, but this time your reward will be something a bit meatier than just some programmer's initials.

Each cartridge will be the subject of a special prize contest. The winner of the **Earthworld** competition, for example, can take home a bejeweled talisman worth \$25,000. There'll be a bauble of similar worth for the top player of each segment of the total adventure. The winners of each will then come together for a special play-off in which the winner will become the proud owner of a \$50,000 jewel-encrusted sword, suitable for keeping trolls and orcs away from your door.

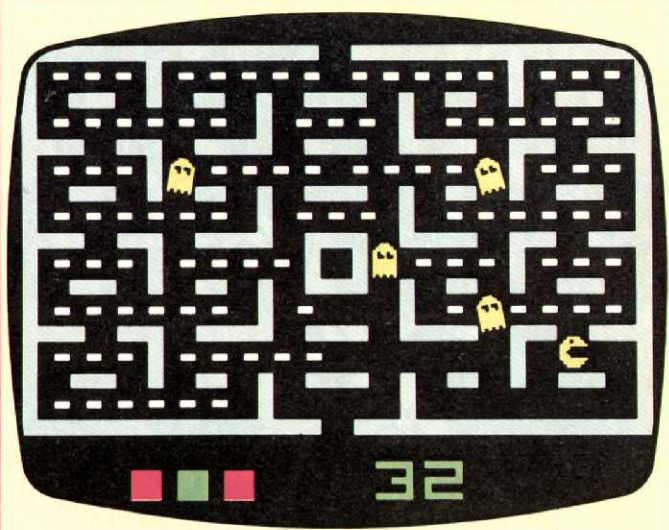

## SATURDAY MORNIN' GOBBLERS

Forget it NBC and CBS—you had your chance! Now, everyone can catch their fave video vagabond strutting his stuff on ABC every Saturday morning. The series' cast features Pac-Man, Ms. Pac and Pac-Baby, all residing in—you guessed it—Pac-land!

Their utopia is disrupted by

Mezmaron, a meanie who craves all existing power pellets in the forest. Every meanie has his hatchet man and Mezmaron, accordingly, won't carry the banner of evil alone. Assisting him in his dastardly deeds are ghost monsters Inky, Blinky and Clyde, along with a girl-ghost named Sue.



## HUNTING A HERO

Activision and the producers of ABC TV's hit series, "The Greatest American Hero", Robert Culp and William Katt, are co-sponsoring a nationwide contest to locate "The Greatest American Videogame Hero".

Contestants must play **Star Master** on its most difficult setting and the highest scorers

in six different age groups will fly to Hollywood for three days. There they'll take part in a private filming with the stars of "The Greatest American Hero", Robert Culp and William Katt.

Prizes include a copy of the film and a video cassette recorder to help them remember the star-filled day. T-shirts will go to the top 200 scorers in each age category.



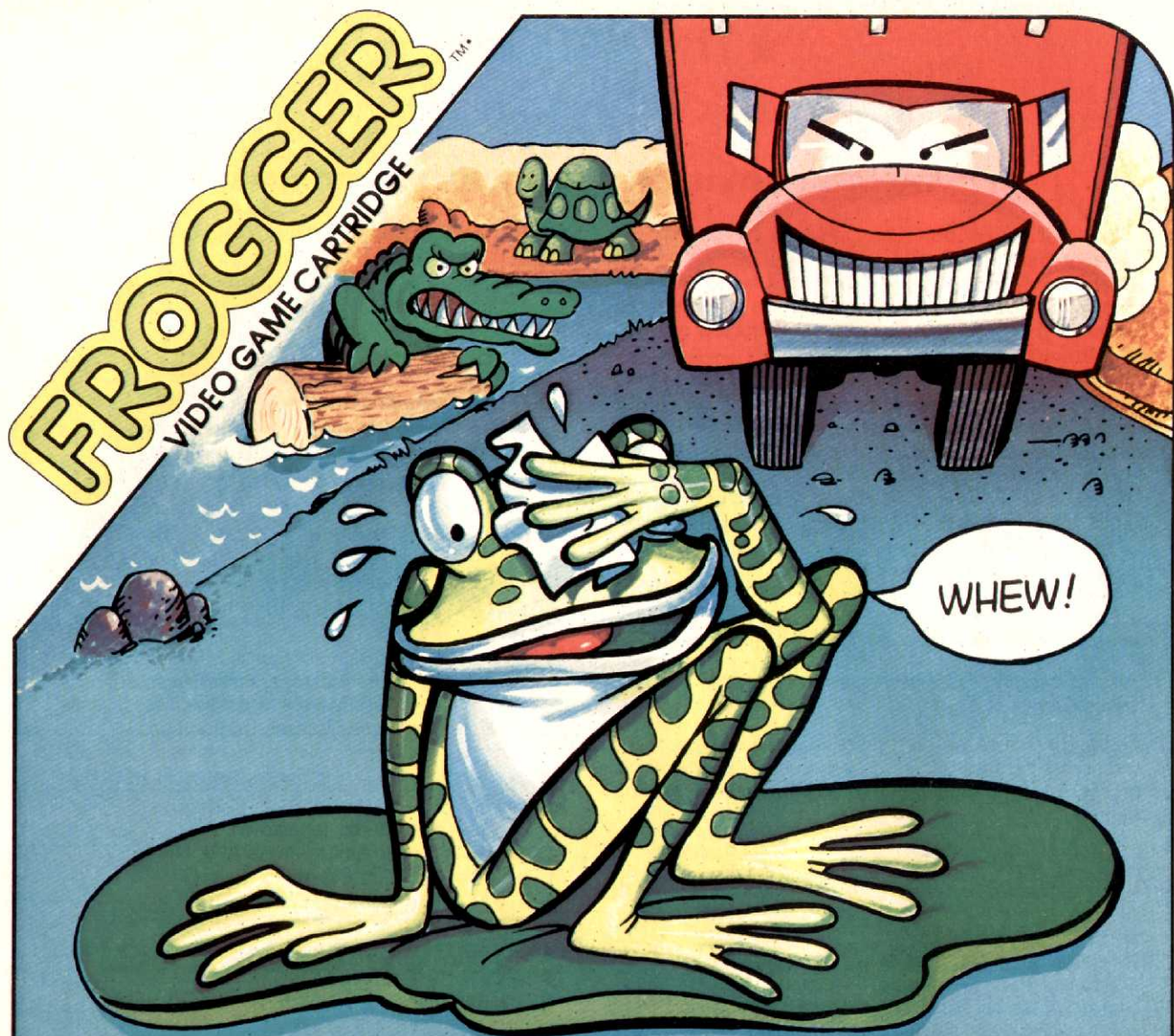

## WE HOPPED FROGGER™ OUT OF THE ARCADE. NOW CAN YOU HOP HIM HOME?

Frogger has just jumped out of the arcades and into your home. Sights, sounds, and all. Do you have the skill to get him to his home?

Frogger's first challenge is to cross a highway where reckless hot rods hurtle by, and huge trucks go thundering in his path. Every safe jump in this maze of motor and metal is a crucial step home.

Beyond is the raging river where the safety of a slippery log or diving turtle is all Frogger can count on to stay afloat.

Frogger's last leap to his lily pad home must be perfect, or it's back to the road to try again. Good luck. Frogger's counting on you.

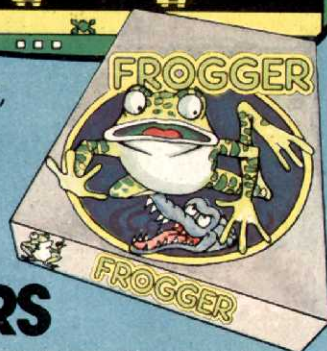
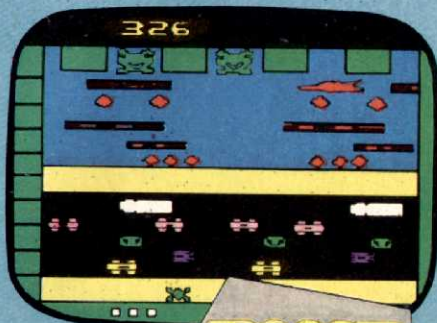

For your Atari Video Computer System™ and the Sears Video Arcade.™

 **PARKER BROTHERS**

FROGGER game graphics © 1982 Sega Enterprises, Inc. FROGGER is a trademark of Sega Enterprises Inc. Sears Video Arcade™ is a trademark of Sears Roebuck & Co. Atari® and Atari Video Computer System™ are trademarks of Atari, Inc.



## ★ THE NATIONAL ★

# ARCADE SCOREBOARD

### THE BEST SCORES FOR POPULAR VIDEOGAMES

Photos of readers' best scores are really pouring into the offices of **Electronic Games**, and the competition among the land's arcade aces is even keener than expected. There are plenty of top players out there, and the rankings listed here show that they're hitting the joystick hot and heavy in a bid for national recognition.

The scores tabulated here reflect the first group of games which the editors of **EG** selected to kick off this continuing compilation of home videogaming records. We'll be adding more games each month, a few at a time, until we're covering most of what's hot!

To have your gaming achievements recognized in the National Arcade Scoreboard, all you've got to do is follow a few simple rules:

1. Every score must be accompanied by a photograph of the TV screen showing the score. These photos do not have to be of publishable quality, just readable by our judges.
2. All photographs received become the property of **Electronic Games** and none can be returned.
3. Be sure to include your complete name and address. (We will print only the name and city in the magazine, but we may want to contact high scorers for helpful gaming hints.)

Games currently eligible for the National Arcade Scoreboard are:

- ★ **UFO** (Odyssey)
- ★ **Asteroids** (Atari VCS) — Game #6
- ★ **Grand Prix** (Activision) — Game #4
- ★ **USAC Auto Racing** (Mattel) — Course #1
- ★ **Galactic Invasion** (Astrocade) — Difficulty #1
- ★ **Spacechase** (Apollo) — Game #1
- ★ **Defender** (Atari VCS) — Game #1

★ **The Incredible Wizard** (Astrocade)  
(One player, easy difficulty)

★ **Space Hawk** (Mattel) — Game #1  
(Auto-fire if desired)

★ **Pac-Man** (Atari VCS) — Game #1

### THE HONOR ROLL

#### UFO/Odyssey/Odyssey<sup>2</sup>/Game #1

1. **1,636** — Lee Raymond, no address given
2. **1,575** — Jim Peterson, Farmington Hills, MI
3. **1,461** — Marlon Burns, Chicago, IL

#### Asteroids/Atari/Atari VCS/Game #6

1. **199,930** — Edward Semrad, Waukesha, WI
2. **129,460** — Robert Prindle, Erie, PA
3. **128,460** — Scott Allen, Huron, OH

#### Grand Prix/Activision/Atari VCS/Course #4

1. **1:35:39** — Mike Ratledge, Folly Beach, SC
2. **1:42:12** — Mark Martell, Brooklyn, NY
3. **1:43:93** — Darrin Yamamoto, Bonita, CA

#### USAC Auto Racing/Mattel/Intellivision Course #1

1. **2:58** — John Bunk, Johnstown, PA
2. **2:59** — Donald Smith, Pease AFB, NH
3. **3:02** — Don Gaze, Ontario, Canada
4. **3:02** — Ken Debelak, Glendale, AZ

#### Galactic Invasion/Astrocade/Astrocade Difficulty #1

1. **99,999** — Steve Sabolich, no address given

#### Spacechase/Apollo/Atari VCS/Game #1

1. **42,600** — John Opiela, Philadelphia, PA

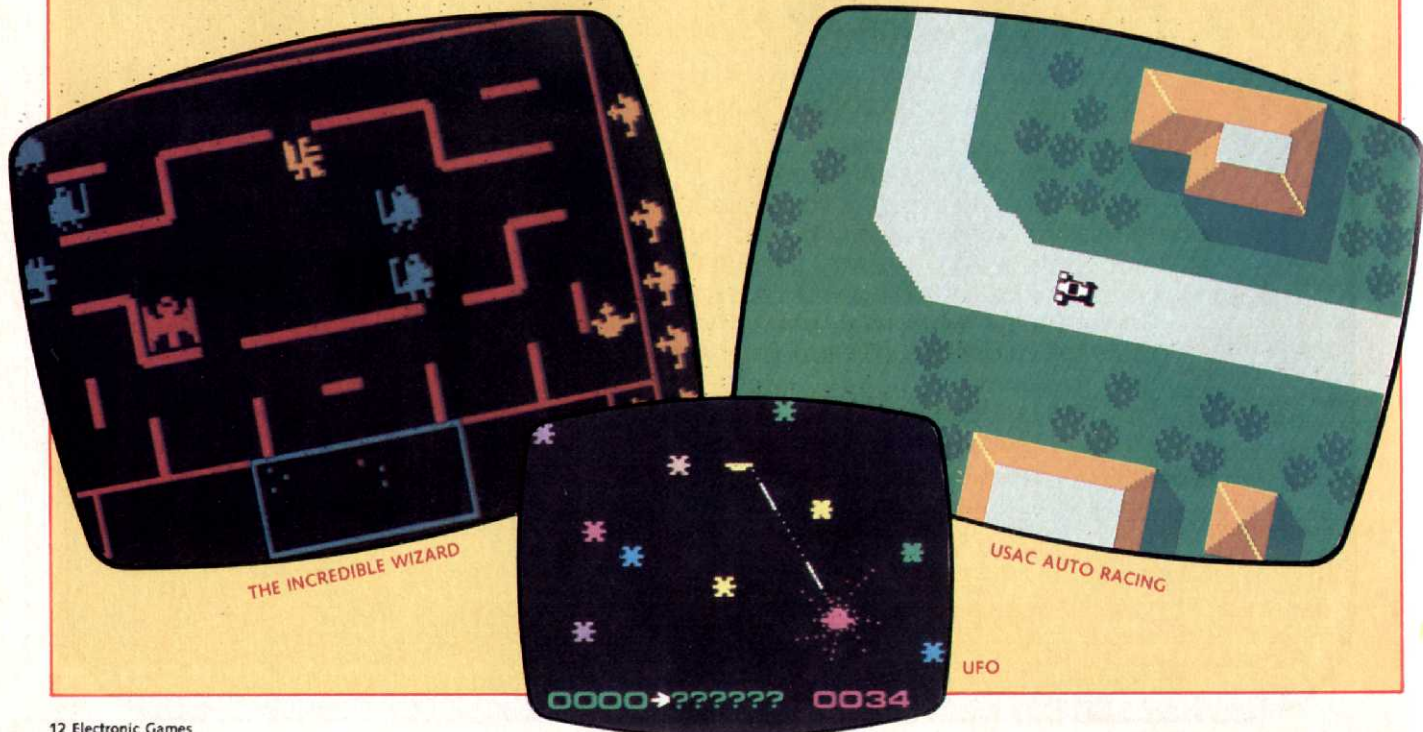



# STAR WARS™

THE EMPIRE STRIKES BACK™  
VIDEO GAME CARTRIDGE



## BRING THE BATTLE HOME!

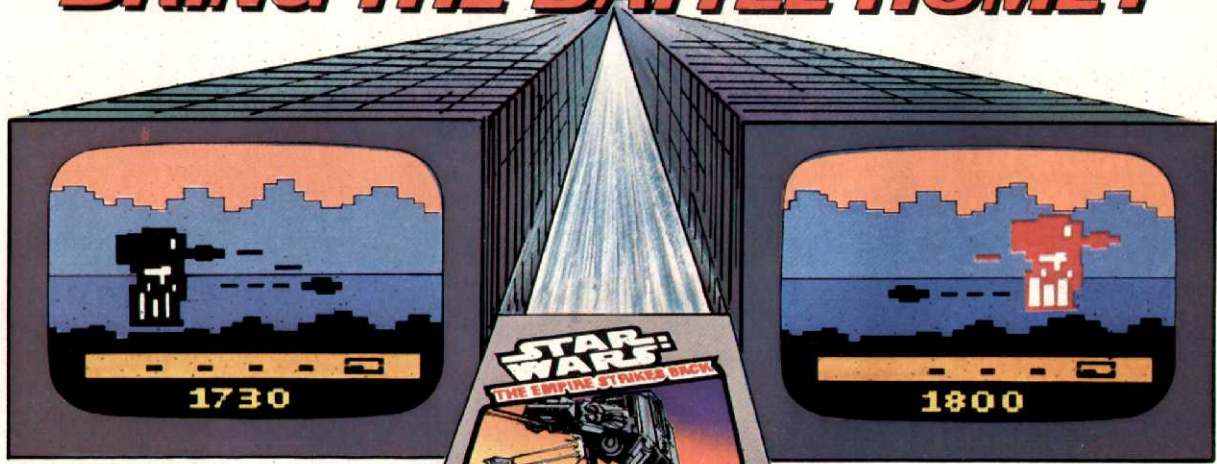

The Imperial Walkers are moving toward the Rebel base on the Ice Planet Hoth.\*™ Can you destroy them before they blow up the power generators? Quick, into your Snowspeeders!™ Launch your attack! You can stop the Walkers

with a perfect shot at the flashing bomb hatch. Take careful aim! Fire! KAPOW! But more Walkers are coming. They attack with deadly missiles and smart bombs. Shoot them down or be destroyed! May The Force Be With You!™

For your Atari Video Computer System™ and Sears Video Arcade.™

**PARKER BROTHERS**

© Lucasfilm Ltd. (LFL) 1982 \*\*\* Trademarks owned by Lucasfilm Ltd. (LFL) and used by Parker Brothers under authorization. Sears Video Arcade™ is a trademark of Sears Roebuck and Co. Atari® and Atari Video Computer System™ are trademarks of Atari, Inc.



# THE NATIONAL VANITY BOARD

## Today's Top Coin-op Scores

Electronic Games is proud to announce the creation of the National Vanity Board to identify and honor the nation's arcade aces. Just as the National Home Arcade (set to debut next month) salutes the achievements of the lords and ladies of livingroom gaming, the National Vanity Board will monitor the triumphs of the kings and queens of the coin-op videogaming world.

EG will update the listings each month based on information provided by game manufacturers, arcade operators and, most importantly, our hundreds of thousands of readers. If you or one of your buddies rewrites the record book for the most popular commercial arcade machines, getting the proper recognition for the new champ is as easy as following these three steps:

1. Set the record.
2. Show the arcade manager on duty your record score and have him (or her) sign the proper portion of the report form—copies or facsimiles are fine.
3. Mail your score report to: Electronic Games, 235 Park Avenue South, Sixth Floor, New York, N.Y. 10003.

### Score Report Form

Name of Player (Please Print) \_\_\_\_\_

Player's Address \_\_\_\_\_

Name of Game \_\_\_\_\_

Score \_\_\_\_\_

Name of Arcade \_\_\_\_\_

Arcade Address \_\_\_\_\_

Arcade Operator's Signature \_\_\_\_\_

### Here Are the Arcaders to Beat!

#### Battlezone (Atari)

Larry Stonebrink  
Newberg, OR  
Record: 7,007,000

#### Missile Command (Atari)

Joe Fernandes  
Artesia, CA  
Record: 52,246,260

#### Centipede (Atari)

Rijanto Joesoef  
Los Angeles, CA  
Record: 4,421,232

#### Star Castle (Cinematronics)

Bob Mines, Jim Prucey  
Cortland, OH  
Record: 9,833,940

#### Crazy Climber (Taito)

Jim Wright  
Lake Orion, MI  
Record: 487,150

#### Defender (Williams)

Marvin Norton  
Safford, AZ  
Record: 49,367,750

#### Pac-Man (Midway)

David Marsden  
Santo, TX  
Record: 14,880,210

#### Ms. Pac-Man (Midway)

**Armor Attack (Cinematronics)**  
John Hooper  
Lakewood, CA  
Record: 319,670

#### Scramble (Stern)

Jason Itzler  
Cliffside Park, NJ  
Record: 8,410,500

CENTIPEDE



#### Phoenix (Centuri)

Orlando Funderburk  
Charlotte, NC  
Record: 466,462

#### Astro Blaster (Sega/Gremlin)

Bobby Hinds  
Laredo, TX  
Record: 72,850

#### Gorf (Midway)

John Chandler  
Hobbs, NM  
Record: 225,100

#### Dig-Dug (Atari)

Mark Hunt  
Seattle, WA  
Record: 2,360,000

#### Donkey Kong (Nintendo)

Steve Sanders  
Clinton, MO  
Record: 863,500

#### Frenzy (Stern)

Tracy Parish  
Millington, TN  
Record: 145,427

#### Frogger (Sega/Gremlin)

David McPhee  
Muncie, IN  
Record: 507,230

#### Galaga (Midway)

David Marcotte  
Seminole, FL  
Record: 4,314,000

#### Omega Race (Midway)

Rick Klin  
Lorvallis, MT  
Record: 1,215,200

#### Stargate (Williams)

Joe Startz  
Kenosha, WI  
Record: 20,449,975

#### Robotron (Williams)

Dennis Felland  
Madison, WI  
Record: 76,223,720

#### Tempest (Atari)

Eric Click  
Houston, TX  
Record: 1,311,290

#### Vanguard (Centuri)

Paul Baggett  
Mesquite, TX  
Record: 259,250

#### Wizard of Wor (Midway)

James Hussiere  
Poland Springs, ME  
Record: 150,900

#### Zaxxon (Sega/Gremlin)

Allen Rager  
Millington, TN  
Record: 772,500

#### Tron (Midway)

Pieter Kreyns  
Bethel Park, PA  
Record: 118,651

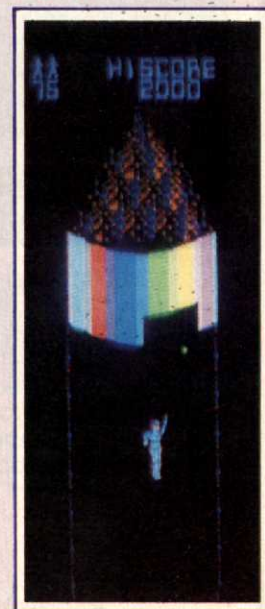

TRON



# WICO COMMAND CONTROL™



**Arcade challenge,  
accuracy,  
precision,  
speed,  
durability,  
quality,  
sensitivity  
and excitement.**

**Now yours,  
at home.**

Who else but WICO could make that claim? WICO is the world's largest designer and manufacturer of controls for the arcade.

**WICO Consumer Division • Niles, IL 60648**

WICO Command Control joysticks and trackballs work with Atari® and 8 other home video games and computers.

Atari® is a registered trademark of Warner Communications.

WICO® is a registered trademark of Wico Corporation. © 1982 Wico Corporation.





**PROGRAMMING POINTERS**

In your letter section in the September issue Chris Snyder wrote in asking about becoming a game designer. I've been a computer fanatic for about a year now and love to write software for the game-hungry software houses that are all around. It was very smart of you to tell Chris to get into assembly language, because that's about all the companies want.

Anyway, I thought you might like to include a list of companies that are buying programs from independents: Broderbund (Apple and Atari computers); Strategic Simulations (war and arcade games for Apple and Atari); software for all major computer systems); Big Five (arcade games for TRS-80, Apple, Atari); Advanced Operating Systems (all types for most major systems); Aardvark (TRS-80 Color Computer, OSI); Futurview (arcade, adventures for TRS-80); and Instant Software (all types for all systems).

Also, and this is especially for Chris, Atari has a regularly-running contest for various software categories with the reward of having Atari market your product, an Atari Star Award and, of course, some money.

Morgan Dunn  
Piscataway, NJ

*Ed: Thanks, Morgan. I'm sure this info will be of service to many of our creative readers. And check out this issue's piece on how to prepare for a career as a game designer.*

**MORE FROM INTELLIVISIONARIES**

I am now a reader of **Electronic**

Games and I must say that I really do enjoy your magazine. Unfortunately, I do have one bone to pick. The only thing is that in all the issues I've seen there hasn't been one bit of praise for the Mattel Intellivision, and the Atari VCS can do no wrong.

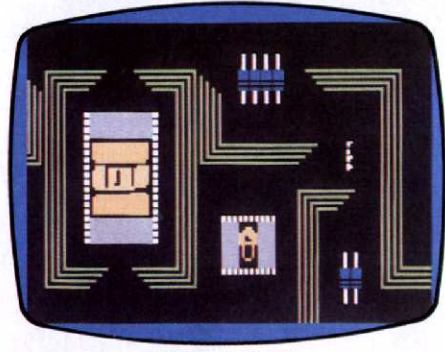

MAZE-A-TRON

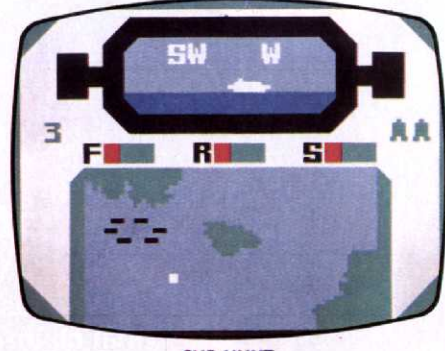

SUB HUNT

Despite the larger library offered by Atari, Mattel has some 40 cartridges available. I've played both systems and have found Intellivision superior to the VCS in graphics and sound.

Dale Albritton  
Summit, MS

I just received and read your Sep-

tember issue and I'm totally fed up with your obvious bias against Intellivision.

Each issue, you devote minimal lip service to Mattel's games. When you even bother to include an Intellivision game in "Strategy Session", it's always about an old game that few people are interested in any longer (eg., **Astrosmash**, September issue). People want to hear about **Space Hawk**, **Night Stalker**, **Sub Hunt** and **Reversi**.

George Kontos  
West Chester, OH

I was originally going to write asking why you didn't give equal space in your magazine for home videogames, but I see with the September issue that you have started to give equal time not only to home gaming in general, but also to the Intellivision, which is the system I'm most interested in. I expect even more coverage will be devoted to Mattel's game player since the announcements of compatible cartridges by Imagic, Coleco and Activision.

David Lowe  
Hamilton, Ontario

*Ed: Whew. Abe Lincoln once made a very cogent comment about fooling all of the people all of the time. Well, it's just as tough to please all of the gamers all of the time. In any case, another famous statesman once said: "Let's look at the record." A search through issues May through October reveals that "Strategy Session" dealt with four Atari VCS-produced games, three VCS-compatible cartridges, and five Intellivision contests. Also, though we would hardly refer to a game such as **Astrosmash** as "an old game that*  
*Continued on page 132*



# KING KONG™ TO JAWBREAKER.™ NEW TIGERVISION MAKES YOUR ATARI® COME ALIVE WITH EXCITEMENT.

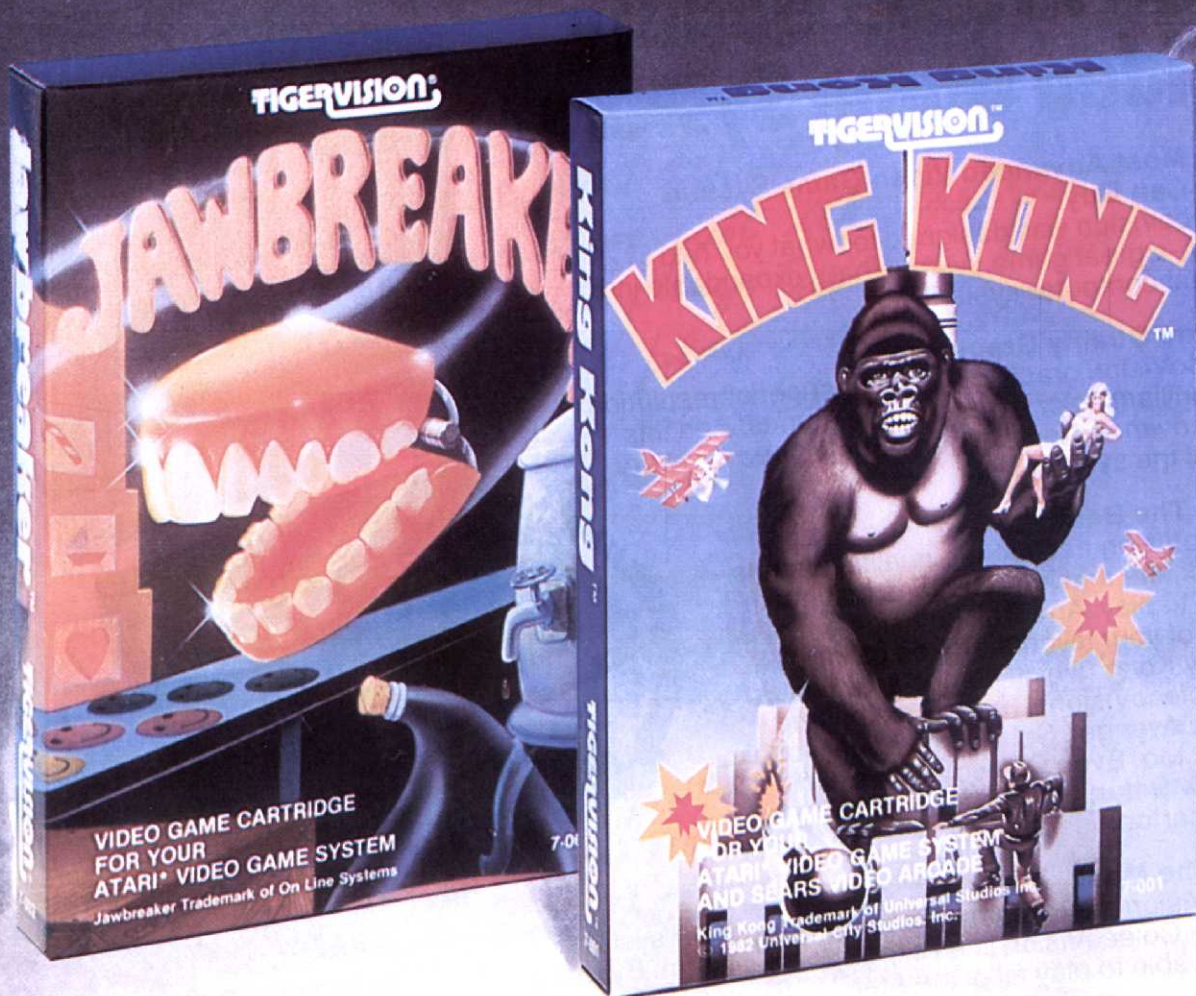

If you're at all into video games, the new captivating, action-filled games from TigerVision have got to make your most wanted list.

**King Kong™**—By climbing to the top of the Empire State Building, you attempt to rescue the beautiful lady from Kong's mighty clutches. But Kong will throw bombs at you every step of the way so the mission is as dangerous as it is thrilling.

**Jawbreaker™**—You're loose in a candy factory, getting your choppers on every bar of candy in sight. Clear the screen and a tooth brush will clean your teeth. Jawbreaker™. You're going to eat it up.

So there you have it. The fantastically exciting new video games for your Atari® set from TigerVision. Get your hands on the controls and you may never let go.

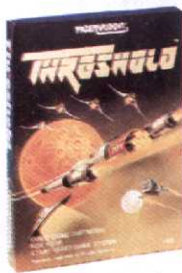
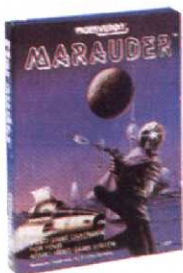
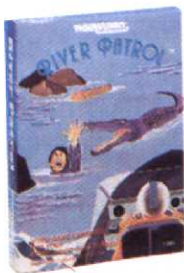

**River Patrol    Marauder    Threshold**

For use with the Atari® Video Computer System™

## TIGERVISION®

Division of Tiger Electronic Toys, Inc.  
909 Orchard, Mundelein, Illinois 60060, Telephone, (312) 949-8100, Telex: 210042 TIGR UR

King Kong™ Trademark of Universal Studios Inc. © 1982 Universal City Studios Inc.    Jawbreaker™ Trademark of Sierra On-Line Systems Inc.  
Atari® and Video Computer System™ are trademarks of Atari Inc.



# This is **COLECOVISION**

## The Arcade Quality Video Game System

### The Most Advanced Video Game System You Can Buy

ColecoVision was designed for what you had in mind—a great game system that's expandable into a great computer system.

### Arcade Quality Graphics

ColecoVision graphics have the superior resolution and brilliant color of real arcade games. And this new advanced level of quality holds true for every part of the system.

### Plays The Best

ColecoVision has arcade quality controls—joystick, fire and jump buttons that make it easy to play. And ColecoVision offers a library of your favorite arcade games like Donkey Kong™ (which comes as a bonus with ColecoVision™), Turbo™, Zaxxon™ and Cosmic Avenger™. Sports and educational games, too. Even ColecoVision's exclusive new Smurf™ game based on the #1 TV cartoon series.

### Plays The Most

ColecoVision plays more games than any other system, because ColecoVision is an *expandable* system. By using ColecoVision's first expansion module you'll be able to play all of the Atari® VCS™ compatible cartridges.

### An Expandable Computer

When you buy ColecoVision, you've already bought a sophisticated computer ready to accept expansion modules of all kinds. And in 1983, you'll be able to "activate" ColecoVision's amazing memory by simply plugging in a keyboard, a printer and other computer accessories. This expansion feature is your assurance that your ColecoVision will always keep pace with "state of the art" developments in electronics.

**ColecoVision—a great game system that's expandable into a great computer system. The most advanced video game system you can buy.**



COLECOVISION EXPANSION MODULE #1  
ALLOWS YOU TO PLAY ALL ATARI® VCS™  
COMPATIBLE CARTRIDGES. AVAILABLE  
IN NOVEMBER.

YOUR VISION IS OUR VISION



**COLECOVISION™**



Dad, This is the system we've  
both been waiting for.  
ColecoVision has everything!  
It plays the best arcade games - It  
looks and plays just like the real  
arcade. And it plays the most arcade  
games. It's got a plug-in attachment  
that will allow us to play all of  
Atari's VCS games!

Bill

P.S. And look at this, Dad,  
ColecoVision is also a computer!  
And that's important - because, you  
know, I don't want to just play games.  
Could we go to the store and take  
a look?



# COLECO





# VISION:

THE NEXT STEP!

## Will This Be the Hot New System?

By ARNIE KATZ

Sensational technological leaps have generated most of the progress in the home arcading field in the first decade since the introduction of a whole new ball game when they placed the crude Pong units that originally dominated that phase of electronic videogames. Then came the convenience and versatility of having programmable videogames on ROM cartridges with a larger resident memory and more detailed graphics. Each class of system has played games substantially better—or at least than the devices which preceded it. Now, here comes the third wave of programmable videogames—up to amounts of resident memory—up to the same 48K as most of the popular microcomputers—and screen RAM that is measured in thousands, rather than hundreds, of bytes. (Screen RAM is the "secret ingredient" in videogame graphics. It helps determine things like the amount of detail moved around the screen.) ColecoVision has the distinction of being the first "third wave" system to hit the market. The shock waves will reverberate for at least the next year, as independent publishers of software

jockey for position in this explosive new segment of the hobby. ColecoVision promises coin-op quality videogames in a home setting, and it delivers on this pledge to a surprising extent. It's not perfect by any means, but ColecoVision just may be the home arcade system of the mid-1980's.

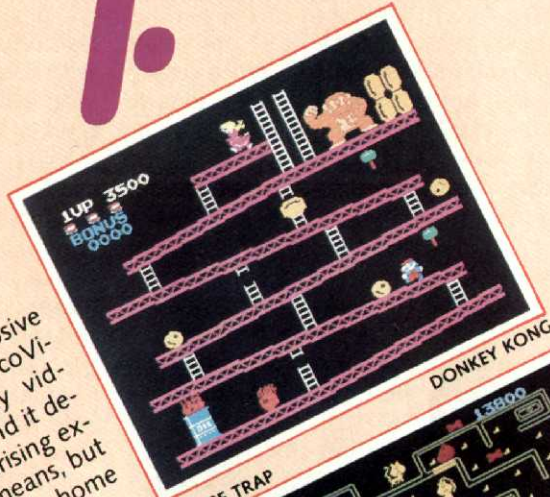

DONKEY KONG

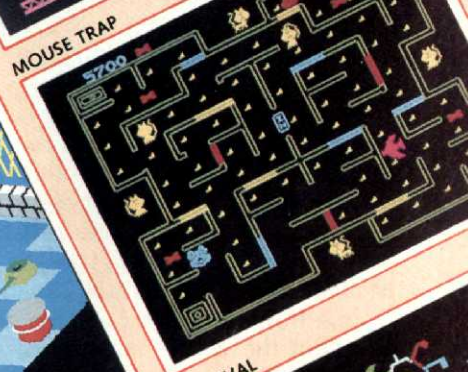

MOUSE TRAP

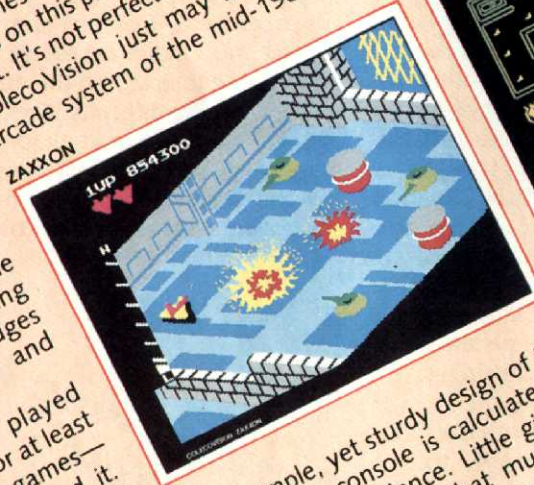

ZAXXON

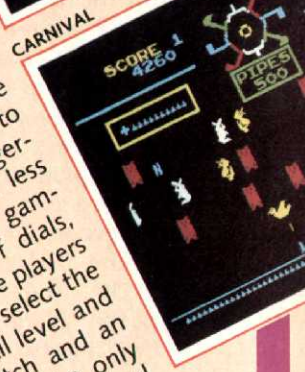

CARNIVAL

The simple, yet sturdy design of the ColecoVision console is calculated to inspire user confidence. Little gingerbread means there's that much less that can go wrong to spoil your gaming. The unit is fairly free of dials, switches and buttons, because players use the controller keypad to select the number of participants, skill level and such. An on/off slide switch and an "instant reset" button are the only controls, both found on the top panel near the front. A pair of niches located at the left rear of the top panel hold the two ColecoVision controllers supplied with the system. The hand-held command de-

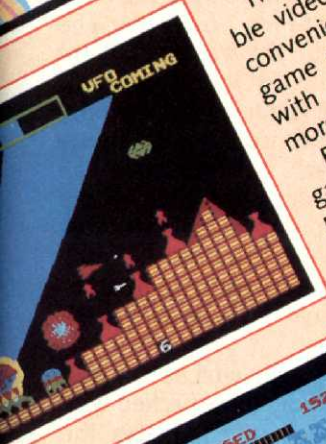



# COLECOVISION

vices, which use Atari VCS-compatible connectors, plug snugly into recessed outlets and are attached to the console with telephone-like coil cords.

Hook-up is about as easy as for any other home arcade. The gamer attaches the AC adapter to the power source and plugs the other wire into the usual RF converter box. Coleco provides an RF unit with the system, though it is essentially the same as those used in conjunction with such machines as the Atari VCS, Intellivision and Astrocade. That's good news for owners of more than one system who like to switch among the various machines during the same play session without a lot of fuss.

The cartridge slot is also situated on the top panel, though toward the left front. Push a game cartridge through the little door covering the slot until it can't go any further into the console, and you're ready to play. It takes a few seconds for the ColecoVision to set up a game from an ROM cartridge program, but the wait is not excessively longer than with other videogame systems. As per usual, it's always a good idea to turn off the system completely when changing cartridges.

The controllers refine the design which Mattel pioneered with the Intellivision. There is a numeric, touch-sensitive keypad laid out about the same as the dial of a touch-tone phone. Pushing the asterisk, located to the left of the "0" on the bottom row, causes the same variation of a given game to reset. Hitting the "#", found immediately to the right of the "0", returns the screen display to the menu. From that list, players can choose a new set of variables to govern the play of the next round.

The joystick portion of the controller is short and stubby, topped by a large circular knob that serves as a handgrip. The stick shaft should have been much longer so that the arcader could apply more torque, even though such a configuration would have made it tougher to store a ColecoVision in a small space.

The responsiveness of the stick isn't quite everything an arcade ace might wish. It's not unpardonably sluggish,

but movement simply isn't as crisp as with some of the gourmet control devices now reaching market. Some upgrading of the joystick wouldn't be a mistake.

The action buttons are side-mounted, one on each edge of the command device. Though no controller has an easier-to-use version of this arrangement, side buttons are indisputably harder to work for many, especially those having small hands.

Making the controllers interchangeable with those used on the Commodore VIC-20, Atari VCS and Atari 400/800 computer systems was a smart move. Many games can be played using special sticks in place of the standard ColecoVision ones. Players must have access to at least one keypad to establish the number of players and the difficulty level, but this presents no problem at all for the solo gamer. The rest of us will have to wait for the arrival of premium-quality controllers with two action buttons.



**Donkey Kong May Be the Best Videogame Ever Packed With A System. . .**



Sound and graphics are unsurpassed in the videogame arena. Colors are rich and deep, animation is as fluid as a Saturday morning cartoon and the sound effects are of coin-op quality. The console we tested produced a sharp, interference-free image on the screen.

One aspect of the console that is as yet impossible to evaluate is hidden discretely behind a little door on the front panel of the machine. This is the interface for the modules which Coleco intends to produce for its system. The first one, which should be available by the time this article sees print, will allow home arcaders to play cartridges intended for the Atari VCS on their ColecoVision. This should be good news for those who want the ColecoVision as a second system but don't feel good about scrapping their VCS cartridge collection.

Other add-ons planned for ColecoVision include: a driving controller for **Turbo** and other similar games, a keyboard to turn the unit into an authentic microcomputer and, perhaps ultimately, an emulator that would permit the ColecoVision to handle Intellivision cartridges.

"All this about the hardware is fine," you may be muttering, "but when is he going to get to the games?" Right now. Although the ROM cartridges do not come close to taxing the memory capacity of the console, their superior audio-visuals raise them above the usual run of videogames. When the price of computer chips falls low enough to make it economically feasible to make more powerful game carts, this system should really be able to lap the field.

**Donkey Kong** may well be the best videogame cartridge ever packed with a system. Though it eliminates the animated sequences that introduce the game as well as each of the individual scenarios, *Donkey Kong* effectively translates the essence of the Nintendo coin-op to the TV screen.

Playable by one or two gamers at a range of four graduated skill levels, *Donkey Kong* spins the saga of Mario the maintenance man. It seems that a giant ape has kidnapped his girlfriend

*Continued on page 125*



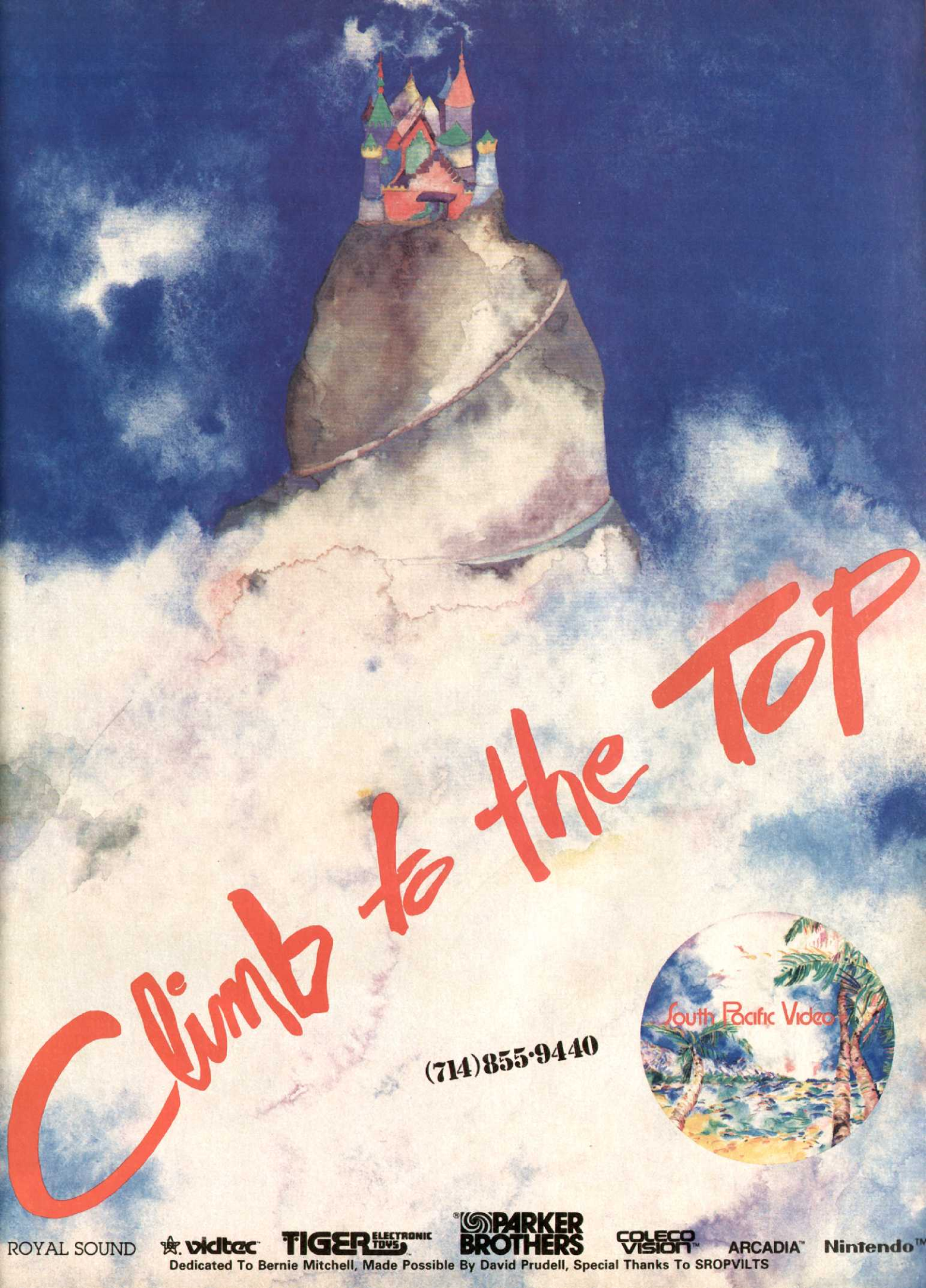

# Climb to the Top

(714) 855-9440



ROYAL SOUND

vidtec

TIGER ELECTRONIC TOYS

PARKER BROTHERS

COLECO VISION

ARCADIA

Nintendo

Dedicated To Bernie Mitchell, Made Possible By David Prudell, Special Thanks To SROPVILTS



**EG Looks at the  
Wide World of  
Gaming Accessories  
to Brighten the  
Holidays of any Arcader!**





# gifts for gamers







VCS AND SUPERCHARGER



ARCADE TIME WATCH

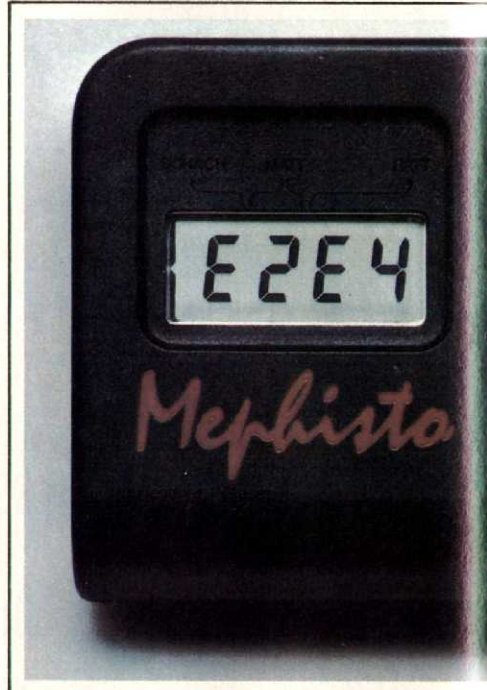

MEPHISTO COMPUTER

## Our Second Annual Shopping List for Prospective Santas

By HENRY B. COHEN

The excitement is building. Christmas and Chanukah are now just a matter of weeks away, and folks from coast to coast are wracking their brains, trying to conjure up the perfect gift for those hard-to-please people on their lists.

If you're thinking about presents for electronic gamers, though the problem may be quite the reverse. The only thing the typical arcader likes better than a score-doubling strategy tip is a gaming gift. The hard part is deciding which of the hundreds of avail-

able items is most likely to light up someone's eyes when they unwrap it.

On the next few pages, the editors of **Electronic Games** offer some suggestions for possible gifts for gamers. It's hardly all-inclusive—we could probably fill an entire issue with delightful gifts—but these are some of the ones we think most arcaders would enjoy.

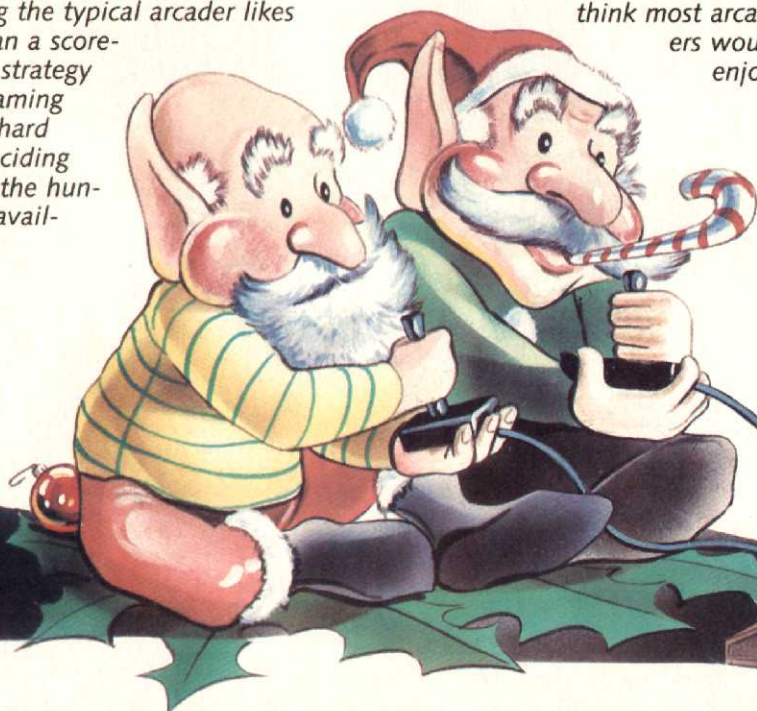

### SYSTEMS AND CARTRIDGES

If your wallet can stand the strain, giving someone a programmable videogame system is a great way to let them in on the excitement of our hobby. See the "Players Guide to Programmable Videogames" in this very issue.

Cartridges are also a great choice as a gift for those who already have one of the eight major home arcade machines. Again, we refer you to the rest of the magazine for some ideas.

### THE EG COLLECTION

What better way to "spread holiday cheer throughout the year" than with a gift subscription to **EG**? Penned for gamers by gamers, **Electronic Games** has quickly become essential reading





INTELLIVISION CASING & WICO TRACBALL



TEACH & LEARN COMPUTER

for anyone interested in America's leading pastime.

And for those who want news and reviews hot off the press, **Arcade Express**, our sister publication, is a bi-monthly newsletter filled with up-to-the-minute gaming information.

For the VCS fan in your life, there's "The Players Strategy Guide", a soft-cover volume that will keep any Atari scoring high.

Lastly, to let everybody know where you stand, there's the official **EG** T-shirt. All cotton, fashionable and comfortable, this stylish topper should top everybody's holiday gift list.

### CONTROLLERS

WICO, the Chicago-based manufacturer of coin-op machine controllers, has a brand new trackball. It offers precise control and comes ready to

plug into any Atari-configured game port. The compatible units include the Atari VCS, 400 and 800 home computer, the VIC-20, and Sears Tele-Game System. In addition, there is a two-fire button version for Apple computers and versions for TRS-80 and Odyssey<sup>2</sup>.

To help keep Intellivision games under control, there's the Injoy-A-Stick disc controller replacement joystick. For only a few dollars, you can obtain better control of your games and maintain total factory appearance. They take but a few minutes to install and only present a problem if your console is fitted into a close fitting game case or center.

An excellent joystick and paddle base, the Pro-Console 1 is attractive and practical at the same time. This unit stores both controller cords and is weighted for better game play when in use. Currently, it is only available for Atari controls, however.

Computability of Milwaukee, WI, has another pair of joystick controllers for VCS-compatible systems. The higher-priced model is the Starfighter, which goes for \$16.95, and the Slik Stik—essen-

tially the same stick, but built of slightly less resilient material and offering a nob-top shaft—retailing at \$9.95. These sticks will be of special interest to left-handed gamers since an extra ten dollars will buy a lefty-adaptor. Five foot long extension cords can also be had for \$6.95.

Console fans—players who prefer using a series of directional and fire buttons in preference to stick-type manipulators—will almost certainly get off on the Starplex, a \$29.95 button-controller with an auto-fire

feature that goes great with

games such as **Asteroids**,

where more than a single shot can appear on screen simultaneously.

And for that sad, but inevitable, day when the shaft of that Atari joystick

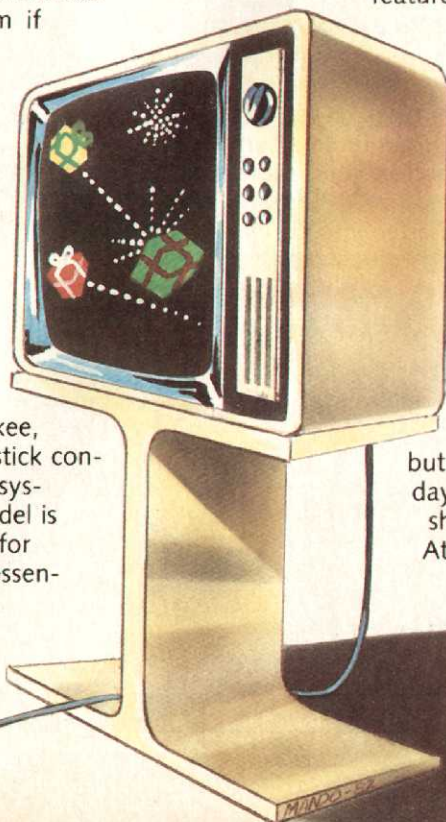





(L TO R) OTHELLO, FROGGER & SCRAMBLE

comes off in your hand—or the button or board itself breaks down—just give the Midwestern version of the Game Doctor, Cliff Blake of Screensonics, a call. For a mere pittance (under \$5), you can get an all-purpose joystick repair kit with a new shaft, action button and board, capable of repairing up to three sticks.

**STAND-ALONES, COMPUTERS, AND ELECTRONIC FUN MACHINES**

The Vectrex is a self-contained vector scan game machine. Containing a 9-in black and white television screen (with color overlays) and a removable controller panel, there is nothing else like it on the market.

Taro from Fidelity Electronics, reads and predicts your future. If you believe in such wonders, this adorable little darling is a must. Plastic encoded Taro cards are inserted into the base of the machine and from them it calculates and provides your reading. An in-



CHILDRENS' DISCOVERY SYSTEM & TLC

teresting and entertaining offering from a company best known for advanced electronic devices.

Mattel's Synsonic drums are a fantastic gift for any current or would-be drummer. They are also a great idea for a child who insists on drums for Christmas but is meeting predictable parental disapproval. Not a toy, but a true drum synthesizer, the Synsonics play into headphones or an amplifier speaker system. In other words, they don't make noise unless you want it. At the same time, they are suitable for professional use and may be played tom-tom style or with drumsticks. Volume increases with the pressure applied to the "drumheads" and with their ability to synthesize cymbals and other percussive sounds, they're unique in the world of musical instruments.

If you march to the beat of a different drummer, Mattel also makes some great electronic gifts for the kids in your life.

The Childrens Discovery System is a gem of a children's computer. It takes audio discs through a slot in its side, and with overlays, both entertains and instructs younger children. This is not a toy.

For the slightly older child, ages 6 - 11, there is the Teach n' Learn computer. This is a 2K machine that takes both an ROM cart and overlay to teach various subjects. The display is LCD and the library of topics is vast.

If you're looking for something exciting, different, practical and educational, either of these products, depending upon the age of the child,

makes an excellent choice for Christmas gift giving.

Going to the other extreme, Mephisto Chess computers are a gift for the adult enthusiast. Not currently marketed in the states, but available from the factory in Munich, Germany, Mephisto is the state-of-the-art in portable machines, and a close contender with Fidelity's Elite and Prestige console models. What sets the big Mephisto touch sensor board apart from the others is its exquisite all-wood craftsmanship. This is a beautiful piece of furniture and a top flight chess computer. It is generally ranked second only to the aforementioned Fidelity units in strength of play, and many enthusiasts find it plays more like a person than other computers do.

Both of these units are expensive and dollar for dollar a bit tough to rationalize, but for those who appreciate quality and design elegance, they're outstanding gifts. As improvements are constantly being made in their 12K programs (including increasing the ROM level), they are worth considering even if they can be



TARO READER

beaten in tournament play by one or two competitors. A simple plug-in cartridge is all that is needed to maintain the latest in Mephisto chess programs.

For the disk flipping crowd, both Gabriel's portable Othello and Fidelity's Reversi are outstanding choices. The electronic Othello is attractively well made and features an excellent LCD display. The Reversi Challenger is all but unbeatable at its strongest level. You make the choice, we love them both.

Coleco, not content to shatter the



# Phaser Patrol



## ENTER THE NEXT DIMENSION

**Turn your Atari® Video Computer System™† into a supercharged video game machine.**

Slip the Arcadia Supercharger™ into the cartridge slot of your Atari® set and enter the next dimension in video game excitement. The Supercharger™ gives your Atari® set the game-playing power of sets costing hundreds of dollars more.

And Supercharger™ game programs cost 40% to 60% less than conventional game cartridges.

Start with Phaser Patrol™, the extraordinary galactic odyssey that comes with the Supercharger™. Plot your strategy on a full

screen sector map. Then fight it out with a challenging enemy on an incredibly detailed battle action screen. Take control of switchable shields, target-locking torpedoes, fully operational instruments, and starbase resources.

Included with Phaser Patrol™ are live action previews of other Arcadia games: **Communist Mutants from Space™**, Fireball™ and Suicide Mission™. They're all a dimension ahead of anything you've ever played on your Atari® set.

† Atari®, Asteroids™ and Video Computer System™ are trademarks of ATARI, INC. ARCADIA CORP. is not related to ATARI, INC.

© ARCADIA CORP., 1982.

**ARCADIA**  
CORPORATION  
**ARCADE ACTION COMES HOME™**

**"Phaser Patrol™ is the best home video game I've ever played on any set."**

Andy Breyer  
Champion

1981 International Atari®  
Asteroids™ Tournament

*"The graphics on Phaser Patrol™ are as good as on many arcade games. And the game itself is designed to stay challenging. Even to me."*







MEPHISTO

gaming world with its excellent ColecoVision "third wave" programmable videogame system, has produced another stand-alone gem, **Frogger**. It provides a brighter display than its predecessors, **Pac-Man** and **Galaxian**. Virtually anybody would be charmed and thrilled to find this Frog in their Christmas stocking.

More stand-alone items that look to be good gift-giving bets include: the GCE game-playing wristwatches, such as the original Game-Time and the newer additions, Arcade Time, which plays a series of four space games, and Sports Time, which offers wee simulations of several popular team sport contests.

GCE has also introduced "N-Counter", a series of game playing pocket calculators. Chase-N-Counter offers maze-chase challenges and Space-N-Counter treats stand-alone fans to state-of-the-art LCD arcade-action games in addition to tallying digits.

Reversi fans will want to look at Fidelity's excellent Reversi Challenger system, part of their famous "Challenger" line that includes chess, checkers and backgammon computers, among a host of other skill contests.

### OTHER CHRISTMAS GOODIES

Recreational Products Play-n-Store is one of our favorite videogame centers. It isn't expensive and yet manages to attractively hold an Atari VCS or Intellivision and 21 game carts. It will store the Intellivision with Injoy-A-Sticks installed, or it has room for a pair of WICO joysticks and the VCS. A best buy for the gamers in your life.

Southern Case's universal game case will enable you to carry a VCS, Intellivision or Atari 5200 in style. It will also house game carts and controllers, the number varying with the console used, and it's both lightweight and at-

tractive. Who knows, with the case in their hand, it may even get some players away from their TVs long enough to actually receive the gift.

The Arcadia Supercharger is a must for any VCS owner. This unit, a great favorite of ours, gives the VCS enough of a kick to make it competitive with the best of 'em. It will not turn your VCS into ColecoVision, but it will add life and sparkle and make you feel you have a brand new system at a most reasonable cost.

And speaking of gifts, not electronic, there are Beamscopes. A full discussion of these products will be found in "Test Lab". Those with a 13- to 19-in. TV can work wonders in blowing up your picture. The console model is a bit more expensive and so we recommend appropriate time spent when considering it, and a personal audition in this case is a must.

As the years go by, each holiday season becomes a bigger and better fantasy land for electronic gamers. Beyond even the games themselves, the afterburner market—deluxe joysticks, system holders and the whole, wide, wonderful world of gaming paraphernalia—is lighting up the holidays for all of us.

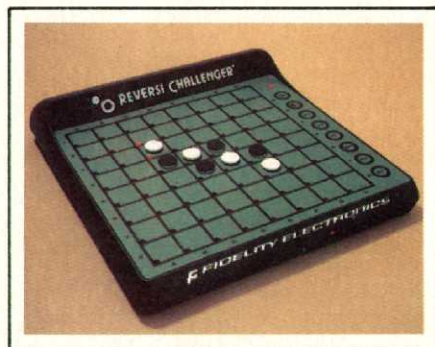

REVERSI CHALLENGER



# 9 COMMAVID™

Presents

## PLAYABLE VIDEO GAMES for your Atari® Video Computer System™

CommaVid video games are designed to keep you involved. New games where your pleasure increases as your skills develop. More than just flashy graphics, you'll find challenges that hold your interest play after play.

### THE REVIEWERS REPORT:

"One of the more interesting new cartridge manufacturing companies is the Illinois-based CommaVid. They're releasing several cartridges for use in the VCS . . . and consisted of some of the best this writer has seen! . . . Our initial impressions rate the company's offerings 'Impressive!'"

*Video Entertainment, October '82*

Aliens stalk the corridors. A single robot survives to battle them.



### OTHER VIDEO GAMES FROM COMMAVID:

#### COSMIC SWARM™



Fight off the attacking alien termites before they jam your space station.

#### ROOM OF DOOM™



Can you escape from the gunmen trying to annihilate you?

#### MISSION OMEGA™



The last mission from earth, and only you can save the universe.

**CommaVid Inc., Box 3308, Fox Valley Center, Aurora, IL 60505**

Atari and Video Computer System™ are trademarks of Atari, Inc.



# BAD NEWS FOR INTE



\*Intellivision is a trademark of Mattel, Inc. Imagic is not affiliated with Mattel, Inc.

So you think you can beat every game made for your Intellivision® system, huh? Think you're pretty tough stuff, huh?

Well, so did Billy Grubb up there.

Until he played IMAGIC'S new Demon Attack™ Atlantis, Microsurgeon™ and Beauty & the Beast for the Intellivision system.

First, Bill played Demon Attack. Wave after wave of deadly demons bombarded Bill with lasers. The tricky demons split in two, even let loose with a few fireballs. But somehow Bill managed to wipe them out and take off into space searching for the demons' home base.

Unfortunately for little Billy, he found it.

Next, Bill gave Atlantis a shot. The Gorgon attack vessels filled the skies above the underwater city of Atlantis. Bill fought back from his two missile posts. As night fell, and the Gorgon death rays took their toll, Bill launched his star fighter and attacked the enemy head-on in the air.

But little Billy was no match for the fierce Gorgon warriors. No match for IMAGIC.

By now, Billy was feeling a little sick. He was ready for Microsurgeon.

Using a surgical robot probe, Bill began exploratory surgery on the

**Demon Attack**

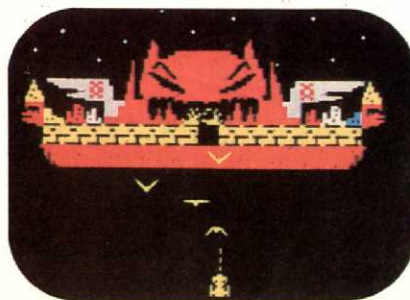

**Atlantis**

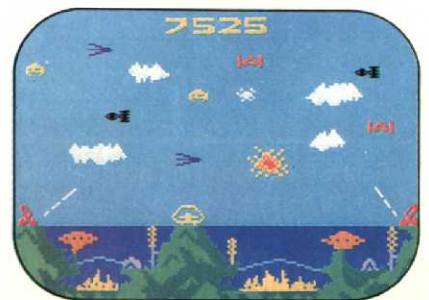



# LLIVISION OWNERS.



©1982 Imagic.

patient. The status report warned of serious problems in the heart and lungs. Bill raced down the circulatory system fighting white blood cells and bacteria all the way.

The beating of his patient's heart was deafening as Bill raced against the clock to remove the cholesterol blocking the arteries. Then the beating stopped.

And so did Billy.

Next, Bill grabbed for Beauty & the Beast. "This'll be easy," he said with his last glimmer of cockiness.

It wasn't.

After climbing up a building through dozens of open windows,

jumping over rolling boulders, narrowly avoiding vicious rats, and ducking under deadly birds, Billy was still four stories away from the beast that was bullying his best girl. Then he fell off the ledge.

Bye-bye, Biiiiiiiiiiiiiiyyyyyy!!!!

Let this be a warning to all you cocky, know-it-all, self-proclaimed video game wizards out there:

Laboratory tests have proven that IMAGIC games, when played in large doses, may be hazardous to your self-esteem and cause chronic Huggedigitosis (sore thumb).

In other words, our games are created by experts for experts.

## Microsurgeon

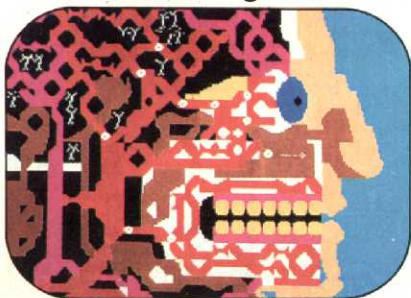

## Beauty & the Beast

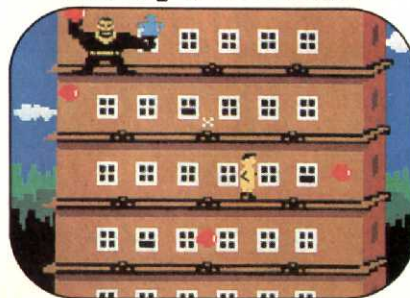

Created by Experts for Experts.



# You Can Be A Game Designer

By HAROLD GOLDES

## Plan Now for a Career in Gaming

Twenty years ago it was fantasy: cowboys or soldiers or space cadets. Today it's fantasy plus: video lassos, 3-D tank battles, hands-on space warfare. Now, for almost every dream there's an electronic game that makes the dream a reality.

Still, some have other dreams. Their minds are agile, their fingers deft. Their eyes see two moves ahead. And yet to certain game players, play alone is not enough. The physical and mental challenge of marathon game sessions leaves them fascinated by the ultimate video wizard: the electronic game designer.

They are curious: "How would I do it?" or confident: "I could do it better." But where do they go from there? How do you turn a spark of creativity into bomb bursts and laser blasts? Here are some answers, some suggestions and some advice. Here is a peek behind the scene into a career that could only exist in the twentieth century.

Let's start with basics. Education tops the list.

Some game designers have a solid technical education. Specialties differ, but the focus is on the hard sciences. For example, the creative team that produced Midway's *Tron* includes four designers with masters degrees in electrical engineering, computer science and industrial art. Ace Atari designer Chris Crawford (*Eastern Front*, *Scram*) and Silas Warner (*Robot War*,

*Castle Wolfenstein*) of MUSE were both physics majors.

Other people come to design with backgrounds in english, art and music. Don't be surprised to find that the field has its share of MBAs and accountants. Game designing is a business. While a designer must know a bit about bytes and number crunching, some of the most important numbers are dollars and cents. Balance sheets and budgets may not strike you as glamorous (you're probably right), yet they are as much a part of game designing as color and sound.

Knowledge-wise, the bottom line in this profession is computer programming skill. Programming is the art of







## RICK COLBY THOUGHT HE WAS HOT STUFF.

Too bad about Rick. He was sure he could beat almost any game made for his Atari® Video Computer System™.

Then he played Imagic's Fire Fighter™.

Rick knew he was in trouble the second he leaped off the fire truck and began hosing down the flaming warehouse.

As the fire leaped from floor to floor, and the panicked victim climbed higher and higher, Rick tried desperately to reach the top floor with his ladder.

But it was just too late. The warehouse was turned into a burnt-out shell.

And so was Rick.

Please don't let this happen to you. Fire Fighter and all of Imagic's video games are created by experts for experts. Do not play this video game if you are a weasily, weak, uncoordinated nerd.

Unless you want to wind up like Rick.

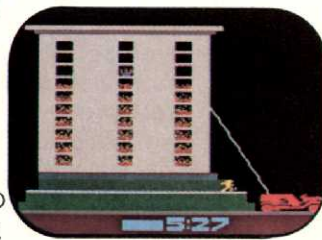

For Atari® VCS.

**IMAGIC**

Created by experts for experts.



How do you develop "hard" and "easy" versions of the game? The designer must answer questions like these first.

The next step is translating the answers into a language a computer understands. This language is called a programming language. Several languages exist. BASIC, COBOL and FORTRAN are well known examples. Virtually every arcade or home videogame is programmed in a language called "assembler". Assembler language is not for the fainthearted. Assembler programs are difficult to write and twice as hard to read. Imagine trying to make sense of 10 pages of cryptic statements like:

```
LIM DC1, BUFA
LOOP LNA DCO
SNA DC1
```

Unlike humans, computers have no problem following assembler instructions. Using assembler, designers write short, efficient programs that run extremely fast on the microcomputers inside today's games. The result is the sure sign of quality programming: smooth animation and rapid player response.

Fine you say. Where do I learn more about programming and micros? Try universities and colleges.

Most institutions offer degrees in computer science. A B.A. or M.A. in computer science is an excellent springboard to a career in game designing. Are you in college now? Talk to your advisor. Take some electives in programming, electrical engineering and math. Out of college? Don't worry. Graduate and undergraduate courses are usually available to the interested. Aim for courses that teach microprocessor fundamentals and assembler programming.

Another possibility: computer stores and computer users' groups. Both provide formal and informal sources of information on programming micros. You will meet professionals and talented amateurs who may have the same interests.

What about commercial programming schools?

Be careful here. These schools train people for jobs in business, not the entertainment industry. The emphasis is on data processing. Basically, you get a practical preparation for jobs in banks and insurance companies. Do not expect instruction on computer graphics or playfield mechanics. Your

training will be shorter, faster and less comprehensive than college course work. If you decide to go this route, check the school's placement records and its standing with the Better Business Bureau.

Alright. You've got a glimpse of the training needed by game designers. You might be thinking: "I guess it's time for the fun part."

Guess again.

Playing videogames is fun. Designing them is serious work. Some people think designing a game is only slightly harder than having a bright idea. Like film studios and TV networks, electronic game companies have files packed with unsolicited brainstorming from eager (but unknown) creative geniuses. Four-page essays describing the exquisite details of a videogame are about as popular as letter bombs. Words count a lot less than knowing how to translate ideas into action and strategy.

In order to design games, the ability to think logically and keep track of de-

## **Getting Fundamentals Down Pat Now Can Help You Go From Just Playing Computer Games to Actually Designing Them**

tails is essential. "Don't underestimate the planning that goes into designing a videogame," advises John Pasierb.

He should know. As Vice President of Engineering for Bally Midway, Pasierb has been involved in developing arcade classics like **Galaxian** and **Omega Race**. "Everyone thinks they know how to design games," says Pasierb. "But there are many, many elements to game designing and there's no formula for creating successful ones."

A skilled designer can identify these elements. And, according to Pasierb, this critical eye for what works and what doesn't can be developed with

practice on the job.

To illustrate, Pasierb cites details the average game player takes for granted: the size of objects on the playfield (asteroids, ghosts); the choice of control options (button or joystick); the range of movement of the on-screen player (unlimited, fixed).

A game creator is more than a technician. A designer should be able to communicate; to explain his ideas in terms a non-technical person can understand. At times a designer may need the skill to persuade others, to "sell" an idea he believes in. Occasionally, and this is hard for anyone, a designer must be able to compromise by accepting changes to cherished ideas and visions.

And while we're on the subject, sensitivity and personality play a key role too. Silas Warner, Manager of Research and Development at MUSE Software believes, "In games design, it's the human element that counts. The human interface is paramount. It's important to be a person who knows how to interact with others."

Warner believes strongly that game designing is the wrong career for people whose lives are focused on computers. Warner thinks that the "hacker", the programming addict who lives at his terminal, makes a poor designer. "Hackers relate to computers as number crunchers," adds Warner, "and a game is more than just the numbers inside a machine."

John Pasierb thinks a designer needs to be flexible, a team player and, above all, highly motivated. People like this, admits Pasierb are a "minority." What about being a good game player? "Irrelevant" says Pasierb, "Being a good strategist is more important."

In short, the word is this: To be a game designer you need talent, training, maturity, special skills and a particular kind of personality. The best designers are well-rounded people, not one-sided computer freaks. Instead of burying himself in a terminal, a designer uses the computer as a tool to communicate with and entertain his audience.

Right now the designer is typically an experienced programmer working alone or on a team and creating a single game from start to finish.

But tomorrow?

Explosive consumer demand, corporate competition, more powerful microprocessors, cheaper memory and, perhaps, images stored on vid-

*Continued on page 126*





## GARY LARSEN THOUGHT HE HAD ALL THE ANSWERS.

Gary had an IQ of 162. He never got anything less than an "A" on his report card. He was a wiz at chess.

Then it happened.

Gary plugged Imagic's Riddle of the Sphinx™ into his Atari® Video Computer System™.

As Gary slowly, carefully made his way across Egypt's mysterious Valley of the Kings, he was attacked by rock-throwing thieves, plagued by scorpions, and tortured by thirst.

Yet he went on.

After passing the Sphinx, the Temple of Isis, the Great Pyramids, he reached the Temple of Ra where he presented all his treasures.

Unfortunately, he did

not have the correct offering. Ra was not satisfied. Gary had to go back and try again.

And again. And again. And again. And again. And again. And again.

Here you see Gary as he is today. A veggie. Zonked out. Totally.

This is a warning. Imagic games are created by experts *for experts*. Do not try to solve the Riddle of the Sphinx if your IQ is equal to or less than your belt size.

After all, a brain is a terrible thing to fry.

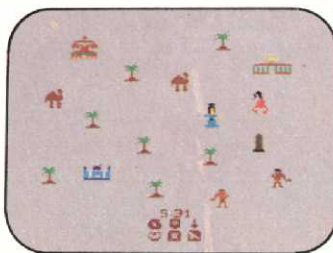

**IMAGIC**

Created by experts for experts.

For Atari® VCS.



# PROGRAMMABLE PARADE

## Go On Safari with the King of Swing!

### PITFALL

Activision/VCS

Talk about your ground-breaking videogames! Dave Crane's *Pitfall* is the most full-bodied adventure ever designed for the VCS with both above-ground and subterranean levels visible to the gamer.

Rendered in a beautiful three-quarter perspective, arcaders guide their on-screen surrogate (a pitch helmet-wearing chap known as "Pit-fall" Harry) over and under a variety of scenarios in search of several types of treasures. So far, we've uncovered moneybags and gold bars, but this game has so many twists you're never sure *what* will turn up next on the screen.

The split-level adventure pits "Pit-fall" against a variety of dangers. Deadly scorpions regularly patrol the lower levels, as disappearing tar pits and crocodile-stacked lakes abound upstairs. Players are armed with a trusty "jump" button which is used *Donkey Kong*-style, only here Harry can leap not only over individual menaces, but whole lakes as well. Some lakes are easier than others, too.

Early on, the lakes have swinging vines overhead. A well-aimed jump will vault Harry onto the vine, allowing a hardy soldier of fortune to swing, Tarzan-like, over the reptile-infested pit. Ah, but *other* bodies of water have no such handy overhead rope, just the



PITFALL

"crops". Split-second timing—not to mention nerves of steel—are required to cross these lakes. Observant gamers will notice that the beasties open and close their deadly jaws with metronome regularity. Just as those huge maws are snapping shut, Harry must leap-frog from crocodile to crocodile before they reopen their yaps.

*Pitfall* is chock-full of such clever touches, with a variety of screens and scenes formidable enough to qualify it as the first player-created videogame "movie" with the action changing from game to game. Gamers who loved previous quest-type contests for the VCS will hardly believe their eyes when they behold the wonderland Crane has created, complete with appropriate audio accompaniment.

Incredibly innovative, *Pitfall* is the sort of original and highly-playable program that vaulted Activision to prominence. Unquestionably recommended.

### DONKEY KONG

Coleco/ColecoVision

Coleco has taken a different tack than some of the other videogame manufacturers who've chosen to include a free cartridge with their hardware systems. Some machines come packed with "bonus" cartridges that just as easily could have been left out of the software line entirely. It's as though such companies are saying, "Here, take this absolutely free vid-

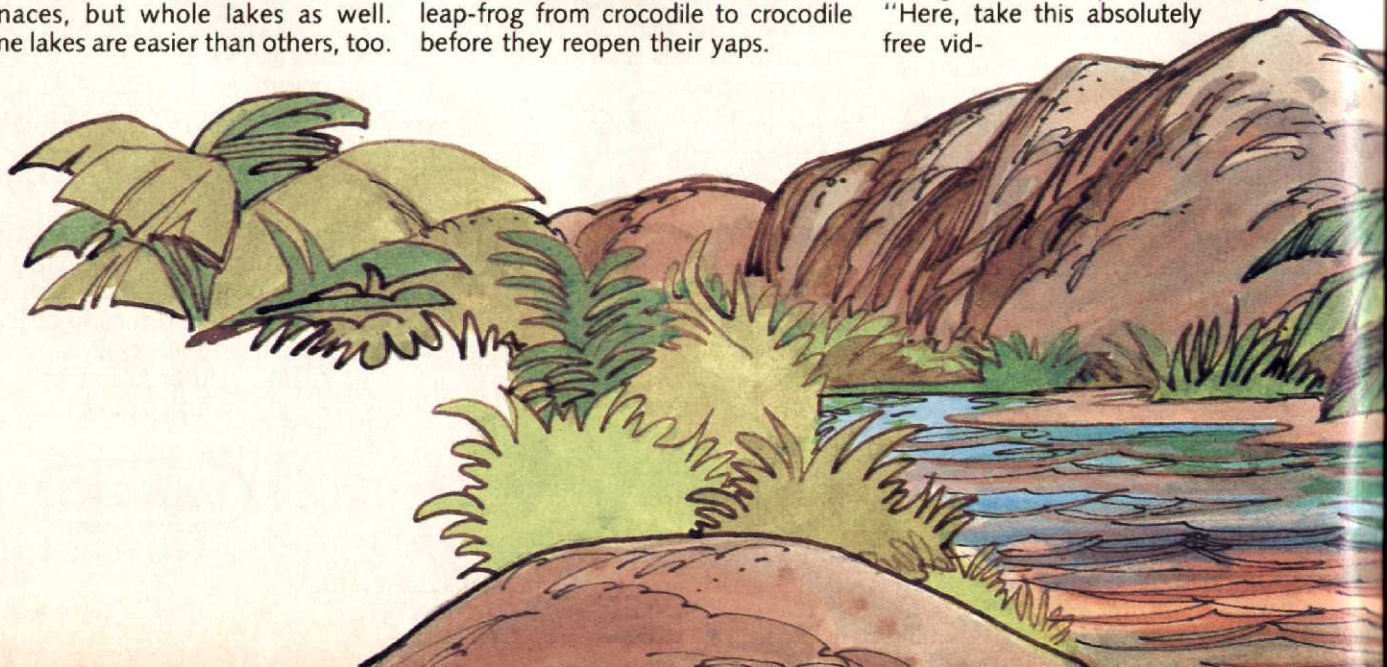



eogame! We really hope you enjoy it, even though we don't think we could sell it to you separately if we gave you a choice."

No one can level the charge of stinginess against Coleco. Not only would **Donkey Kong** be a welcome addition to any publisher's videogame catalog, but it is really and truly one of the finest cartridges produced this year. Now, that's what I call a bonus cartridge. . .

*Donkey Kong* is, of course, the home edition of the coin-op machine that has done so well for Nintendo. There have been a few little compromises along the way, but the ColecoVision version is close enough to the arcade machine to satisfy anyone. The designer has, for example, eliminated the animated sequences that are found at the beginning of the game and between scenarios on the coin-op. Some may miss these interludes, but removing them doesn't really detract from the overall enjoyment of the game.

And what a game it is! The car-

tridge's 24K of programming results in a game that features both super-duper graphics and play-action quick enough to test anyone's reflexes. The smooth animation of the giant gorilla is especially good.

For those who don't go to the commercial game parlors, *Donkey Kong* is the name of a huge ape. The sinister simian kidnaps a girl and climbs up a half-finished skyscraper. As Mario the love-sick maintenance man, you must climb up the ladders to get to the girder at the top of the screen where Donkey Kong is holding your girl friend. The gorilla isn't anxious to turn his prize loose, however, so he tries to stop Mario by rolling flaming barrels along

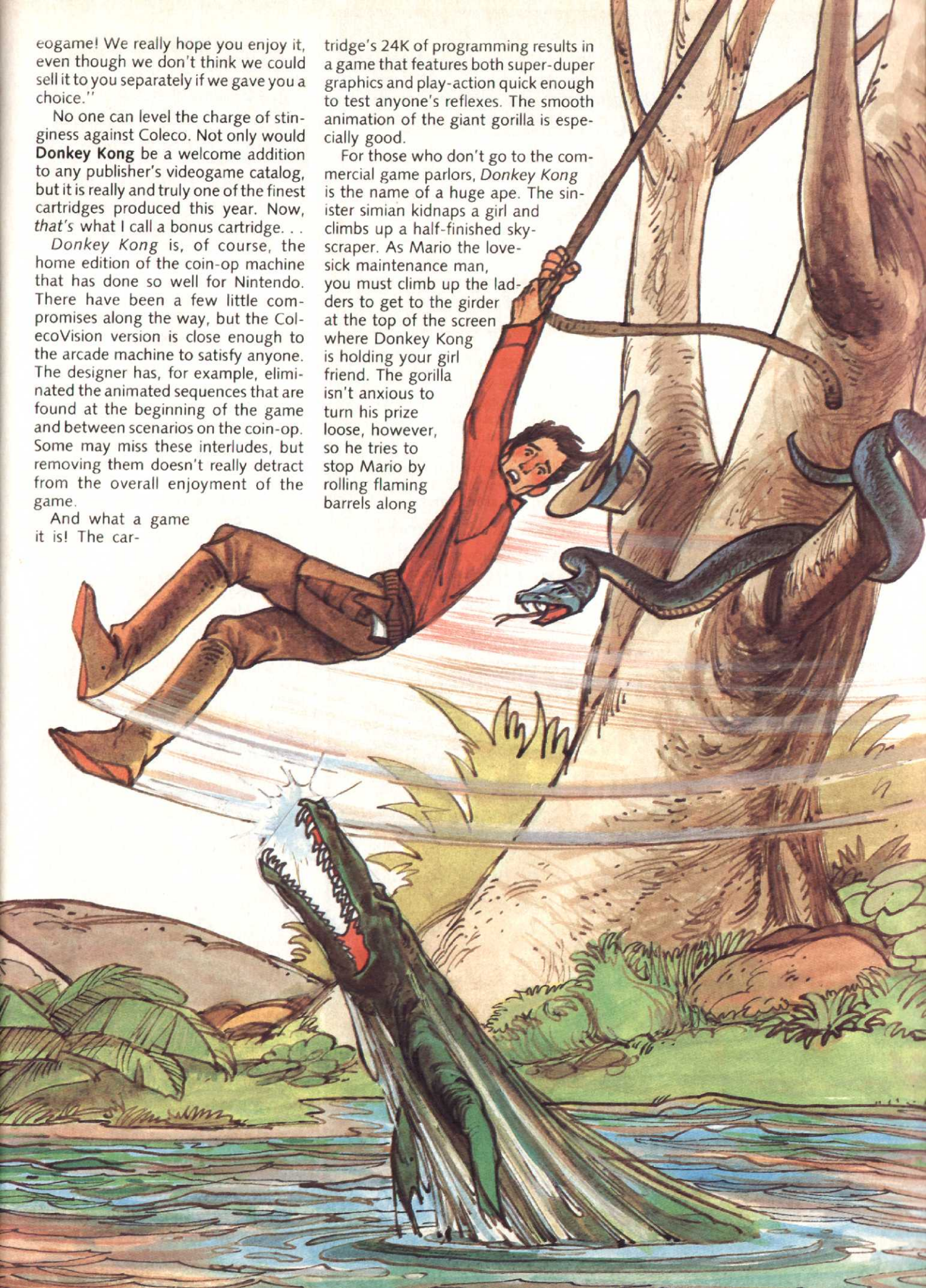



WE  
BUY

# WANTED!

WE  
SELL

## USED VIDEO GAME CARTRIDGES (for Atari VCS)

Largest Dealer  
Of Used Cartridges  
In U.S.  
(More Than 60 Different  
In Stock At All Times)



You MUST Send A  
Self-Addressed,  
STAMPED Envelope To  
Receive Our Buying  
& Selling Price List  
Print Clearly.

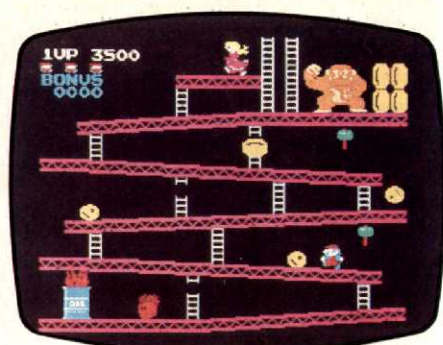

DONKEY KONG

the girders at the would-be savior.

Mario has two ways to stop this attack. He can either leap over the barrel—done by pushing the left-side action button—or smash it with one of the hammers which hang conveniently from the undersides of two girders. If Mario leaps up and snags the hammer, he has roughly 20 seconds in which he can break any casks that rumble his way. To keep the game from getting too unbalanced in Mario's favor, the designer prevents him from being able to climb while the hammer's active. Of course, you can position Mario right at the bottom of a ladder while the hammer flails away and then scoot to the next girder when it disappears, but such maneuvers still run some risk.

At the easiest skill level, you have five Mario's to send scrambling up the ladders one at a time. If one is eliminated, the next one starts right at the beginning.

On the other hand, if Mario makes it to the top, Donkey Kong snatches up the girl and climbs to a higher perch on the building. In the second scenario, Mario must remove bolts which are holding Donkey Kong's roost in position by leaping over them. This level also introduces bonus prizes in the form of several of the girlfriend's possessions. They are scattered around the second and third screens, and Mario scores extra points any time he touches one.

Removing all the bolts dislodges the big ape, but even this setback won't finish the monstrous monkey. He just picks up his victim and climbs still higher to the third—and final—screen. This time, there are elevators among the girders and Mario will have to hop from one to the next in order to get to the top of the playfield where he can, at long last, rescue the poor woman.

Once the easiest difficulty setting is mastered, this three-phase game can be played at three more progressively difficult levels. Each difficulty level

### Just In Case

For Protecting, Storing and Transporting Your Atari\*  
The new Atari Carrying Case holds the base unit, 2 joysticks, a set of paddles, the adaptors, and 4 cartridges. The cartridges, placed on top of the base unit, are snugly secured by the thick foam inside the lid. Removable lid allows in-case operation . . . . . \$22.95  
Deluxe Model (holds 16 cartridges). \$44.95



Visa and MasterCard Accepted

Satisfaction Guaranteed!  
Send check or money order to:

Cases Inc. P.O. Box 33820 Seattle, WA 98133 (206) 365-5210

\*Atari is a Trademark of Atari, Inc.



# ATARI® OWNERS!



## GET THE GAMERS EDGE™

PATENTS PENDING

### INNOVATIVE DESIGN TOTALLY ELIMINATES HAND FATIGUE!

- Attaches Easily
- Play Longer
- Great for Children
- Order Now for Christmas
- Rapid Fire Easily
- Score Higher

HOLDS ATARI®  
JOYSTICK

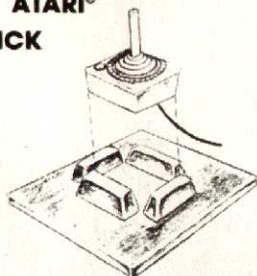

DEALER INQUIRIES  
INVITED!

MAIL TO:  
**K.M.S. ENTERPRISES**

12922 Harbor Boulevard  
P.O. Box 666  
Garden Grove, CA 92640

ATARI® IS A REGISTERED TRADEMARK OF ATARI INC.

Please send me \_\_\_\_\_ units

Name \_\_\_\_\_

Address \_\_\_\_\_

City \_\_\_\_\_

State \_\_\_\_\_ Zip \_\_\_\_\_

All Orders Add \$2.50  
Shipping and Handling

CA. Residents add 6% Sales Tax.

Allow 4-6 weeks for delivery.

Send Check or M.O.—NO C.O.D.'s

Satisfaction Guaranteed or Your Money Back.



is usable in both one- and two-player contests.

*Donkey Kong*, in short, is one "gift horse" you won't mind looking right in the mouth. It makes a fine beginning for the ColecoVision system.

## SPACE HAWK

Mattel/Intellivision

Since running out of topics for sports simulations—and discovering that, no matter how true-to-life they may be, sports-oriented videogames don't have the mass appeal of SF and/or arcade titles—Mattel has started churning out a series of partially-successful but generally frustrating action contests. **Space Hawk**, the latest in the series, offers an intriguing, and totally unique, play concept. Rather than manning a spaceship and then blowing away aliens, asteroids, et al, *Space Hawk* offers gamers the appealing proposition of manning a...well, a man.

Drifting through space, propelled by a thruster jet-pack and armed with a rifle-like weapon that shoots fireballs, gamers manipulate a

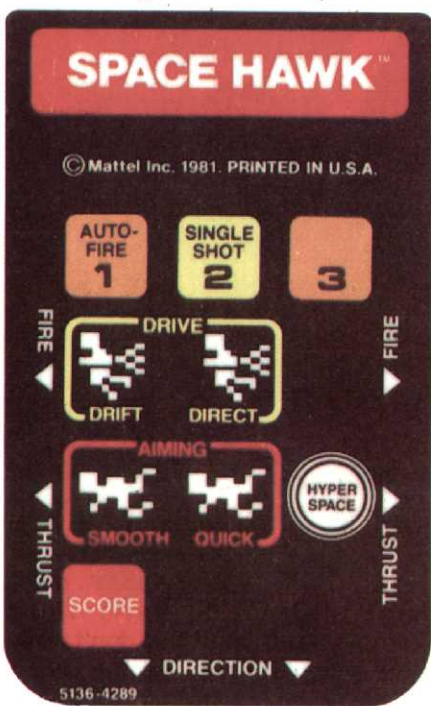

SPACE HAWK OVERLAY

stranded human space-soldier. The enemy consists of a flight of android space hawks and deadly, floating bubbles of poisonous gas.

Okay, now you're all waiting to hear our usual song-and-dance regarding the inadequacy of the Intellivision controllers for action-style gaming, right? So it won't be necessary for us to tell you that the disc will inevitably

# ORB IT!

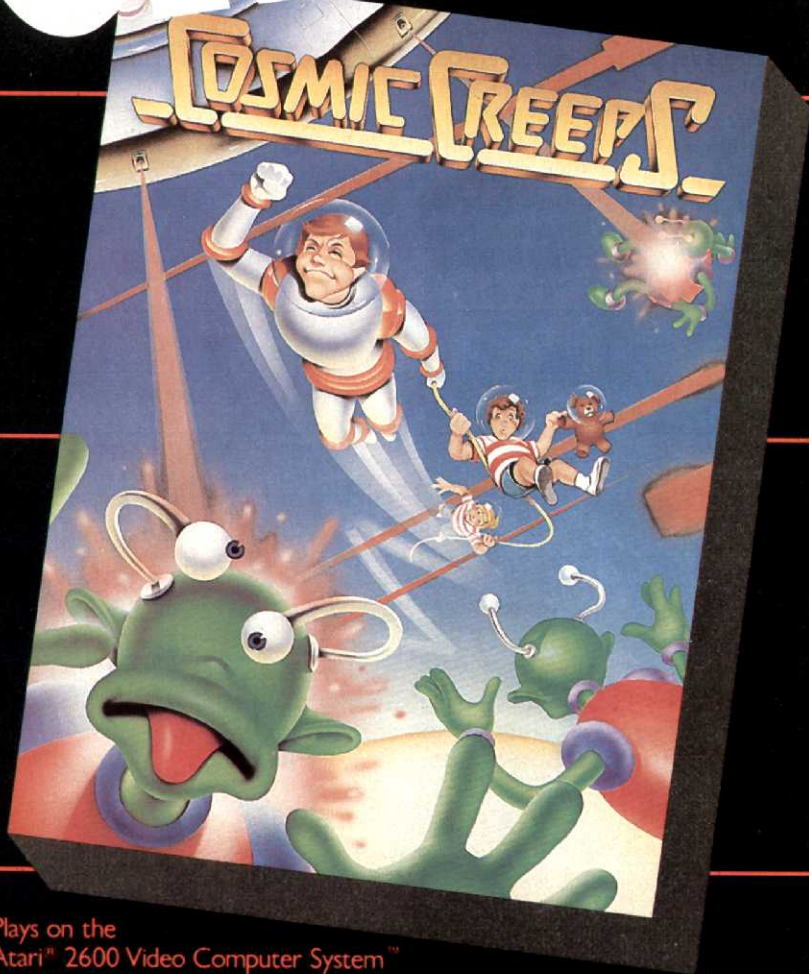

Plays on the  
Atari® 2600 Video Computer System™  
and Sears Telegame® Video Arcade®

**Cosmic Creeps** will send you right into orbit—out of this world to a galaxy where Space Skeeters carry unsuspecting Orbinauts into oblivion. Where Creeps are constantly on the attack. And where it's up to you to save an entire generation of Cosmic Kids.

Even the most space-weary videonauts will love *Cosmic Creeps*. It's a test of astronomical skill, strategy and stamina. And it's a lot of fun.

For the whackiest blast-off ever, take a trip to the store and get *Cosmic Creeps*. It's a space game from a different universe.

**Telesys**  
**FUN IN GAMES.**

43334 Bryant Street, Fremont, CA 94539

Atari and Video Computer System are trademarks of Atari, Inc. Telegame and Video Arcade are trademarks of Sears, Roebuck and Company.



cause problems in controlling your star-spanning space avenger. What might surprise you, however, is our disappointment in the graphics themselves. The space soldier is so badly rendered that it becomes necessary to play the game in the **Astrosplash**-style "auto-fire" mode. Only by monitoring the source of the laser-balls being constantly fired, will average gamers be able to tell exactly in which direction the on-screen surrogate is facing!

Another problem is the inadequate sound effects. Despite evidence to the contrary—several new Intellivision-compatible Imagic videogames offer incredibly realistic audio—gamers might well think that the only explosive-like sound the system is capable of producing is the cap-pistol crack sound Intellivisionaries have been listening to since **Space Battle**. This anemic accompaniment doesn't cut the cheese anymore. The audio for the soldier's fireball weapon, on the other hand, is a wonderfully evocative whoosh that almost single-handedly carries this cartridge—along with the excellent fireballs themselves, and the fine, robotic animation of the space hawks.

Since this is, essentially, a prettied-up version of **Asteroids**, it should have been a lot prettier. Instead, weak graphics and mediocre control turn take yet another potential smash into a flawed but interesting contest. The concept of controlling a jet-pack space grunt is, of itself, fascinating enough to keep Intellivision fans satisfied. Nonetheless, it is undeniably sad to see no sign of improvement in the Intellivision line. The first cartridges remain the finest, while the same outfits' programs for the much-criticized VCS show astonishing technical advances. The question still remains: Why haven't the Mattel programmers/designers overcome problems that have plagued their software since they began producing action contests? Why is the first Intellivision science fiction game, **Space Battle**, still the best arcade-style title in the entire line? With the ever-increasing sophistication of both videogames and videogamers, standing still begins to look like going backwards—and that's something no system can handle.

## SHARK ATTACK

Games By Apollo/VCS

Take a deep breath, gobble game lovers, because your favorite type of

videogame is heading beneath the waves. The arcader uses the joystick to control a series of three divers, available one at a time as the previous one in use heads to Davy Jones' Locker, in an aquatic treasure hunt for diamonds. The idea is to swim through the coral maze, collect the diamonds strewn along the watery corridors and get them back to the surface.

And what would an undersea treasure house be without a bit of finny menace? The terror here is capably handled by sharks which swim through the maze and attempt to bring involuntary retirement to any diver unlucky enough to get in the way.

A special shark cage provides an oasis of safety in this dangerous underwater world. Some variations allow the diver to control the opening and closing of the cage door—a useful aid when the shark is near and it's feeding time—while the cage operates randomly in others.

SHARK ATTACK

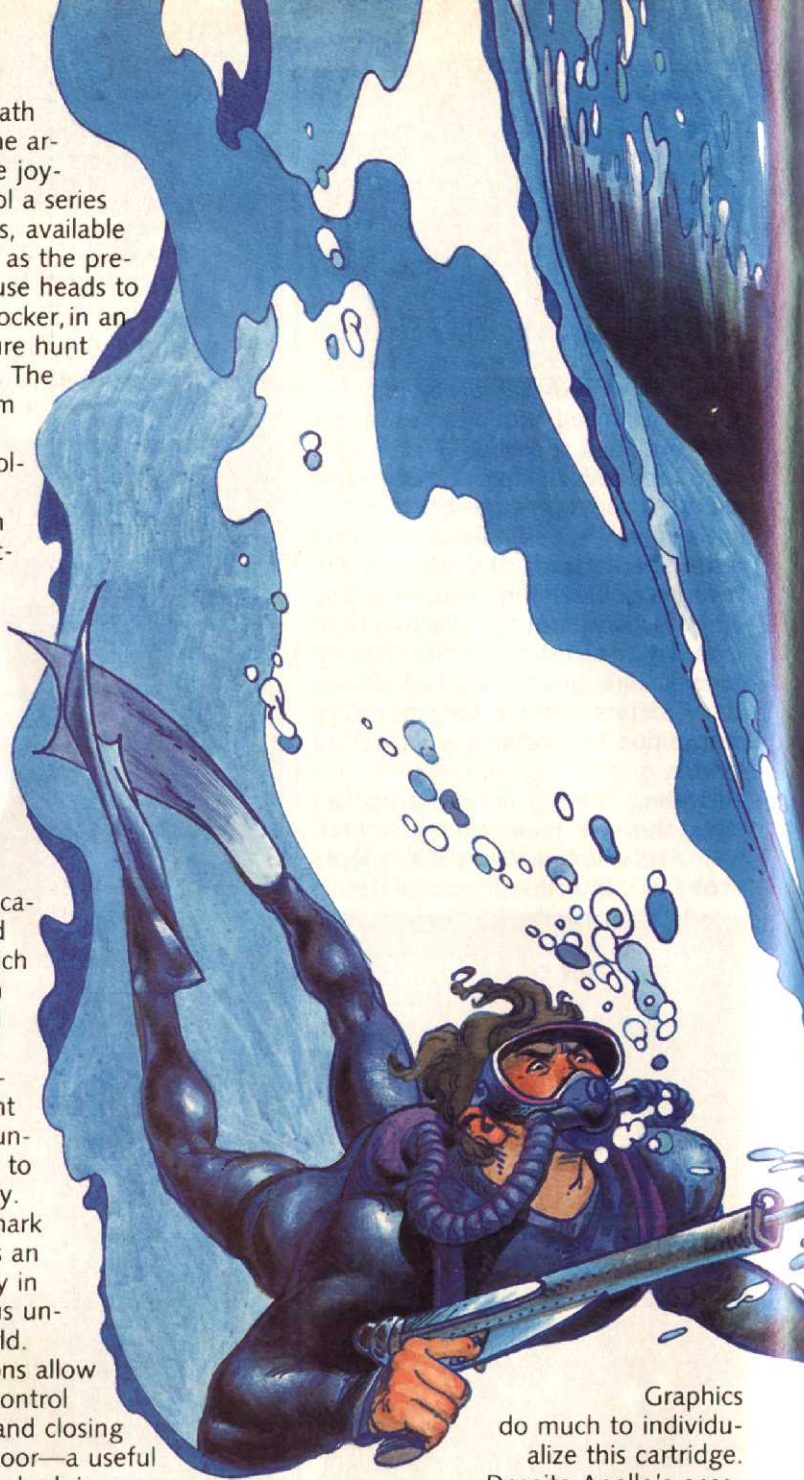
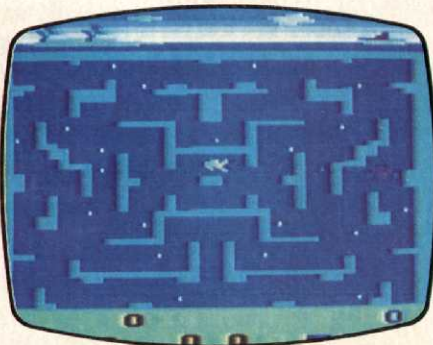

Graphics do much to individualize this cartridge. Despite Apollo's occasional tendency to lavish visual flourishes on elements that don't really figure into the game, like the diver's ship riding the ocean at the top of the screen, **Shark Attack** is certainly one of the company's better looking efforts.

## TOWERING INFERNO

U.S. Games/Atari VCS

The subject of violence in videogames, though not exactly a topic for heated debate, is nonetheless an issue which misguided critics of electronic gaming jump on repeatedly. **Towering Inferno** is the latest example of an action videogame that puts



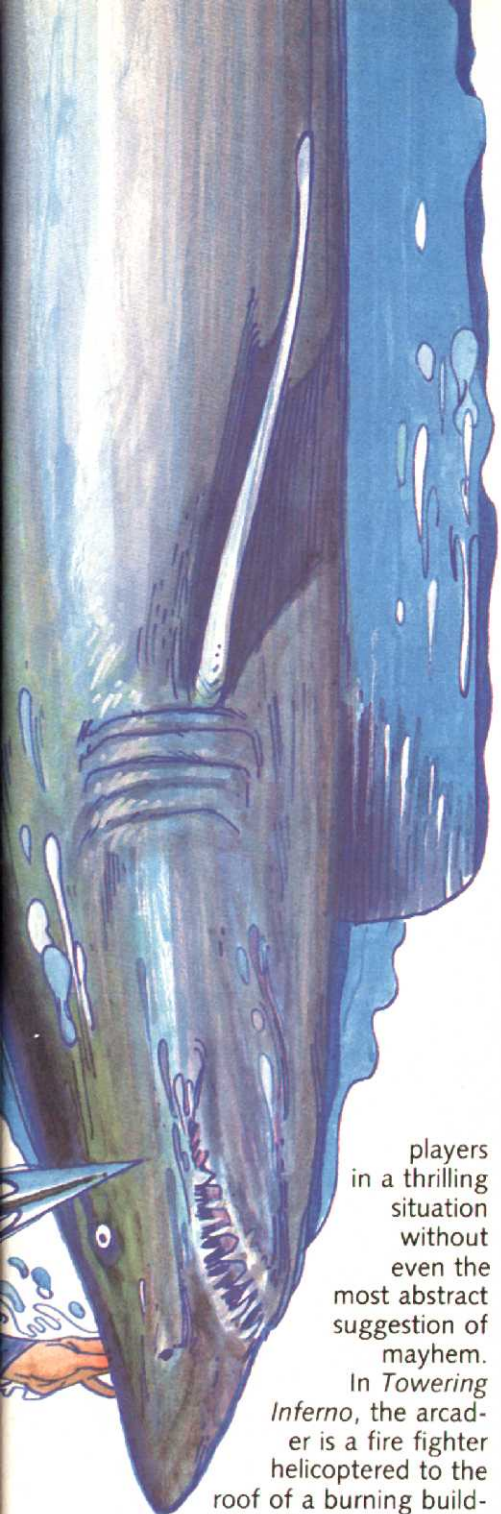

players in a thrilling situation without even the most abstract suggestion of mayhem.

In *Towering Inferno*, the arcader is a fire fighter helicoptered to the

roof of a burning building. Hose in hand, the fire fighter must work

top floor, fighting and dodging the flames, to rescue the survivors. There are four people trapped at the top of the screen in each round, but they are overcome by the smoke one by one as the game's clock ticks off precious seconds. The faster the gamer moves the on-screen character, the more people can be saved from a hideous flaming death.

The hose can spray a stream of water in the direction in which the nozzle is facing—either toward the top or bottom of the screen—by hitting the

# STICK IT!



Play on the Atari<sup>®</sup> 2600 Video Computer System<sup>™</sup> and Sears Tele-Game<sup>®</sup> Video Arcade<sup>®</sup>

When it comes to video games, there's nothing else like a game by Telesys. Nothing whackier. And nothing more challenging.

Eating little white dots is pretty bland, compared to munching the flying burgers, shakes and fries in *Fast Food*. It's a furious feast!

Keep Stanley I. Presume hot-footing it as he dodges Coco's barrage of nuts in *Coco Nuts*. But don't laugh—this is serious business. It's a knock out!

And try *Cosmic Creeps*—a space game that's out of this world. It's up to you to save the Cosmic Kids from Skeeters, Creeps and oblivion. It's a blast!

Stick it, with Telesys video games. You'll be stuck on them for good.

**Telesys**<sup>™</sup>  
**FUN IN GAMES.**

43334 Bryant Street, Fremont, CA 94539

Atari and Video Computer System are trademarks of Atari, Inc. Tele-Game and Video Arcade are trademarks of Sears, Roebuck and Company.







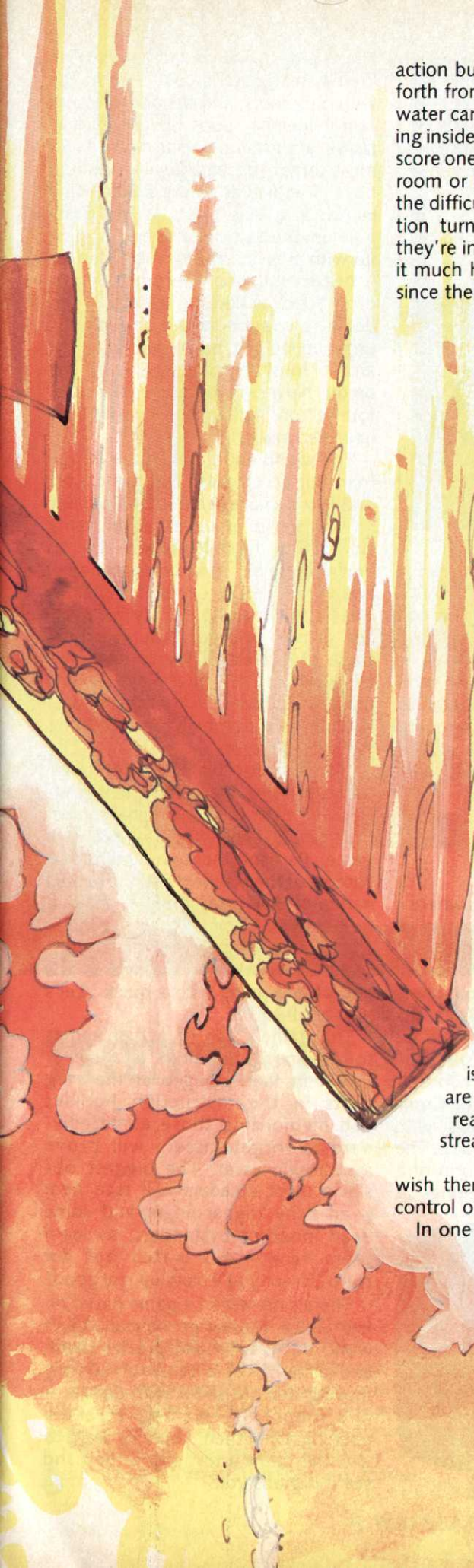

action button. Flames move back and forth from left to right. No amount of water can put out a flame that's burning inside a wall, but the fire fighter can score one point for dousing a flame in a room or hallway. (Note: Playing with the difficulty switches in the "A" position turns the flames invisible when they're in one of the walls. This makes it much harder to plan hose strategy, since there's much less warning when

the line of fire approaches your character.)

The heavy point values, though, come from saving victims of the fire, so this must be the goal of anyone hoping to do really well at this cartridge.

Once the fire fighter threads a path up the playfield to where the survivors are waiting for help, he must turn around and lead them back down the screen toward the safety of the waiting helicopter. The whirlybird carries them off, and the fire fighter begins again on another floor. Play continues until either the whole building is under control or the player loses all three of his men. Of course, if you take too long, some floors already visited may burst into flames again, but that's the breaks in the heroic game of fire fighting.

Like most cartridges for the VCS, *Towering Inferno* is stronger in action than its visual effects. The display is all right, though the images are certainly more symbolic than realistic. The water looks like it's streaming from the hose, though more than one player will

wish there was a way to exert finer control over the water.

In one sense, *Towering Inferno* is a victory for those who believe that manufacturers should, indeed, not rely

so much on whizzing bullets to produce on-screen excitement. *Towering Inferno* plays something like a maze-shoot, even though there's not so much as a single bullet fired in anger—even at totally evil alien monsters. Yet this cartridge is about as exciting as any videogame done along more traditional lines.

But let's put all the philosophizing where it belongs—back into the storage cabinet with the unused cartridges. *Towering Inferno*, even apart from its low violence quotient, offers plenty of solid arcading. It's fast, exciting and different enough from the typical cartridge to be of interest to VCS owners. It's a well-done, enjoyable contest.

## LADYBUG

Coleco/ColecoVision

When Coleco went on its coin-op buying spree earlier in the year to collect a library of recognizable arcade videogames for home translation, Coleco didn't just go after the big fish. True, it picked up several of the year's hottest titles (*Donkey Kong* from Nintendo and the Sega connection that includes *Zaxxon* and *Turbo*), but the company also went after several dark horses, classic contests that never made it big in the arcades, such as Exidy's prophetic coin-op adventure contest, *Venture*.

Another company that has never gotten its just desserts in the coin-op world, Universal, has turned out at least two games that are flat-out brilliant. The earlier, *Space Panic* was almost certainly the first arcade "climbing" game and has done fabulously well as a piece of Broderbund-produced Apple software, retitled *Apple Panic*.

*Ladybug*, although bearing more than a slight similarity to other maze-chase videogames that have passed this way before, is uncontestedly the most valid variation on the theme since *Pac-Man*. What *Ladybug* does to the classic format is to turn it into a game of fast-reflexes and an even keener, strategically-oriented mind. The object of the game is for the player-controlled lady-insects to gobble the asterisk-like dots that fill this ever-shifting maze, gulp down the bonus items and avoid the poisonous skulls which appear in greater numbers each rack around.

The enemy consists of several



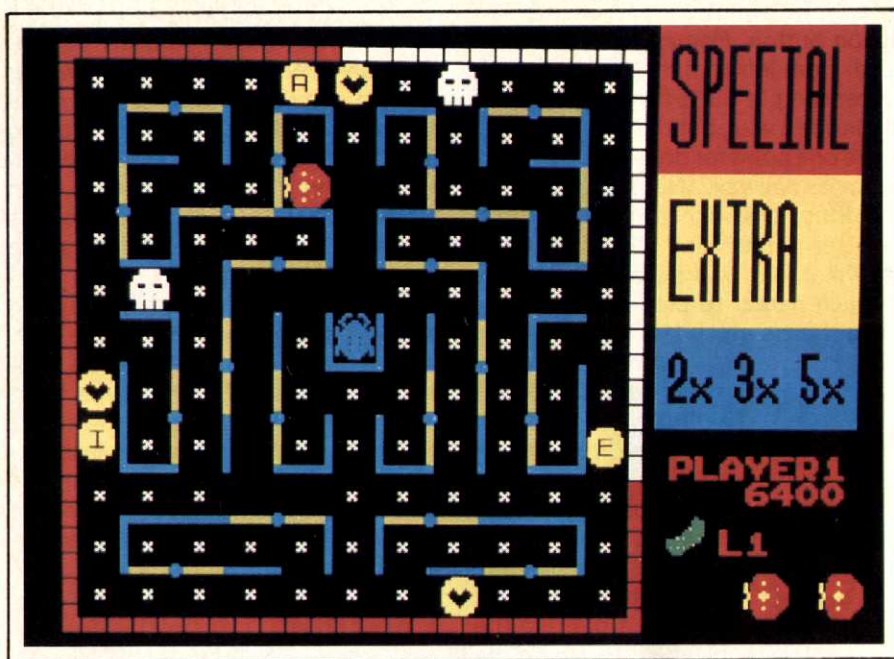

LADYBUG

species of nasty insect-life, from wasps to hungry beetles, all guarding—and emerging from—a tiny vegetable garden at the center of the screen, where each round presents a new, leafy bonus treat for your ravenous ladybugs. Four enemy bugs emerge from the garden each time a flashing light makes a complete revolution around the playfield. The poisonous skulls can also kill the hunter-insects, and there is no "energy dot", a long-overused maze-chase convention. The Ladybug is strictly on her own, with only your quick wits to save the day.

Here's the rub: the playfield includes not only maze corridors but also revolving, turnstile-like doorways, which only the ladybug can move. Skillful use of these turnstiles can trap the hunters, keep them at bay or backfire on the she-bug—even the best laid plans of arcaders and insects occasionally go astray, after all.

It's the turnstiles, and the bonus-veggie that make *Ladybug* so addictive. Snatching up that green goodie even freezes the hunter insects in their tracks momentarily, giving your ladybug a chance for a strategic retreat to safer quarters.

How does the ColecoVision version stack up against the original? Hey, boys and girls, this is no shabby home-clone but a virtually perfect recreation of the Universal coin-op. The graphics are superb—as good as anything in the ColecoVision line so far with the exception of the unbelievable Smurf title, *Escape from Gargamel's Castle* (which is only the most incredi-

ble bit of computer animation you've ever seen on a home TV). The sound effects are picture-perfect coin-op match-ups.

How does ColecoVision do it? Who cares—as long as they continue to produce rave-ups like this, rescuing abandoned classics from the arcade dust bin. An unqualified, glassy-eyed recommendation.

Take a bow, folks.

## GANGSTER ALLEY

*Spectravision/NCS*

Ever see those police shows where a rookie is put through his paces in an artificial environment whereupon cardboard images of criminals as well as innocent bystanders pop up at doors and windows? Points are collected by hitting the baddies and subtracted for firing at the everyday citizens.

*Gangster Alley* takes that concept, mixes in elements from *Missile Command* and *Kaboom!* and winds up with an interesting idea that lacks juice. The playfield is designed in the form of a building with numerous openings at



GANGSTER ALLEY

which a cluster of criminals, identified in the instruction booklet complete with mug shots, and the odd innocent family member pops up periodically. Using a sighting cursor, the player must target the bad guy—once he's been identified as a non-civilian—and launch a quickie blast. As the game goes on, the participants begin turning up with ever-increasing regularity.

Just so you won't become complacent, Spectravision has a joker in this deck—a mad bomber periodically turns up on the building's roof. The arcader must immediately draw a bead on this blow-up artist and zap him before he hurls his flaming explosive (and he *never* misses).

The sound and graphics are pedestrian but acceptable. The game's big problem is a failing shared by too many of the hoard of videogames being stuffed into the marketplace—the "is that all there is?" syndrome (otherwise known as Peggy Lee's Complaint). After a few minutes of play the average arcader will go through a brief stage of interest in the contest's intriguing and unique play. This is quickly followed by a shrug and another cartridge being inserted into the old 2600 slot.

Please don't misunderstand. *Gangster Alley* is a commendable effort, and attempt at an original contest that should have made an excellent game. Perhaps the two-dimensional flatness of the playfield and the limited nature of play is responsible, but that well-known "replay" button possessed by each videogamer's never pressed. Players will not respond to the end of one game with a quick "Let's play another!"

The game's use of actual names for the peeping felons is a clever touch. In fact, going over the mug shots in the instruction booklet and memorizing those admittedly-hard-to-forget kissers will prove a strategic asset. The biggest obstacle most arcaders will face here is an itchy trigger-finger and some dead innocent bystanders, so learn them faces—and watch out for Nitro Ed—or you'll blow up real good!

There's no reason a game based on the police test-range concept can't work, but it will need greater depth and dimensions, a sense of actually moving down a street with danger—and innocents—waiting at every opening. Until then, you may want to give this game a test play or two and see if it grabs you.





## NEW ATARI® REALSPORTS.™ THEY'RE IN A LEAGUE BY THEMSELVES.



**VOLLEYBALL**



**FOOTBALL**

These pictures show you how incredibly life-like new ATARI RealSports video games look.

What they can't show is even more exciting.

RealSports action. Players who move like real players. Sinker balls, long bombs, spikes, and saves. The whole ballgame.

Plus the challenge of mastering a video game that plays so like the real game.

And unlike some video games, RealSports lets you play the option: to play alone against the computer, as well as against another person.

There is even a bonus for rookies. A coupon worth \$2.00 toward your next RealSports purchase when you buy ATARI RealSports Baseball, Volleyball, or Football\*.

For a tryout, see your Atari dealer today.

**ATARI**

**A Warner Communications Company**



# Ultravision™

## a Leader in Innovative and Entertaining Alternatives Presents...



The Latest In Arcade Quality  
Video Games For Use With The  
Atari® Video Computer System™

Mankind's Last Stand Against The Planet's  
Greatest Enemy... The Ferocious And  
Invincible Amazon Condor... A Deadly  
Killer!

### CONDOR ATTACK™

A MARTIAL ARTS Contest to  
Determine The World's Greatest  
Champion!... If You Think You Are  
Good Enough... Test Your Skill  
Against The Computer Or Another  
Opponent... And watch Your Skill  
Level Increase Right Before Your  
Eyes!



### KARATE™

**\* CONSUMER SATISFACTION GUARANTEED \***

VIDEO ARCADE SYSTEM CARTRIDGES ARE  
THE MOST ADVANCED IN THE "STATE OF  
THE ART" VIDEO PROGRAMMING. THEY  
WILL EXCITE YOU WITH THEIR SPECIAL

EFFECTS: TEST YOUR SKILLS AND  
CHALLENGE YOUR POWERS OF  
CONCENTRATION!

©1982 Ultravision®. All rights reserved

**COMING SOON!... Quest For The Idol™ & Spider Kong™!**

ULTRAVISION, INC. 2315 N.W. 107th Ave., Miami Free Zone (Box 19) - Miami, Florida 33172  
(305) 592-0878 Telex 80-8344

Also for use with Sears Tele-Game®, Atari® and Video Computer System™ are trademarks of Atari, Inc. Sears and Telegames® is a trademark of Sears, Roebuck & Co.



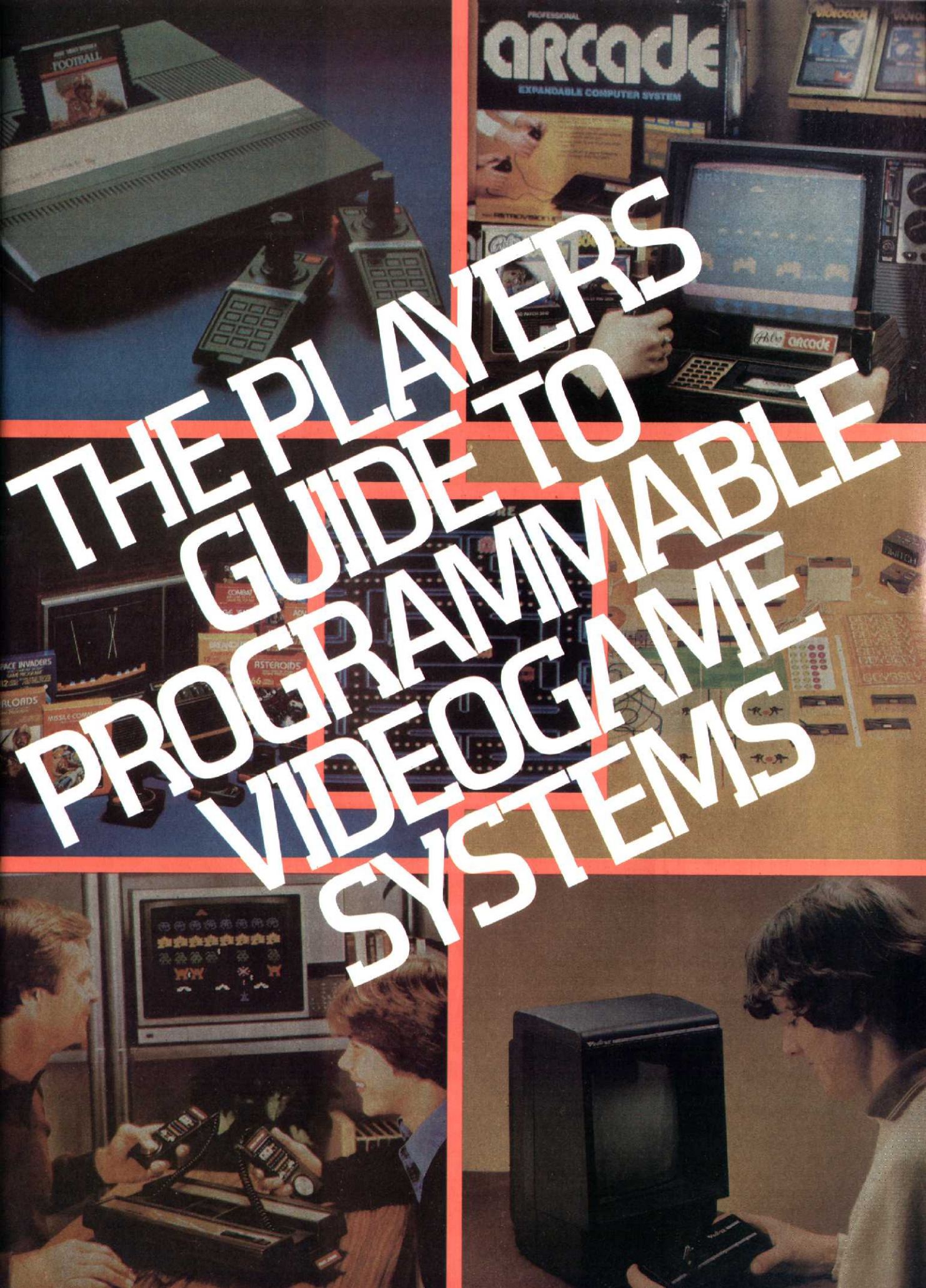

# THE PLAYERS GUIDE TO PROGRAMMABLE VIDEOGAME SYSTEMS



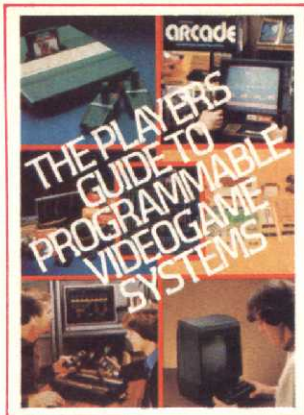

# ATARI

## VCS HARDWARE

The Video Computer System (VCS) has become the subject of an increasing amount of debate among electronic gaming enthusiasts of late. Its staunch defenders champion the VCS as the greatest of all the home fun machines. Detractors snipe back that it's a technological relic, an outmoded system that ought to be collecting dust in a closet somewhere.

Yet even amid the din of rising voices, one simple truth remains inescapable. There's no denying it: The Atari VCS is far and away, the most popular home arcade system in the world today. There are more VCS units in use right now than all other brands combined. Software is the same story, thanks to a slew of companies that have jumped at the chance to cater to the huge audience of VCS owners.

Developed in 1978, the VCS—soon to be officially renamed the 2600 by the manufacturer—is a standard programmable videogame system. That means it has low-resolution graphics, a small amount of screen RAM (used to move objects around the display, among other things) and 4K bytes of resident memory. Interestingly, the VCS might've had only 4K of memory on board if hardware designers hadn't convinced the company that it was worthwhile building in the extra capability, even if it wasn't going to be used immediately.

The VCS is ruggedly constructed to withstand anything short of intentional vandalism. Apart from the cartridge slot, the only major feature on the otherwise

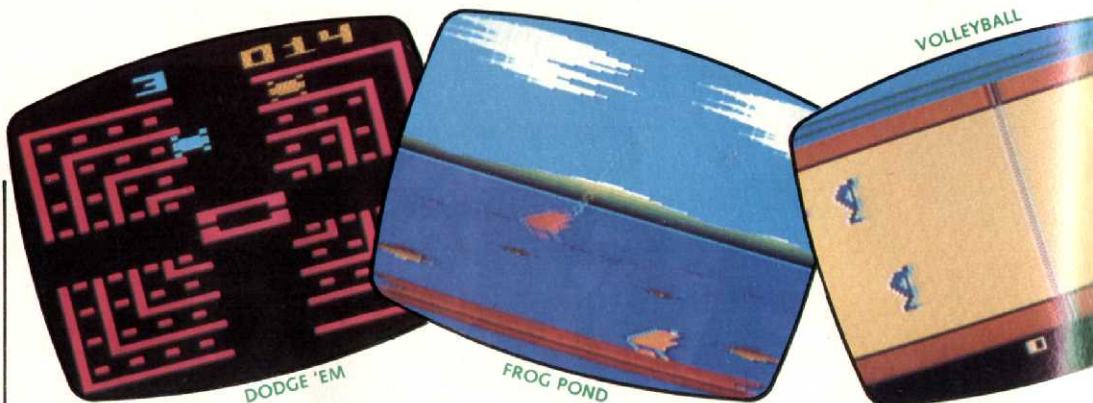

plain-looking console is a front panel with an array of four vertically moveable slide switches. Grouped in pairs on each side of the slot, these controls govern (from left to right): on/off, color/black & white, game select and game reset.

Older units actually have six slide switches on the front panel. The extra set is a pair of left and right difficulty controls, which have been moved to the back panel next to the game ports. While this makes the difficulty levers a little less convenient on the latest machines, it does prevent ac-

cidental mis-setting during play sessions.

Each VCS is packaged with a pair of paddles and a set of two joysticks. With a few exceptions, these are sufficient to play most VCS cartridges. *Indy 500*, a race game, comes with its own special steering controller and several titles utilizing keypad controllers that must be bought separately. (Atari will shortly introduce yet another controller for use with the VCS edition of *Star Raiders*.) All control devices connect to the back of the console with 9-pin plugs.

The eight-position joystick

is an industry standard. The narrow base is small enough to accommodate all but the smallest hands, and the long shaft provides good leverage. The paddles are satisfactory, if not exceptional.

## THE VCS SOFTWARE EXPLOSION

Whatever ivory tower technicians may say, it is impossible to view the VCS as anything but very much alive as long as a dozen or so cartridges reach stores each month. Atari offers over 50 cartridges for the system





# VCS: The Most Popular System

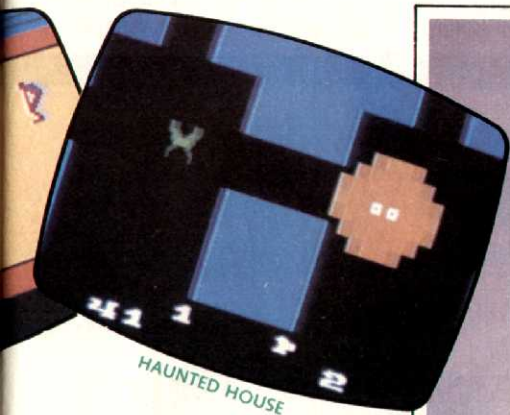

under its own label, and more than 15 independent producers are fielding VCS-compatible cartridge libraries of their own.

Some of the best games include (manufacturers' names are in parentheses):

**Berzerk (Atari).** Clever programming makes this an excellent home version of Stern's much-loved coin-op maze-shoot. The player must shoot his way through a series of rooms populated by hostile robots.

**Defender (Atari).** Another hot commercial arcade game that fares well on the VCS is



VCS SUPERCHARGER AND WICO JOYSTICK

this Williams-designed scrolling shoot-out. The action is virtually non-stop, and the graphics are surprisingly good.

**Demon Attack (Imagic).** Smooth graphics, multiple menaces and attractive appearance make this one of the very best of all the invasion-type contests. Particularly nice is the fact that some attackers split into two smaller enemies after taking an initial hit from the player's cannon.

**Star Master (Activision).** It's you against a galaxy full of ravaging aliens in this space piloting game. This science fiction tour de force boasts both strategic and tactical display screens.

**Tennis (Activision).** Sports games aren't really a prime

strength for the VCS, but this clever net cartridge is one of a handful of happy exceptions. The best visual bit is that the ball casts a moving shadow in flight, making it easier to follow its trajectory and line up shots.

**Donkey Kong (Coleco).** This two-screen version of the Nintendo coin-op captures much of the flavor of this climbing game. Help Mario get to the top and release his girlfriend from the dreaded giant gorilla.

**Football (Mattel).** This M-Network title fills a yawning gap in the VCS line. Skip Atari's pigskin cartridge in favor of this one.

**Space Cavern (Games By Apollo).** You're a space suited

figure standing on the floor of a huge cavern on the mysterious planet on which you've just landed. You must use your laser rifle to battle flying monsters from above, and shaggy ones that rush at you from the side.

**Commando Raid (U.S. Games).** You're in charge of an anti-aircraft gun with the job of keeping the paratroopers, dropped by swarming enemy helicopters, from destroying your installation.

**Frogger (Parker Brothers).** No VCS-compatible cartridge has better sound than this one, and the action is nothing to sneeze at, either. Steer your frog across the road and river to a safe haven, but beware of those sneaky diving turtles!

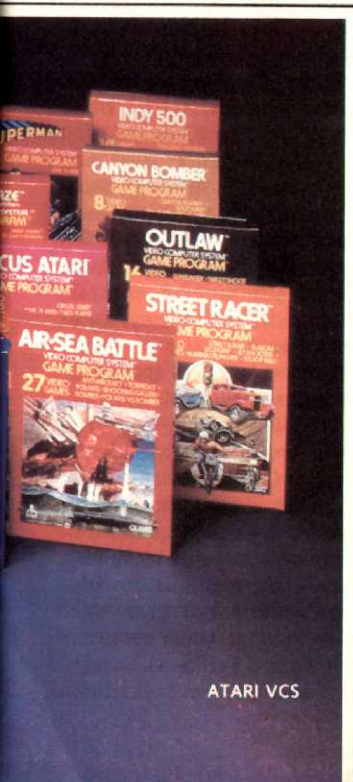

ATARI VCS

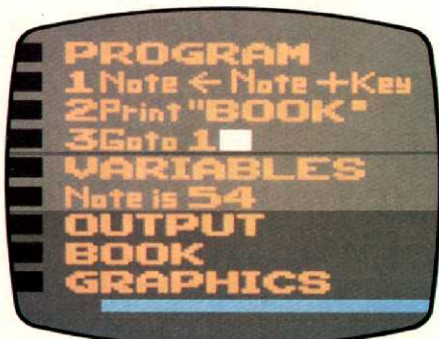

BASIC

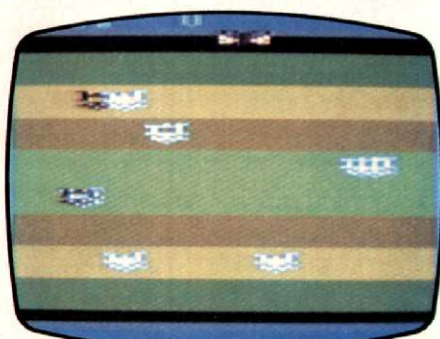

DEMONS TO DIAMONDS



## SUPERCHARGER: NEW LIFE FOR THE VCS

The biggest complaint against the VCS, even by those who love the system, is its low-resolution graphics. Enter the Arcadia Supercharger, a device that gives this popular machine exactly the shot in the arm it needs.

The Supercharger is something new under the VCS sun, a RAM cartridge. It plugs into the regular slot and then attaches to any cassette record via a cable. Games on tape can then be entered into the VCS for playing through the Supercharger cartridge.

What it does, basically, is increase the amount of screen

RAM available to the VCS. That means that Supercharger games can have more objects in motion on the screen and render images with more detail than is possible in the ordinary 4K cartridge.

Those with some computer experience may blanch at the thought of connecting their VCS to a tape-based system.

Fortunately, the Supercharger enters data so rapidly that loading takes only a few seconds, rather than the 10 minutes or so that is required to load some taped Apple II games.

The Supercharger is list priced at approximately \$80 and comes with a **Phaser Patrol** cassette. Future releases

# ODYSSEY<sup>2</sup>: The

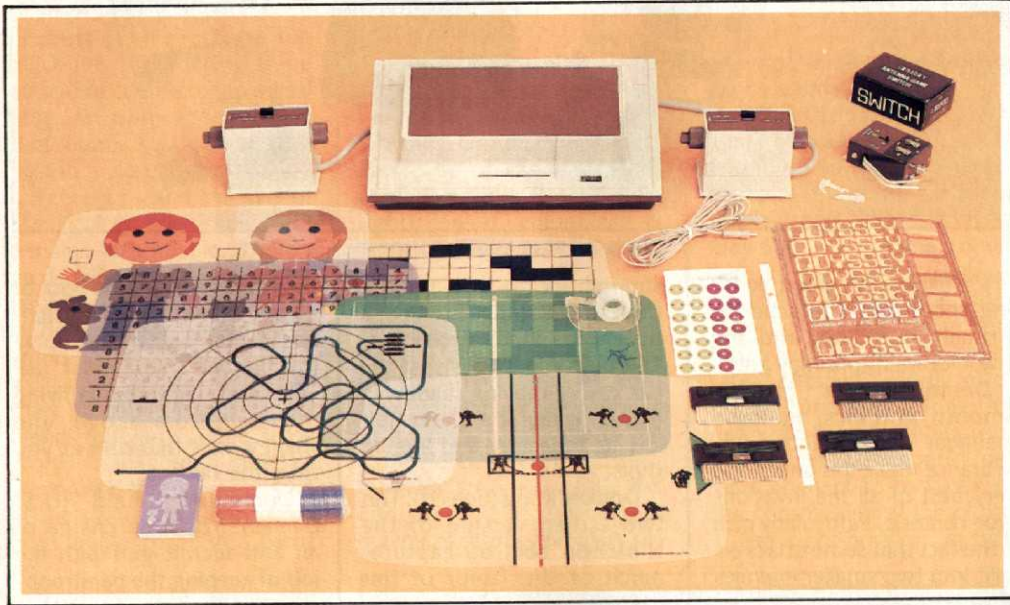

ORIGINAL ODYSSEY

## A FLEXIBLE HARDWARE SYSTEM

Odyssey is the oldest name in programmable videogame systems for the home, having marketed its first system about

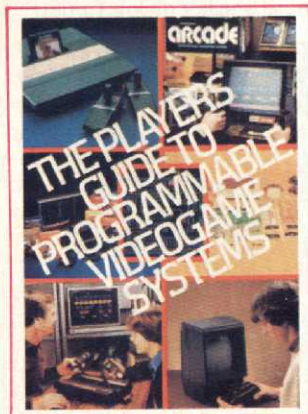

a decade ago. Unfortunately, inventors Ralph Baer and Sanders Associates had to use the crude computer technology of that period in creating their machine.

The old Odyssey was something like a dancing dog. It was incredible that it played such a variety of games, even if the games themselves didn't do much to fire the imagination.

Let's just say this early experience didn't go for nothing. It consistently shows up in the company's current videogame machine, the Odyssey<sup>2</sup>.

This standard programmable videogame's main advantage is its full membrane-type keyboard. It allows the possibility for a much wider variety of input from the players than

is possible with a system exclusively based on joysticks. True, Odyssey didn't make much use of this feature during the first couple of years the O<sup>2</sup> was on the market, but the company saw the error of its ways in 1981 and introduced the keyboard-based Master Strategy Series.

Except for the keyboard, the Odyssey<sup>2</sup> console is simplicity itself. The flat silver-finished unit has a large red on/off button, a cartridge slot and a pair of joysticks wired into the machine. (Handy gamers can detach a defective controller by opening the machine.)

The action button on the joystick mixes good news with bad. They're large and comfy, but do exhibit a tendency to

break down when the gaming action reaches critical mass.

Wiring the controllers into the console does eliminate the problem of plug breakage, but it also creates a serious limitation. The joystick must be used for all cartridges, even those which, like **Blockout/Breakdown**, would be more fun to play with a paddle.

## ARCADE-STYLE SOFTWARE

The Odyssey<sup>2</sup> is known as the family system because its software library, though not nearly as large as some other systems' catalogs, is unusually diverse. Whether you prefer shoot-outs or sports, battle games or board games, there's likely to be something available you'll enjoy.

Now, the flip side to this particular coin is that there aren't too many cartridges in any one category. If all you want is sports and then some more sports, you may well want to seek elsewhere. On the other hand, those who have wide-ranging interests may find the Odyssey<sup>2</sup> most attractive.

Some good bets among O<sup>2</sup> cartridges include:

**UFO (Odyssey)**. This is not only the best game in the whole Odyssey catalog of software, it's one of the most compelling action games produced for any home system. You're the commander of a highly mobile saucer charged with ridding your sector of space from hunter-killer satellites and enemy faster-than-



such as **Communist Mutants from Outer Space** will cost about \$15 each.

## CUSTOM CONTROLLERS

With the standard Atari 2600 joystick becoming the most commonly-used controller in the videogame universe, it has become the basis

for an array of adaptations and additions culminating in a virtual industry. Joystick stands, console type controllers and deluxe joysticks are sprouting like mushrooms.

Currently leading the parade of companies with super controllers is the Chicago's WICO, already a producer of coin-op con-

trols. Their new joystick is a heavily based controller with both side and top-mounted action buttons. WICO also looks to be the first company to get a trac-ball controller onto the market. The tracball is fluid and highly responsive and more controllers for alternate systems are on the way.

Discwasher, meanwhile,

has a beautifully hand-molded action/fire button and Computability has two joystick models, the Starfighter and the lower-priced Slik Stik, both available for under \$20 each.

Fans of button/console controllers can look at either the Starplex or B.C. Controllers, each retailing at \$29.95.

# Family System



SUBCHASE

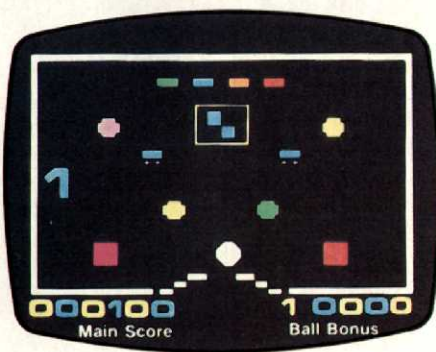

THUNDERBALL



INVADERS FROM HYPERSPACE

light patrol craft. The cartridge is especially good for those who don't like long, multi-round games; you'll be lucky to stay with this one for more than five minutes before your saucer turns into space debris.

**Baseball** (*Odyssey*). This is a surprisingly detailed electronic version of the national pastime for two players. Pitching, hitting and fielding all play a part, and the various aspects of the game are woven together quite effectively.

**Blockout/Breakdown** (*Odyssey*<sup>2</sup>). Despite having to be controlled with a joystick instead of a paddle, this is a pretty good wall-bashing (and building) game for one or two players. A nice touch is that the computer is willing to handle either side in solitaire games.

**War of Nerves** (*Odyssey*). The unique control system which lets the gamer move an entire army of robots at the same time, is the prime ingredient in creating one of the best video war games ever to be published. Two laser-

equipped armies square off against each other and fight on fields with lots of terrain features.

**Football** (*Odyssey*). The lack of a scrolling playfield is certain to annoy purists, but this arcade-style pigskin cartridge will surely entertain those who are less than fanatical football buffs. The offense can run and pass, while the defense has the job of rushing the passer and shadowing deep receivers.

**Pick Axe Pete** (*Odyssey*). This climbing contest takes you deep into the mines in an exciting hunt for gold. The graphics, though a little sparse, are quite attractive and engaging.

## THE MASTER STRATEGY SERIES

Memory limitation has proven to be one of the worst problems facing any designer of videogame software. The

folks at Odyssey came up with a novel way of getting around this roadblock: They created a series of games which transfer some of the burden for record-keeping and so forth to the human participants, leaving the O<sup>2</sup> to take care of the action elements.

The sumptuously packaged Master Strategy Series of videogame/boardgame hybrids provides gamers with an opportunity to enjoy an unusually rich gaming experience. The individual titles may well be beyond the youngest Odyssey fans, but more mature ones may well find that these contests are their favorites.

Currently available are:

**Quest for the Rings.** This is a fantasy adventure for two participants acting as a team. Each character has a special power, such as the ability to turn invisible or throw magic spells, to aid him in capturing the 10 magic rings.

**Conquest of the World.** Global power politics are the subject of this military-tinged simulation. Skillful planning,

ODYSSEY<sup>2</sup> AND SOUND MODULE





good timing and an occasional show of force can make your home country into a world-class power.

**The Great Wall Street Fortune Hunt.** Whether you're an

actual investor or just someone attracted by the glamor and money of the stock exchange, this money game will provide a stern test of your financial instincts. One or more

would-be Rockefellers can buy, sell and trade an array of securities.

A prime feature is a display that includes a scrolling stock ticker and newswire.

## THE ODYSSEY<sup>2</sup> SPEAKS

Sometime during the first half of 1983, an extra dimension will soon be added to the Odyssey<sup>2</sup> videogame

# MATTEL

## SUPER GRAPHICS GALORE

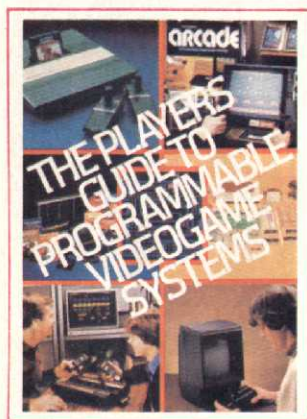

### MATTEL'S MODULAR HARDWARE

Mattel announced the Intellivision, amid a flood of publicity in 1981, as the harbinger of the world of home computers to come. It was projected as a modular system that would begin with the videogame-oriented Master Component and then, through the addition of various modules, be expandable into a full-fledged computer.

The catalog was bright with promise, but this ambitious plan somehow never got untracked. Only the Master Component has entered into national distribution. The

keyboard has been mired in test market for a couple of years, and only an optimist would expect to see it soon.

Does that make the Intellivision a failure? Not to the more than two million videogamers who own Master Components. They're too busy having fun with the system's rapidly expanding software collection to worry much about a computer that probably would've been something less than state-of-the-art by the time it all came to market, anyway.

The Intellivision as it stands is a senior programmable videogame system. It has high-resolution graphics, roughly 8K of resident memory and significantly more screen RAM (used to move objects around the playfield). In plain English, this means that the images in an Intellivision game look better than those in a standard system cartridge, and more items can be in motion simultaneously than is possible with hardware possessing less screen RAM.

### INTELLIVISION



So far, so good. The hitch is that movement speed is somewhat slower in Intellivision games than it is in games that mate with other systems. This is barely noticeable in most of the sports simulations, but it is very much a factor in action-oriented contests.

The design of the Intellivision controller magnifies this problem. The command devices, hard-wired into the system on coil cords, each have a monoplanar (flat) keypad, a pair of action buttons mounted on each edge and the controversial direction disc. Though the disc certainly has its supporters, many arcaders find it frustrating to use the disc to steer in games which require rapid changes in direction.

One feature of the Master Component that may come in handy is that cartridges are plugged in on the right side rather than loading from the top. Since the controllers fit into niches that allow them to





system—a speech synthesizer. Usable with a special line of voice cartridges, this device plugs into the console's slot and, in turn, accepts the usual ROM cart.

Instead of just a few beeps and boops, the O<sup>2</sup> voice games will feature actual speech. Although a unit was not available for exhaustive testing for this players guide, a

special demonstration of the unit's capabilities was very impressive. The speech is sharp, clear and easily understandable, which should also greatly enhance play.

The first of the cartridges to utilize the voice synthesizer is **K.C.'s Crazy Chase**. The game plays without the Voice unit, but obviously, is even better with it.

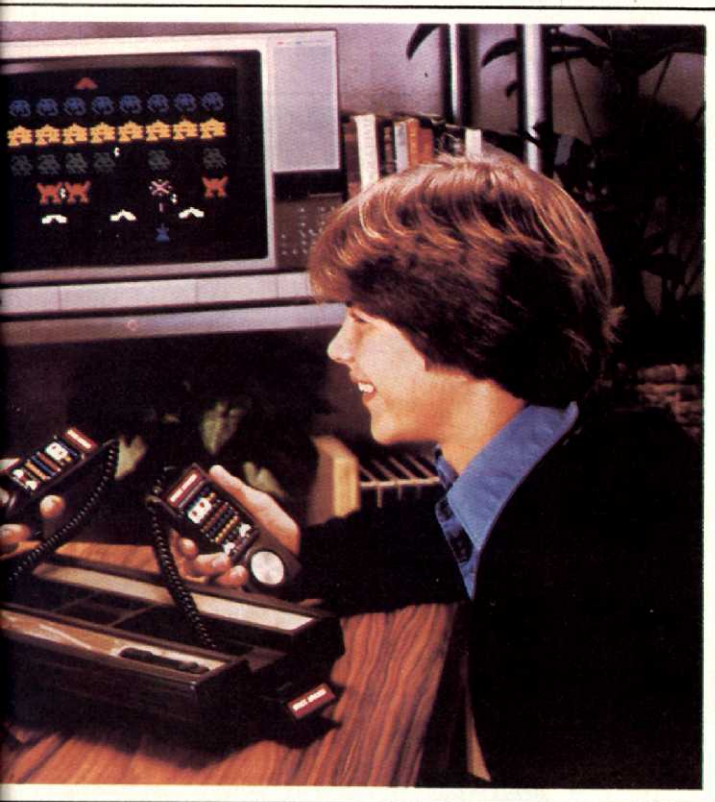

lie flush with the top of the console, the Intellivision can be stored on a much skinnier shelf than some of the other machines—and it doesn't need appreciably more "head room" when it's actually in operation.

## SUPERB SPORTS SIMULATIONS

With the exception of professional wrestling, just about every team or individual sport worth mentioning has found its way into the Intellivision

cartridge lineup. No videogaming system—or home computer, for that matter—at any price offers sports cartridges in such quality and quantity.

Some (of the many) superior cartridges include:

**Major League Baseball.** Two managers can match wits in the most comprehensive baseball action game ever created. Pitching and batting are satisfyingly detailed, and no electronic version of the national pastime has a more

fully realized fielding component. Keypad input allows for individual control of every fielder on all plays.

**NFL Football.** The only possible rap against this one is that it is such a realistic simulation of gridiron thrills that it may be too complex for those who aren't fairly knowledgeable about the real-life sport. The selection of available formations and plays is awesome.

**USAC Auto Racing.** This is a rarity among the sports games in that it can be played solitaire as well as head-to-head. Multiple courses of varying difficulty as well as a choice of cars makes it easy to pick a variation that's appropriate to the player's skill level.

**NASL Soccer.** Although there are only three men from each team on the screen at a time, the scrolling playfield permits realistic play-making and passing since you can boot the ball to off-screen teammates.

**NBA Basketball.** This is easily the best hoop cartridge available today. Clever use of the overlays makes it simple to work the ball around the court and set up a high-percentage shot.

## NON-SPORTS SOFTWARE

It would be a gross oversimplification to say that the only good Intellivision cartridges are the sports games. While the systems' software designers haven't fared quite



as well with action games, there are a few well worth considering. A recent development which has improved the situation is that cartridges from independent publishers are now reaching stores for the first time, expanding the selection of titles.

Some of the most exciting titles (manufacturers' names in parentheses) are:

**Space Battle (Mattel).** This interstellar combat game combines tactics and strategy by offering two distinct playfields. In this solitaire game, the commander dispatches three squadrons to deal with enemy fleets streaking toward his mother ship. When the rival forces meet in space, switching to the battle display allows the player to take command of a space fighter and deal with the menace personally.

**Night Stalker (Mattel).** This is an intriguing maze-shoot-out that is only slightly marred by an inappropriate control scheme. You must use all your

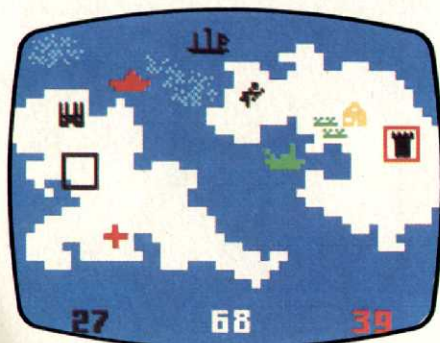

UTOPIA

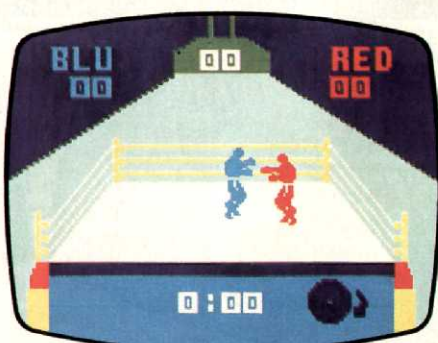

BOXING



ROYAL DEALER



wits to avoid the increasingly deadly robot attackers.

**Demon Attack** (*Imagic*). In many ways this can be considered a deluxe edition of the game that won the hearts of VCS players across the country. Slick graphics highlight this fast-moving invasion-style game.

**Armor Battle** (*Mattel*). Forget all previous tank combat games, this is the one. Each team has two armored vehicles and can switch back and forth between them at will. The terrain, seen in overhead perspective, is both varied and detailed.

## WORDS TO PLAY BY

Voice modules are turning up all over, but Intellivision has the distinct advantage of being the first out of the gate. Their Intellivoice module plugs directly into the cartridge slot of the Master Component and special, non-compatible voice videogames are, in turn, slipped into the voice module.

The earliest releases for this new line include **Space Spartans**, a jazzed-up, revamped version of the early classic **Space Battle**, complete with words to live by from command center—male and female voices alternating, but randomly—giving constant updates on bases and on-board equipment, and **B-17 Bomber**.

## COPING WITH INTELLIVISION CONTROLLERS

While hailed as a great innovation at the time of their introduction, the Intellivision hybrid keypad/disc controller has proven something of a lemon in gaming circles. Especially when engaged in fast action, arcade-type contests, the disc proves both clumsy and painful to manipulate.

In answer to the growing need for a joystick-type adaptor, several bright-eyed inventors have developed ways around the problem. Video Product Sales, for example, has the Injoy-A-Stick, essentially a replacement disc for the controller with a joystick-like shaft attached. Fans of knob-type joysticks, however, might prefer the Skil-Stik from C & T Creations of Providence, RI.

# ASTRO

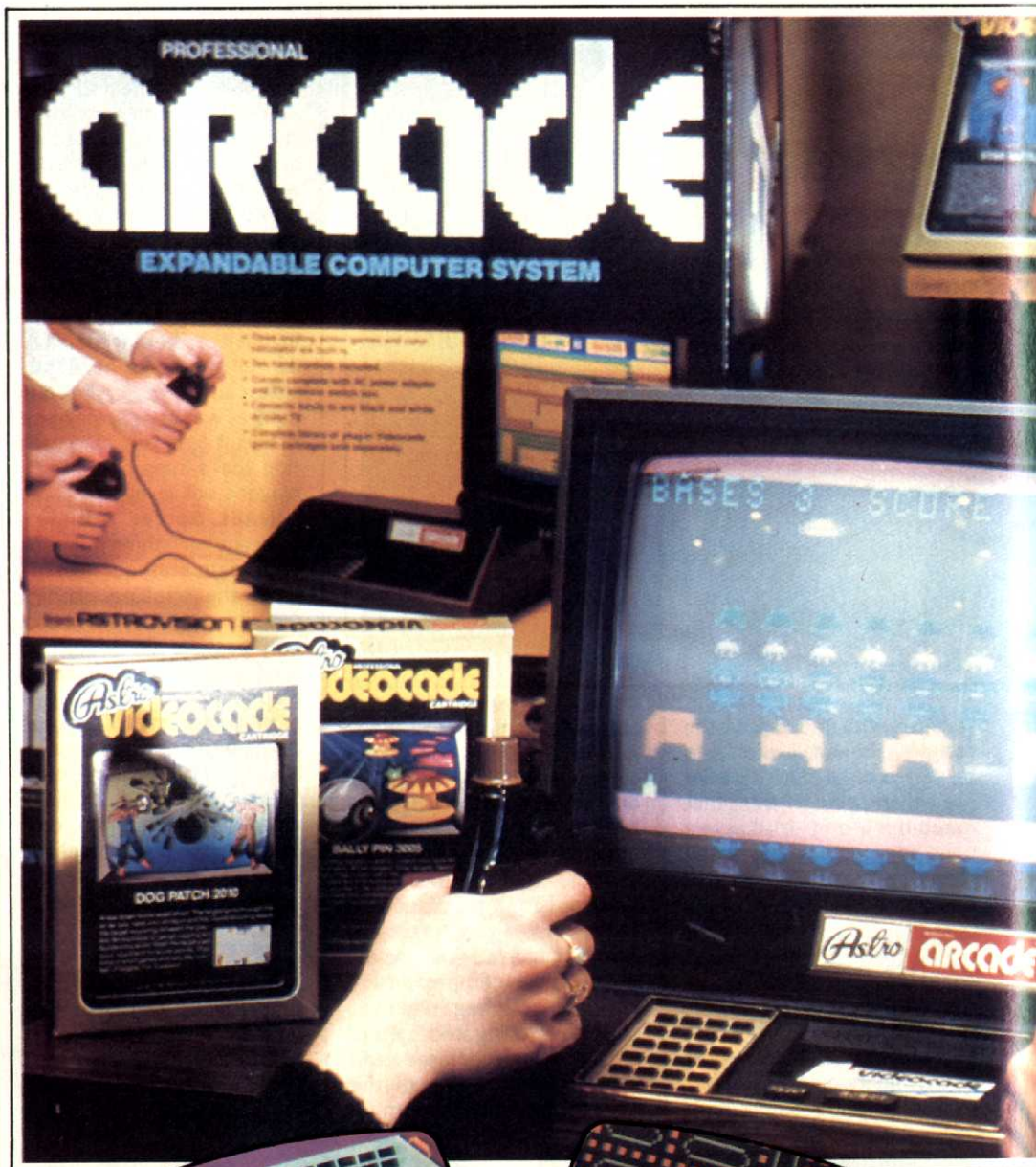

BALLY PIN

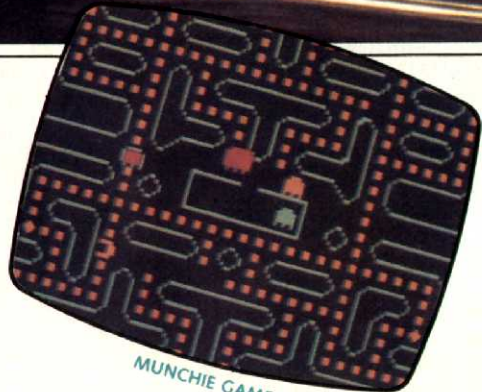

MUNCHIE GAME



# ARCADE: The Big Comeback



## THE STRANGE HISTORY OF ASTROCADE

Before there was a VCS or an Odyssey<sup>2</sup>, the Bally Manufacturing Company introduced a machine under the name, Bally Professional Arcade. The company billed it as a videogame machine with computer-like features that could be upgraded to a full-scale microcomputer through the addition of planned modules such as a keyboard.

This was a fine-sounding plan that never came off. A combination of problems, including a stiff retail price and Bally's lack of experience in marketing consumer products, caused the company to pull in its horns in favor of concentrating on the coin-op business it knows so well.

Yet the system refused to die. User groups filled the void by producing both hardware and software for the machine. It was fairly simple to use the Bally BASIC cartridge to program videogames for the machine, and this resulted in something over 200 games on cassette tape for the system. A couple of suppliers have even brought out keyboards!

The system continued its underground existence until 1981, when a new company called Astrovision acquired the exclusive license to make and market the machine and its software. One quick name change later, and Astrocade, Inc., had the revived Astrocade back in the stores. The company is creating new games, has produced a revised version of the BASIC cartridge and is even getting a ZGrass keyboard ready for introduction in the near future.

## THE HARDWARE SYSTEM

The main features of the

## ASTROCADE



unit's front panel are a cartridge slot, reject button and a calculator-style keypad. The 24 keys can be used to produce full alpha- numerics for home programming, though it's quite arduous to input programs using this keypad.

Many consider the Astrocade controllers to be the best available as standard issue. The gun-grip command device has a paddle, joystick and a trigger, permitting some complicated player-game interaction. The ability to combine the rotational movement of the paddle with the directional movement of the joystick turns games that would be glorified *Pongs* on other systems into genuine electronic simulations found here.

A real plus is that the controllers can be used to select the game, number of players and other variables without need to approach the console. This comes in especially handy if you do your gaming on a giant-screen television set. Too bad there's no remote reset key or any way to insert a cartridge from across a room. Still being able to handle most of the preliminaries using the

controller is a real convenience.

The Astrocade is also unique among current systems in that it provides the bonus of three resident games and a built-in calculator. **Gunfight** is a nifty wild west showdown, **Checkmate** is a line-building contest for up to four players, and **Scribing** is one of the best video drawing programs found this side of the high-end microcomputers.

## ACCESSORIES ADD DIMENSION

As mentioned, those who would like to upgrade their videogame to the status of an

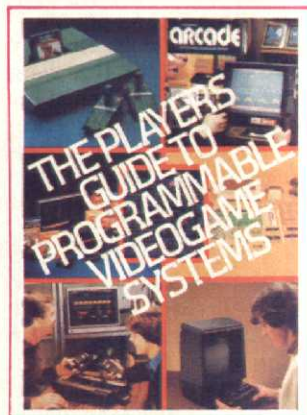



actual personal computer down the road, could do worse than investigate the Astrocade. It is the best bet for such conversion among the four established systems.

Not only is the ZGrass keyboard likely to open computer graphics vistas for would-be programmers, but the Astro BASIC cartridge gives owners a chance to see how they do as amateur game inventors.

## ASTROCADE SOFTWARE

Despite its relatively long life in the market, the Astrocade still suffers from a scarcity of games on ROM cartridges. The best Astrocade programs—**Clowns**, **Red Baron**, **Football**, **Galactic Invasion**, **Space Fortress**, and **The Incredible Wizard**—are strictly first class. Some of the rest of the titles in the

catalog—**Dogpatch** comes to mind immediately—look like a misguided attempt to beef-up the number of titles in the software catalog at the expense of quality.

The user-produced games do improve the situation somewhat. The catch is that they're only available through the mail at this writing. Astrocade has shown some interest in working more closely with its legion of fans,

so they may change in 1983. (Meanwhile, check the January issue of **Electronic Games** for a fuller description of games on cassette.)

Some of the best Astrocade ROM cartridge games are:

**The Incredible Wizard.** Designed by the same man, Bob Ogdon, who worked on the Midway **Wizard of Wor** coin-op, this home version may actually be a slight improvement over the original.

# COLECOVISION: RIDING THE THIRD WAVE

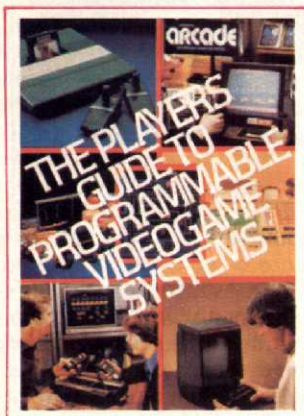

## A HIGH-POWERED SYSTEM

Experienced consumers know that it's rare for a product to actually live up to its advance press clippings. After all, claims are a dime a dozen as long as no one is in a position to test their truthfulness.

So if electronic gamers took a skeptical attitude about ColecoVision during much of 1982, it was only common sense. Now that this third wave system has reached the consuming public, the prevailing verdict is that ColecoVision may well be even *better* than promised.

The system's console features the bare minimum of controls, since game selection and re-start are handled with the controllers. There's an on/off slide switch and a re-set button on the top panel, an interface on the front which

will accept forthcoming ColecoVision modules and two niches for the controllers on the top toward the left-rear.

The controllers feature a doorknob joystick, a mono-planer keypad and a pair of action buttons. The command device is perhaps just a little large for the small-handed to grip comfortably, but should present no serious problem. The joystick is only fair-to-middling, however, and home arcade aces will no doubt look forward to being able to buy some sort of gourmet joystick to enhance play.

## SOFTWARE BRINGS COIN-OPS HOME

The capabilities of the ColecoVision, particularly its 6K-plus bytes of screen-RAM, result in games that look and play better than anything seen on a home system so far. The colors are deep and rich, the images are intricately detailed, and the play-action is most satisfying.

Coleco itself plans to specialize primarily in home editions of games that should be familiar to those who frequent the family fun centers, along with a few adventure and sports titles. It'll be up to third-party software publishers to produce original contests in order to fill out the ColecoVision-compatible catalog. If early sales

momentum for the system holds up, it won't be long before other companies hop on the bandwagon, either.

Meanwhile, ColecoVision owners can revel in such electronic treats as:

**Donkey Kong.** Your girlfriend is the prisoner of a giant ape who has spirited her to the top of a half-completed skyscraper. It's up to you as Mario the heroic maintenance man to scale the ladders and complete the rescue. Three

shows. The object is to leap over the obstacles on the road to Gargamel's castle, where the Smurf hero must save the Smurf-ette.

**Venture.** This home edition may, at last, bring this game the acclaim it has deserved since Exidy introduced it in the commercial arcades. Explore the various rooms, outwit the monsters and snag the prizes. Sound and graphics are straight from the original quarter-copper.

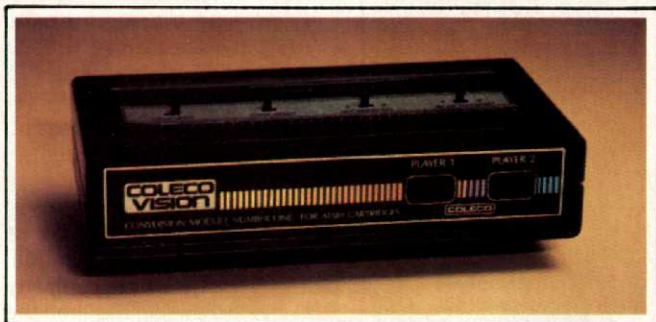

COLECOVISION'S ATARI EMULATOR

screens of action provide lots of variety.

**Cosmic Avenger.** This futuristic scrolling shoot-out puts the gamer in command of an air/sea craft armed with both lasers and bombs. Battle city defenses, UFOs, tanks, submarines and under-sea guns can be found in this fast-paced war game.

**Smurfs.** This adventure game features graphics which can only be compared with Saturday morning cartoon

## THE EMULATORS ARE COMING

Lack of compatibility between various videogame machines has proven a bone in the throat of the electronic gaming hobby. Both Atari and Coleco, however, are taking some steps designed to ease the situation.

Emulators that attach to the ColecoVision and Atari 5200 will soon make it possible for owners of the systems to play cartridges originally designed



One or two players try to keep the mazes free of monsters, some of whom turn invisible and must be tracked on the small radar screen located at the bottom of the display.

**Space Fortress.** The arcade controls the armament of a large space station located smack in the center of the playfield. Aliens approach from the four cardinal directions, firing as they come. The captain of the station must de-

stroy everything in sight before the fortress suffers a deadly collision and blows up with a screen-filling explosion.

**Galactic Invasion.** This home version of Midway's **Galaxian** coin-op features nine different levels of skill, and the action can become pretty intense at upper difficulty settings. Your job: wipe out the swooping aliens before they blast your ship to atoms.

**Clowns/Brickyard.** Talk about "best buys"! This cartridge includes a pair of programs that could easily have been sold separately. One's a wall-bashing contest, while the other involves bouncing a pair of clowns on a teeter-totter so that they sail up to the top portion of the playfield and break the balloons floating there.

**Football.** This sports simulation offers enough scope to

satisfy serious football thinkers, but the control scheme is so beautifully constructed that it is pretty simple to learn even for those who don't live and die by what happens on the nation's gridirons.

**Red Baron.** Fight in the skies with this air-war game. Nice rendering of the planes makes it a pleasure to look at as well as to play.

Several new games will be made available soon.

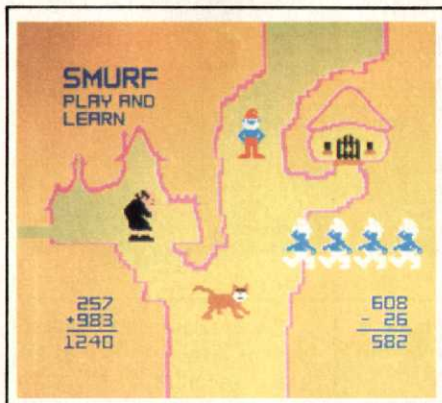

SMURF PLAY AND LEARN

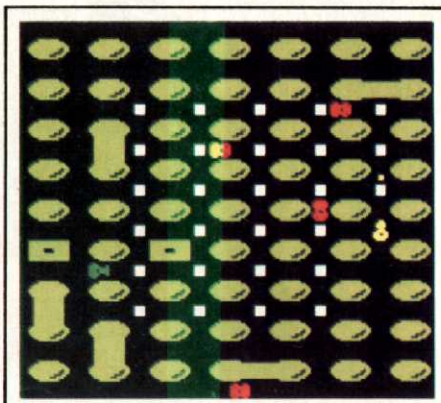

SPECTAR



HORSE RACING

for the VCS. It won't improve the games any, of course, but this will make it possible for all owners of the Video Com-

puter System to upgrade their home arcade equipment without sacrificing the investment they've already

made in cartridges for their present machine.

As with all hobbyists, there is a natural inclination to want

to "trade up"—buy a superior system that will remain compatible with their current videogames.

# ATARI'S 5200: A SUPER SYSTEM

## INSIDE THE CONSOLE

Beneath the sleek exterior of the Atari 5200 lurks the throbbing power of a 64K computer designed specifically to play high-quality games. This third wave programmable gaming system has the screen-RAM needed to get the job done, too, and the initial group of cartridge releases looks at least as good as the carts for the company's 400 and 800 computer systems with some improvement.

Game functions such as pause and reset are handled with the controllers, so the console sports a clean and uncluttered look that is most attractive. It physically resembles the housing originally scheduled for use on the remote control VCS, though the overall effect is even better.

The controllers for the new

system are a gallant attempt at crossbreeding the trakball and conventional joystick. The harder the stick is pushed in any given direction, the faster the on-screen moving object zips across the playfield. Atari must be congratulated for its attempt, but the examples tested by **EG** demonstrate that there are still some bugs needing to be ironed out. (Atari intends to have a true Trakball controller available soon.)

## ATARI 5200 SOFTWARE

How exciting the 5200 software list looks will largely depend on the viewer's vantage point. Those who already own an Atari 400 or 800 computer—or possibly even a VCS—will not be quite as enthusiastic about the selection as someone who has owned

either a different brand of fun machine or is about to make a first videogame purchase.

Like any new system, there isn't a lot of variety yet. Most of the cartridges are tried-and-true Atari Classics like

**Missile Command** and **Space Invaders**, altered slightly from their computer versions. The line also includes football and baseball games as well as Atari's official home edition of **Galaxian**.

ATARI 5200





# VECTREX:

## The Programmable Stand-Alone

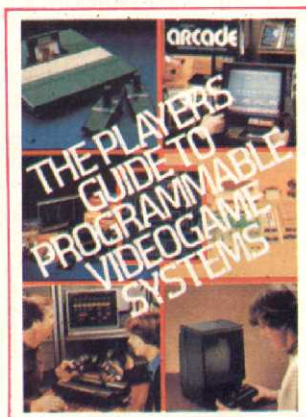

Access to the family television set has always been essential to gamers. Even the best videogame system was useless without an output device such as is provided by a TV picture tube.

At least, that was the situation until the introduction of Vectrex, a self-contained system built around a 9-in. diagonal vector graphics monitor. This technology, employed to stunning effect on Atari's *Asteroids* coin-op, produces luminous, crisp line-work with a lot of three-dimensionality.

The Vectrex's monitor is black and white, but this isn't quite as big a drawback as you'd think. Easing things a bit is the clever use of color overlays. With some cartridges, such as *Scramble* or *Rip-Off*, you can almost forget everything is black and white in the heat of action.

The cartridge line is still very small, but it's all good-quality stuff. *Scramble*, in particular, is one of the classiest scrolling shoot-outs produced for any videogame system this year.

Other notable cartridges include *Hyperchase*, a multi-scenario racing game, and *Star Trek*, a deep-space shoot-out. The Vectrex comes with one game, *Mindstorm*, resident, and it's so good that it probably would have sold well as a separate cartridge.

### Arcadia 2001: Portable & Powerful

This senior programmable videogame system has just become available as this issue of *Electronic Games* goes to press. Although it's not for everyone, this Emerson fun



ARCADIA 2001

machine appears to have a definite role to play in the hobby.

Since it operates on direct as well as alternating current, the Arcadia 2001 makes a perfect portable. Its small size won't take up much baggage space, so it can come along on vacations and trips.

Another amazing thing about the Arcadia 2001 is the price. It's selling for \$99 in discount outlets, the lowest-ever price for a senior system.

In truth, the Arcadia 2001 does have some drawbacks. The controllers aren't very responsive and the game graphics, though good as far as they go, are a little sparse. There's a library of a couple of dozen cartridges to keep gamers entertained.

### WHAT'S NEXT FOR VIDEOGAMES?

The future of home programmable videogame systems holds—you guessed it!—more new systems.

Making its debut next month will be Ultravision. This premium-priced unit is a stand-alone programmable with 64K of resident memory, high fidelity sound (including a headphone option), professional-quality 16 position joystick and its own high resolution color monitor.

On its way from Commodore is Max, slotted as the junior member of the company's line of machines which includes the VIC-20, VIC-64 and PET. Not much is known about the capabilities of the Max, but it is expected to be a senior programmable videogame system that will also provide a sampling of the joys of personal computers.

There are undoubtedly other systems waiting in the wings even beyond these. Despite the popularity of videogames, only 15% or so of all American families have them, leaving plenty of room for new entries into the field to grab a sizable audience.

VECTREX

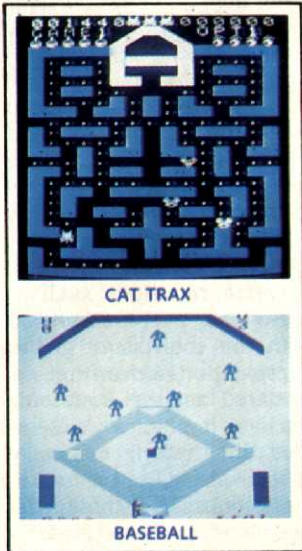
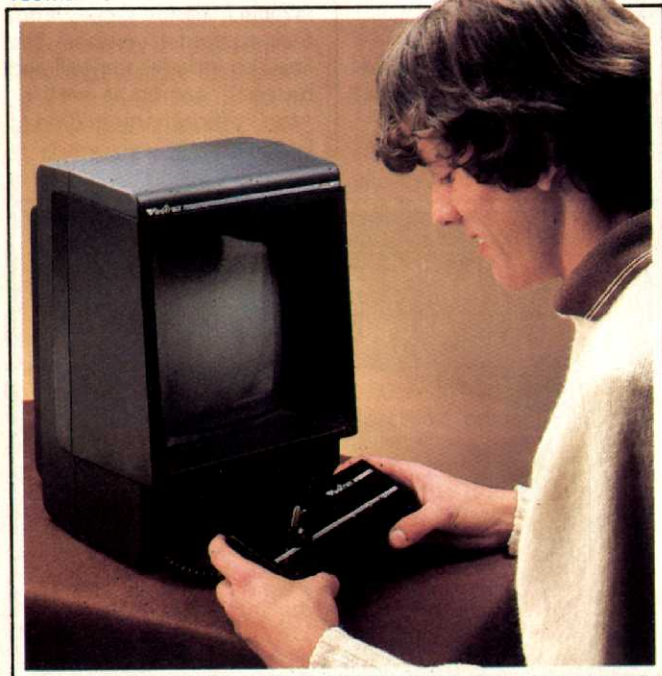



# BEWARE OF MUTANTS. THE REAL STAR RAIDERS!™ IS ONLY FROM ATARI.

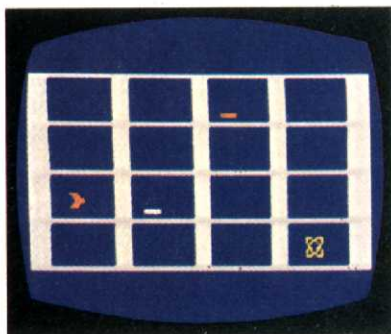

Play STAR RAIDERS, complete with its unique video touchpad! Use it in addition to your joystick to activate your shields, engage your tracking computer ... Then punch up hyperwarp, and get after the marauders!

Let the Krylons eat photon torpedoes, and rocket into action with STAR RAIDERS!

Don't play around with imitations. ATARI games are the real thing.

**ATARI**





# INSIDE GAMING

Fernando Herrera's story is so close to a Hollywood film script that it seems fitting that he should join up with two movie producers to develop a computer software company.

The producers, Richard Spitalny and Bill Blake, are best known for their flick "The Night the Lights Went Out in Georgia", but by joining up with the incredibly gifted Fernando, they may soon eclipse all their past successes.

Fernando first came to *EG's* attention via the arrival of a review copy of *Space Chase*, a science fiction arcade contest written in Atari BASIC. Published by the Long Island-based Swifty Software, *Space Chase* remains one of the most challenging and innovative SF contests ever produced.

The object of the game is to "conquer" the plethora of planets that dot the extraterrestrial playfield by passing over them. The gamer's craft, in turn, is pursued by a tie-fighter-styled series of scout ships their sole purpose is to ram and destroy the player's ship. The player has several weapons at his command. Bombs can be jettisoned from the rear of the rocket as it moves along, destroying any hapless kamikazes on the ship's tail, and the

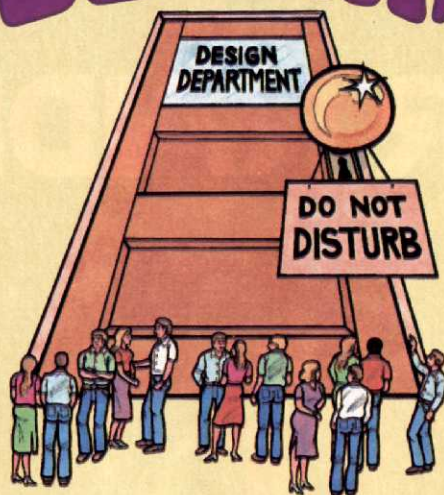

## Fernando Herrera — First Star in the Atari Universe

By WILL RICHARDSON

arcader's ship can "wraparound" or scroll off the screen at one point and reappear on the other side of the playfield.

If a scout ship's wiped out, a new craft is instantly generated from the same base. Each scenario the gamer successfully completes brings another enemy base into action until all three of the alien base-stars are pumping out

death ships like hamburgers at Mac-Donalds.

The game is notable for the simple, but perfectly suited graphics, excellent play-action—probably the fastest BASIC program ever written for the Atari computers — and totally original play concept.

When a program of this astonishing quality issues from an obscure programmer via a one-man software house (Swifty is run by an affable schoolteacher named Lee Jackson, a prominent mover in the creation of New York-based Atari computer user groups), the videogame journalist's instincts immediately take over. What's the story with this Herrera, we wondered? Where had he been hiding all these years?

The answer, as previously mentioned, is almost too good a story to be true. Born in Bogota, Columbia 39 years ago, Herrera's artistic talents were evidenced from an early age. He could draw, paint and, by the ripe old age of eight, was making his very own 8mm movies!

After copping a degree in architecture from the National University of Columbia (and finishing in the top 5% of his class) Fernando spent three years pursuing that ambition before moving to the U.S. in 1970. While employed as an Industrial Engineer for a steel company, he also found time to win several chess trophies from the U.S.C.F. (the United States Chess Federation).

In the late 1970's, however, Fernando discovered an interest that soon replaced his passion for chess — personal computers. He read everything available on the subject, even writing programs himself for a whole year before he actually got around to buying one. It was this new hobby that proved to be not only a door-opener to a new career, but a personal triumph as well.

Fernando's son, Steve, born with severe cataracts, was pronounced blind by every medical specialist who examined the boy. Fernando, however, refused to accept this judgement

DAANGEROUS CARGO

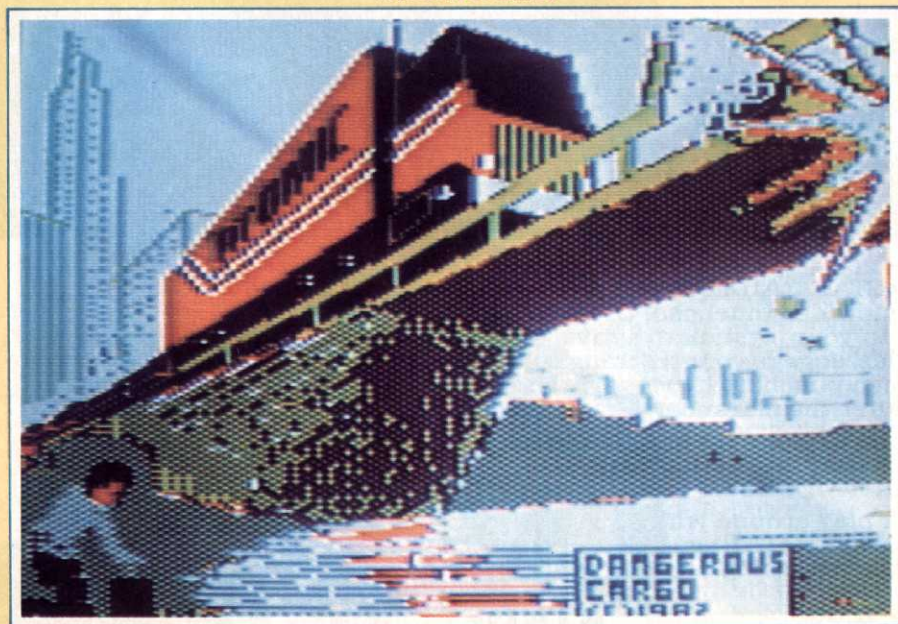



and set about to insure that Steve's education would progress normally. He immediately took steps to create a program to help his boy learn the alphabet. After months of work, Fernando proved the medical profession wrong by successfully utilizing his teaching program, allowing Steve to make great strides in overcoming his handicap.

That program ultimately metamorphosed into **My First Alphabet**, a design that won Fernando the prestigious first annual Star Award of Merit from Atari in 1981. He became the first designer to win the \$25,000 Grand Prize and Atari has now added the highly effective learning aid to its software line. *My First Alphabet* has proven invaluable in teaching depth perception, size ratios and, of course, the letters of the alphabet themselves.

Today, Fernando is sitting atop the booming market for Atari computer game software. Lead by a canny perception of the audience with which they are dealing, First Star Software, as the embryonic venture is known, will initially deal with a maximum of 32K memory — so that the software will run on any Atari computer.

"A videogame is like a puzzle," Fernando explains. "You can't rush it. When it finally comes together, I sit down for 24 solid hours — no food, bathroom, nothing — until it's completed."

One of the Atari computer systems' greatest boosters, Fernando feels certain that, "We have only begun to scratch the surface of what this computer can do. You can do things with the Atari that no other computer can emulate."

His approach to game design sounds

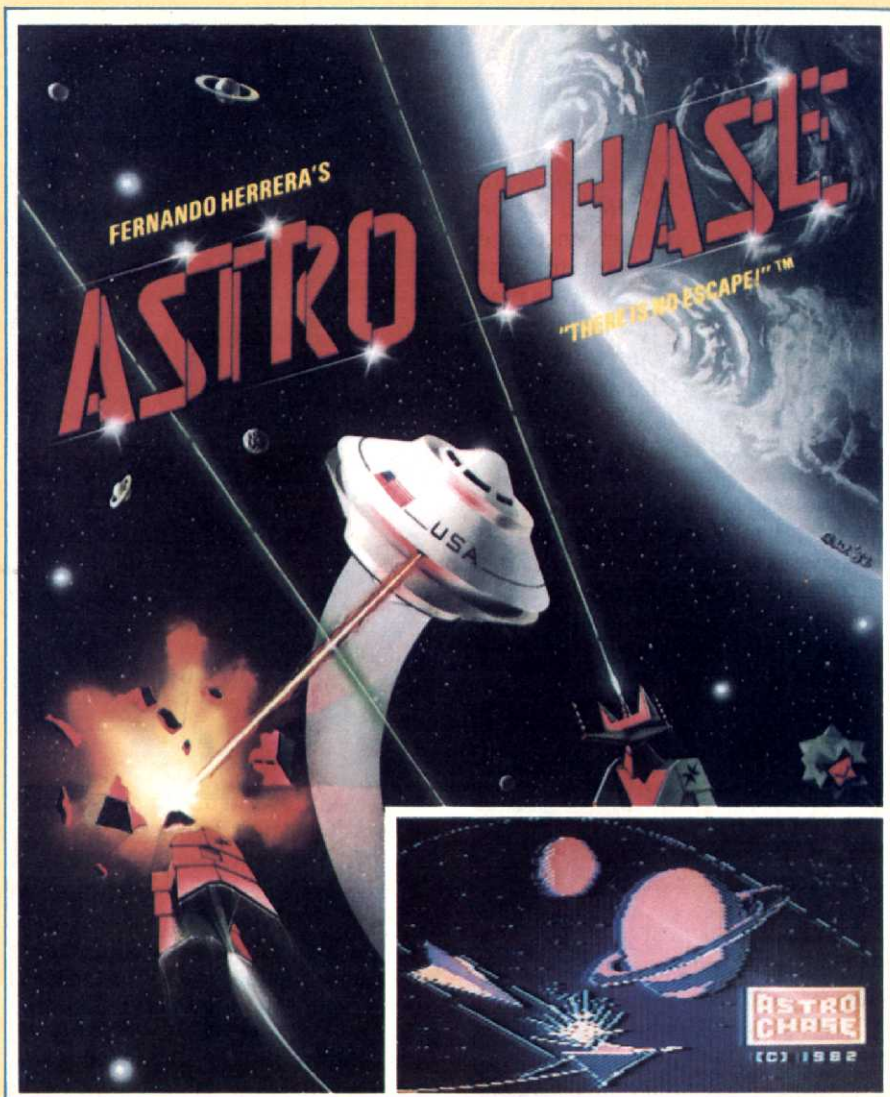

ASTRO CHASE PLAYFIELD

deceptively simple — but it may only work for someone with Fernando's natural genius with computers. "The user is paramount. I must look at all my programs through the user's eyes." He never thinks in terms of the system's supposed limitations, but rather how to overcome such problems. He speaks in short, concise sentences, tossing off such insightful remarks as, "I don't move data — I move graphics."

The first game to be released under the First Star banner will be an arcade quality space shoot-out dubbed **Astro Chase**. The game revolves around the defense of planet Earth from invading aliens and features not only spectacular graphics, scrolling and audio (or should that be "sound track"?), but a technical innovation that could cause a minor revolution in videogaming. This proprietary process allows the human pilot to lock his craft on course and then fire independently in any direction. Unlike past contests of this type, in which gamers could only

fire in the direction of travel, "single thrust propulsion" allows players a flexibility never before available. Imagine running from an alien craft and being able to fire *backwards* while in the midst of a retreat.

*Astro Chase* is a sure-fire software hit. Future games will make more use of Spitalny and Blake's movie background in picking the program concepts. The second scheduled release, **Dangerous Cargo**, is a trucking game that will also debut in film format sometime next year. The increasing kinship between movies and videogames has only begun to be explored, and the thought of a Fernando Herrera creating a computer game based on, say, "Road Warrior", is enough to stir the blood of any true arcader.

Fernando, meanwhile, remains unaffected by his sudden celebrity. His main concern is still how to get the best possible game on the TV screen. It's a job he handles with a star's touch. ☺



FERNANDO HERRERA



Ah, 1982—what a year for arcaders everywhere! Never before did the coin-op gourmet encounter such a *smorgasbord* of electronic arcade contests. And not only were there more games, but the product was unilaterally improved in terms of sound and graphics over the output from previous years. Greater variety in terms of play mechanics was also obvious—no longer was every new game a prettied-up variation of *Space Invaders*, *Pac-Man* or *Defender*. Instead, we saw maze shoot-outs, climbing contests, digging games, and even two-player contests where the games co-operated to eliminate some computer-generated menace.

This proliferation of titles will probably cause the summer of '82 to be remembered as a "golden era" by arcaders. Even though gamers spent more money in the pleasure palaces of America, the money was split among a far greater number of titles. This will probably result in a shakeout of the weaker sisters in the industry. In other words, we may never again see as many new titles in such a short span of time. Enjoy it while you can, fellow coin-oppers!

The Japanese presence was not nearly so overwhelming in 1982, with companies such as Midway, Exidy and Williams releasing largely in-house created videogames. Atari, meanwhile, previously the number one creator of home-grown coin-ops, broke with tradition and signed an agreement with Namco (creators of *Galaga*, *Pac-Man* and *Galaxian*



By BILL KUNKEL

## 1982—The Year in Coin-Ops

among many others) to release coin-ops created by the Japanese game wizards. The first contest to emerge from this partnership, *Dig-Dug*, is already looking solid in the arcades.

As a greater and greater number of games continue to compete for limited space, only the genuinely strong titles are surviving. The half-life of even the hit games grows shorter and shorter as the coin-op business comes to resemble the "hits" orientation of the music

industry. Games explode on the scene, such as Taito's innovative but abstract *Qix*, then begin to fade from sight. Other excellent titles that were given short-shrift by both distributors and the gaming public include the eye-popping *Kickman* and the Namco-created *Bosconian*, both from Midway.

The greatest improvement on the coin-op scene in the past 12 months has definitely come in terms of sound and graphics. Arcaders were left goggle-eyed after seeing such visual masterpieces as Sega's *Turbo* and *Zaxxon*. In fact, Sega capitalized on the tremendous player attraction of *Zaxxon* and produced the first television commercial advertising a coin-op videogame. Blending the game's own high-resolution visuals with some dynamic animation work, the ad is a roller coaster ride full of color and excitement.

Maze games certainly maintained their popularity, with *Ms. Pac-Man* rating as the top earner through most of the summer. There was also a wide assortment of digging and climbing contests with multiple playfields and multi-scenario games becoming commonplace.

In these inflationary times, gamers may be among the select few consumers who actually got more for their money. Not only have players gotten better, but improved instructions, animated introductory sequences and added "lives" or turns-per-play have all increased the time a gamer spends at his or her favorite machine. Addi-

ZAXXON PLAYFIELDS

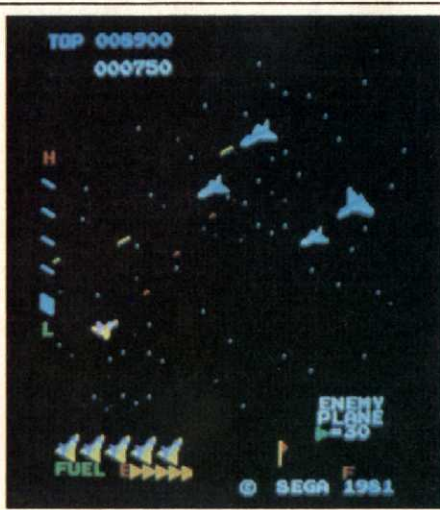





QIX

KICKMAN

FROGGER

tionally, the trend toward two-token or 50¢ plays seems to have pretty much fizzled.

While *Ms. Pac-Man* and *Zaxxon* remained strong through most of the summer, several powerful contenders appeared on the scene to steal their thunder. First, Williams introduced **Robotron**, the third in their *Defender* series, in which the lone space knight actually lands on the ravaged planet in order to rescue the remaining humans and blitz the various types of alien creepies. *Robotron* presented arcaders with more on-screen movement than had ever been seen before. Screen-RAM is the technical name for the ability of a computer to simultaneously manipulate on-screen graphic elements, and *Robotron* had screen-RAM

coming out its ears. Swarms of aliens descend upon the hapless defender from all directions, while he blasts back at them with automatic-laser fire.

Just as the Williams classic began to take off, the Walt Disney arcade movie spectacle, "Tron", opened across the country, sparking even greater videogame madness. Midway's version of the computerized world of *Tron* combined four totally independent contests: a tank-maze shoot-out; a battle to reach the I/O Tower; a light-cycle challenge; and a confrontation with the MCP (Master Control Program). The wide variety of action and extended playing time helped boost the videogame-based-on-a-movie-based-on-videogames a healthy success.

As the year comes to a close, a new batch of titles are being hailed as the "Next Big Things". **Jungle King** and **Space Dungeon** are both drawing excellent notices, as is Atari's **Kangaroo**. The coin-op world is even abuzz with rumors concerning 3-D videogames currently being tested in Germany.

If 1982 showed us anything, it's that the day of the Big Game may well be



Atari's *Space Duel* recreated the excitement of *Asteroids* with full-color vector graphics and a few new touches.

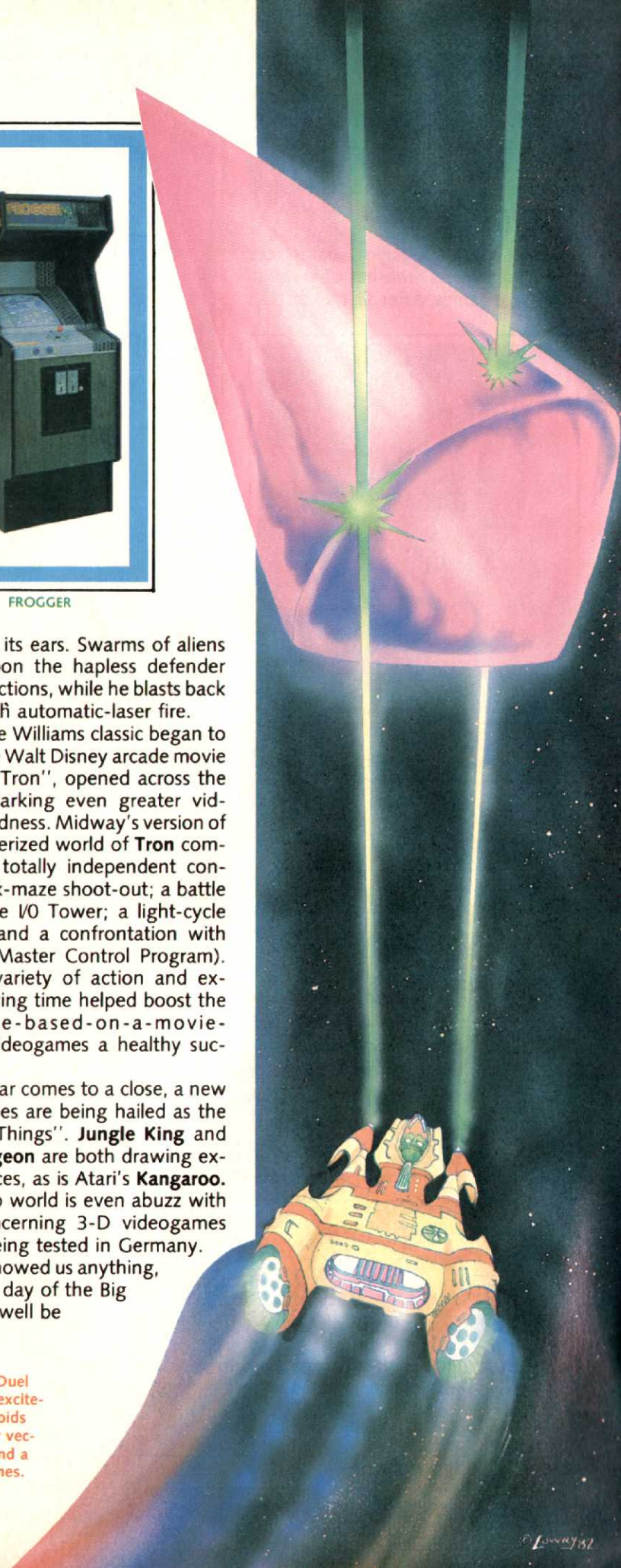



over. There are just too many titles around for any one machine to overwhelmingly dominate the game scene the way, for example, *Pac-Man* did in '81. It's also clear that the me-too games are going straight down the tubes. Prettied up versions of existing games just don't ring the bell with today's sophisticated gamer. It's also obvious that today's players want more than just endless rehashes of invasion and maze games. After all, two of '82's



TV AD FOR ZAXXON

biggest hits were Atari's *Tempest* and Sega's *Frogger*, neither of which fit into any pre-constructed molds or categories.

The watchword is invention! As graphic and sound capabilities continue to mushroom, good, original games will be needed to take advantage of them. As home systems con-

tinue to offer ever more impressive versions of arcade games, the coin-ops are going to have to take some serious steps to remain a couple of jumps ahead.

Next issue, we'll be back with our regular column, but we'd very much like to hear from you regarding the year 1982 in the arcades. What kind of year did you feel it was? What impressed you most? What was your biggest disappointment? We'll be waiting. ☺

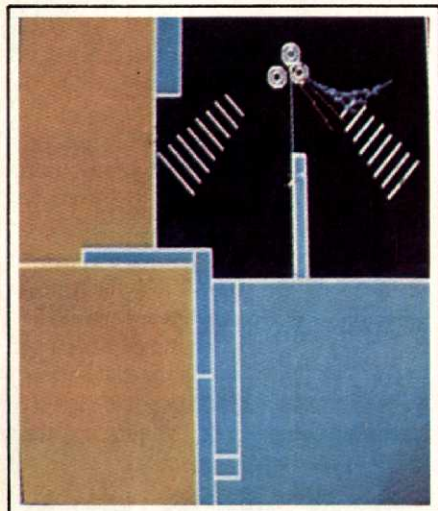

QIX PLAYFIELD

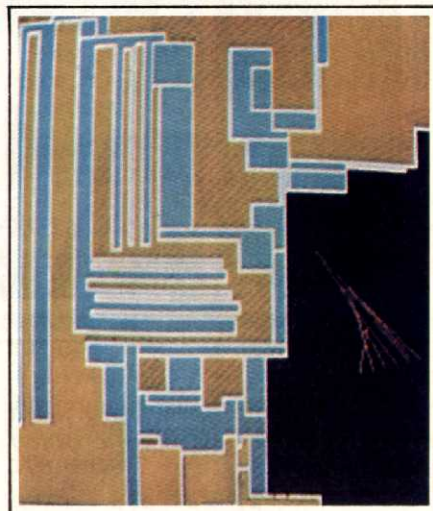

QIX

# Supercharge your Atari!

Plug the BC BLASTER™ into your Atari or VIC 20 in place of the joystick for

- Higher Scores
- Super Rapid-Fire
- No Cramped Hands
- Responsive Button Control

The BC Blaster is: five feather-touch push buttons, housed in a 8½" x 5" control panel with a 6 foot cord. Use the BC Blaster instead of the joystick and experience fast, arcade-like action with the controller that makes your home game work like an arcade.



Pat. Pend.

**Mail to:**

**BC-Systems  
59 W. Wyoming Ave.  
Melrose, MA 02176**

Rush me the BC-Blaster! I enclose \$29.95 plus \$3.00 postage and handling for each unit. (Massachusetts residents add 5% sales tax.)

Name \_\_\_\_\_  
Address \_\_\_\_\_  
City \_\_\_\_\_ State \_\_\_\_\_ Zip \_\_\_\_\_  
M/C number \_\_\_\_\_ Visa number \_\_\_\_\_  
Exp. date \_\_\_\_\_



# SATAN'S HOLLOW

The hot new battle game that dares you to cross the blazing Bridge of Fire to do battle with the Master of Darkness—Satan of the Hollow!

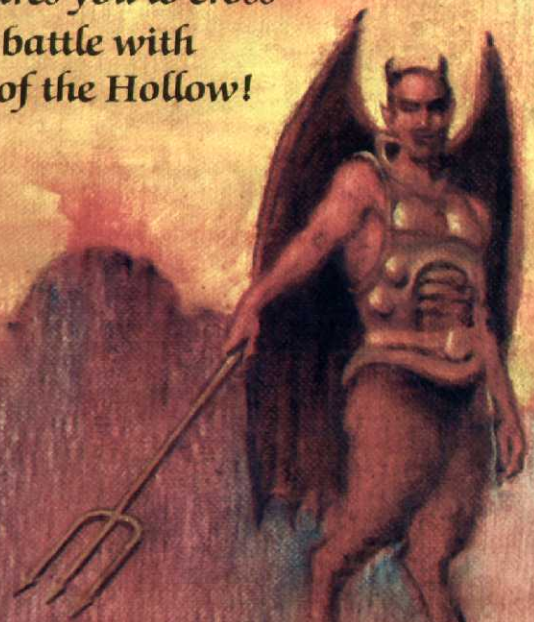

The Dark Scrolls warn of the perils of Satan's hollow. He, the Prince of Darkness, reigns over an infernal underworld so abhorrent, the grotesque gargoyles who safeguard his lair cower at his clovenhoofed approach. 'Tis he who rules supremely his domain, by twisted swirls of flame and obedient creatures so wretched, no mortal dareth traverse the Bridge of Death crossing the River of Fire. Beware him. He is darkness, he is the omnipotent demon Lucifer, he is SATAN OF THE HOLLOW.

**Bally** | **MIDWAY**

©1982 Bally-Midway Mfg. Co.



# ARCADE

## The Best Little Arcade Club in California

If New York is known for its skyscrapers and Texas for its oil wells, then Mountain View, a small area in scenic Northern California, is certainly the arcade capital of the nation.

Because of its proximity to the so-called "Silicon Valley", the Sunnyvale-Santa Clara-San Jose area where a large percentage of all videogame and computer-related products are manufactured, Mountain View perhaps has the hippest arcade-goers in the world. How, then, does an arcade such as the Central Park Family Fun Center, which is neither part of a chain nor jam-packed with every coin-op in existence, survive? (CPFFC has about 50 games. Though there is room for more, they prefer to keep their two-room, 3,000-square-foot location as wide open and relaxed as possible.)

"We keep only up-to-date machines," explains manager Larry Kanzaki, "keep the place clean and insure a pleasant environment. We even have a place to sit and rest."

Ah, but there's more to it than that! CPFFC is actually an arcade *club*, and is operated on a membership basis. The entry fee is nominal—\$1—and each member receives a card entitling him or her to a free game token on every visit. An extra special benefit of mem-





# AMERICA

By DAVID LUSTIG



bership comes on an arcader's birthday, when they receive *ten* free tokens!

Central Park has taken another step in this area that may be even more innovative: for every "A" or "B" a member gets on a report card in an academic subject, the arcade awards a pair of tokens. In addition, members are eligible to enter the weekly high-score contests.

The club's youngest member, by the way, is four. Its oldest veteran is 70!

The most popular games are **Tempest**, **Defender** and **Centipede**, in that order. There is exactly one foosball table. Why not more? According to Kanzaki, "A few years ago, foosball was very big in this area, but not any more. It just died out. Pool tables seem to bring a negative aspect to the place and make it a hangout, so we don't have them, either—and no jukeboxes.

The center's biggest problems? People banging the machines and fervent arcaders reluctant to leave at closing time. Certainly not the type of difficulties Henry Kissinger need be called in on. In any case, Larry has found the ideal solution to the problem of compulsive gamers who just can't quit: he pulls the plug at closing time.

The hottest new machines on the game horizon are, as far as Larry Kanzaki can see, **Ms. Pac-Man** and **Hyperball**.

What about more arcade clubs? The opportunities look excellent, especially when they're run with the intelligence and sensitivity of the Central Park Family Fun Center.







**NOW YOU  
CAN TELL THE  
DIFFERENCE  
BETWEEN  
INTELLIVISION®  
AND ATARI®\*  
WITH YOUR  
EYES CLOSED.**





The difference has always been easy to see. Intellivision® has brilliant graphics, lifelike figures and realistic gameplay. Intellivision has the hand controller with 16 positions. The Atari® VCS has a joy stick with only half as many.

The Intellivision system is expandable.

But now, the difference is even more obvious. In case you haven't heard, Intellivision actually talks.

It's true. Just attach the new IntelliVoice™ voice synthesis module. Plug in any one of our new talking cartridges. Then, concentrate on the visual action. While IntelliVoice gives you up-to-the-second verbal status reports. Feedback. And instructions which are essential to your game strategy.

Voice is just one innovation, though.

If you like arcade maze games, you'll love new Lock 'N' Chase.\*\* And wait until you see Night Stalker,™ with its relentless one-eyed robot.

Of course, your dealer can show you the difference between Intellivision and Atari. For your nearest dealer, call toll free 1 (800) 323-1715. In Illinois, 1 (800) 942-8881. Or shut your eyes, and let **MATTEL ELECTRONICS®** Intellivision speak for itself.

**INTELLIVISION®**



# COMPUTER

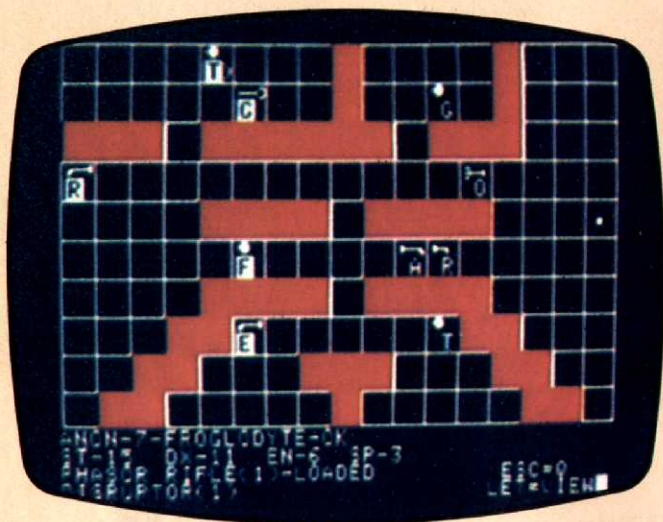

GALACTIC GLADIATORS' PLAYFIELD

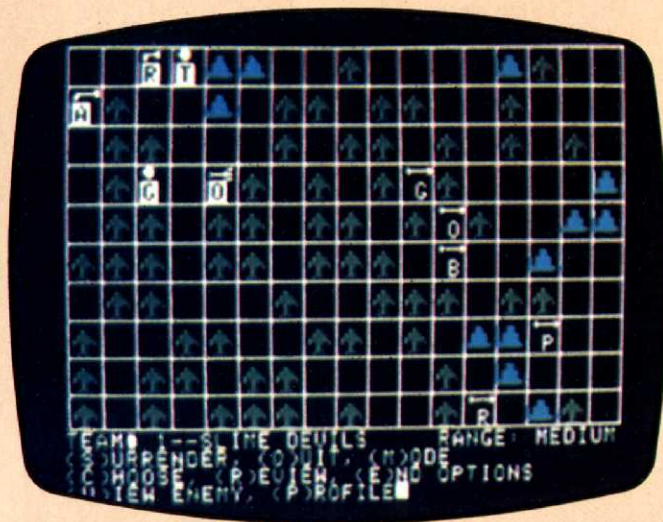

GALACTIC GLADIATORS' PLAYFIELD

## GALACTIC GLADIATOR

Strategic Simulations/Apple II/48K disk

Most computerized combat games can be placed at the extreme ends of the size spectrum. They either involve the clash of large forces or else simulate the exploits of a lone hero against a succession of enemies. **Galactic Gladiator**, the first release in the new series of *Rapidfire* games from Strategic Simulations, falls neatly into neither category. This decidedly out-of-the-ordinary program focuses on engagements between small teams of fighters.

Despite the title of the game, there's a lot more than arena-style combat available in this one- or two-player game. (The computer directs one side for solo play, but the Apple II usually needs a two-fighter advantage to keep the battle fairly even.) Combats can take place in a variety of settings, ranging from a three-against-three barroom brawl in an establishment known as "Mike's" to a seven-versus-seven donnybrook on the home world of one of the seven standard species which are included in the game.

Not only can the individual gamer create a broad array of customized

scenarios, but designer Tom Reamy has gone all out to make this as painless as possible. The rather voluminous instruction manual includes complete information about how to build a quest (a group of five semi-linked combat episodes) from scratch with surprisingly little difficulty. The booklet also includes the background for the game, extensive player aids and quite a bit of information about why things happen the way they do during the course of play. Lucid descriptions of how things work in *Galactic Gladiator* make it a lot easier for players to develop strategies, because they don't have to do a lot of guessing and estimating.

The participants in the on-screen martial mayhem are drawn from seven basic specials which populate various star systems circa the 28th century. In addition, there are seven non-standard species, including robots, mutants and monsters. Each individual fighter is rated in six characteristics—strength, dexterity, endurance, speed, experience and weapons skill. Each quality governs one or more specific aspects of the game. For example, speed determines both how far each fighter can move in a single combat turn and also





# GAMING

## Can Your Combat Team Survive Galactic Gladiator's Deadly Arena?

indicates which will get to move first. Strength, on the other hand, determines what kind of arms and armor a battler can carry into the fray as well as how much damage it takes to kill or stun that fighter.

Variety is the hallmark of *Galactic Gladiator*. Even before getting into the design-it-yourself options, there is an amazing flexibility that is guaranteed to keep this program from going stale the first week out of its box. And by the time truly dedicated fans of *Galactic*

*Gladiator* have explored most of the nuances of the original game, Reamy plans to have a data disk available that will add a raft of new possibilities to investigate.

*Galactic Gladiator* has all the elements of a potential cult classic. It gives gamers so much input into the design of scenarios while keeping actual play smooth and simple, leaving players free to exercise their brain cells on concocting all kinds of weird, deadly strategies.

(Arnie Katz)

GALACTIC GLADIATORS

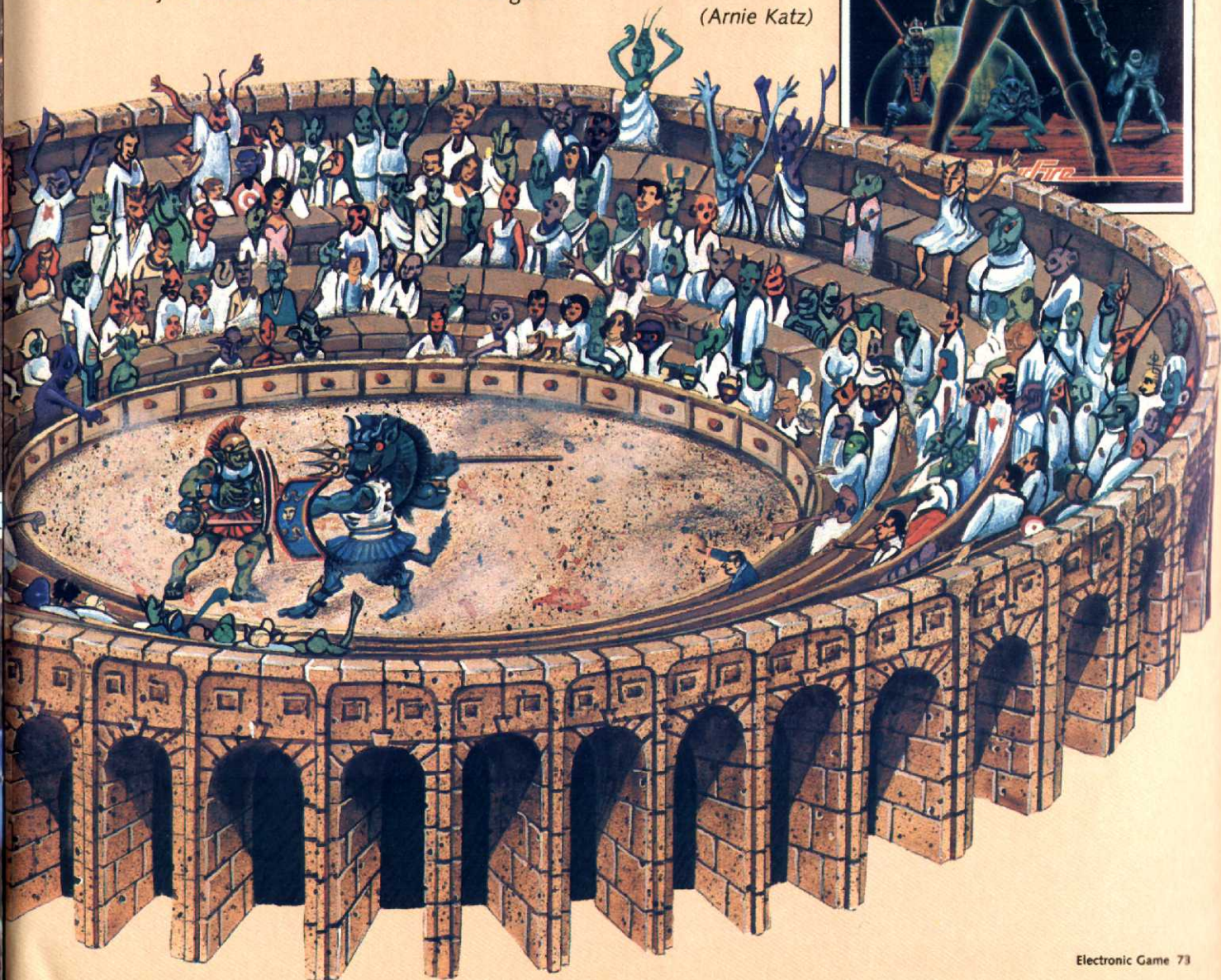
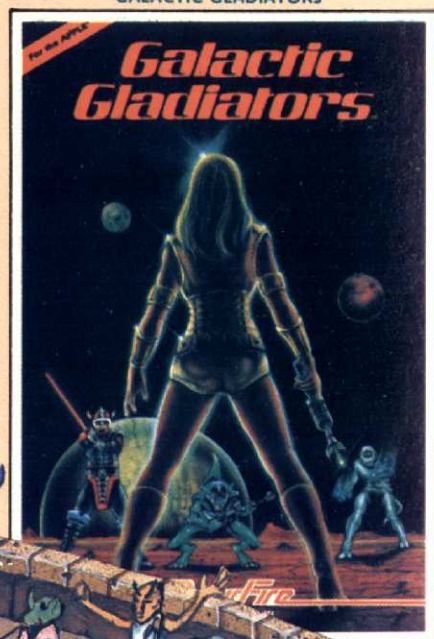



# PLAYFC

COMPUTER GAMES THAT ARE THE CLOS

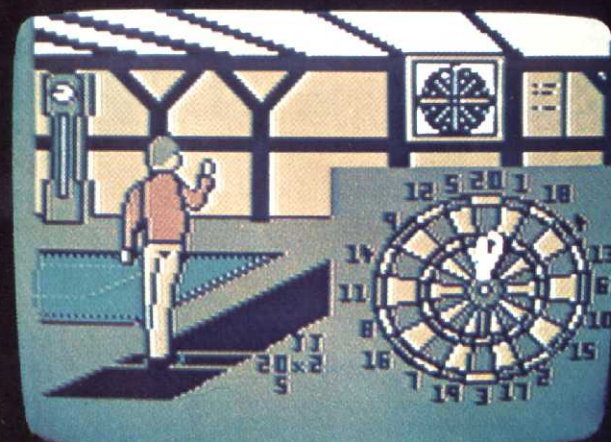
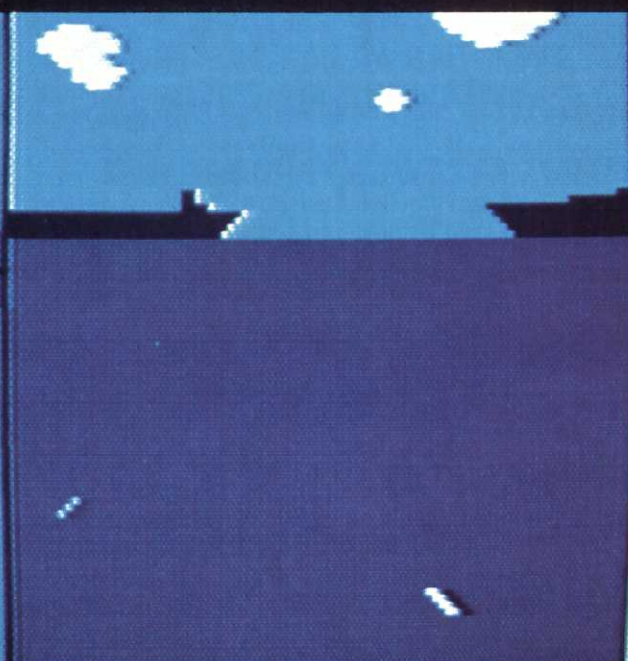



# OR REAL

**BEST THINGS TO REAL LIFE CHALLENGES.**

## **THORN EMI** VIDEO

THORN EMI Video Programming Enterprises, Inc., part of the international entertainment giant, announces 21 computer games that are so real, so challenging, you'll almost forget you're playing a game. You'll be playing for real. No wonder. The graphics are amazingly real-to-life. Action packed. You'll know the moment you start playing one you aren't playing any ordinary computer game. You'll be concentrating too hard.

Take *Submarine Commander*. Your mission? To hunt down and destroy all enemy merchant shipping in Mediterranean waters. How? With your sonar and torpedoes. What if you're attacked? Dive (but not too deep, or you'll crack the hull), dodging the depth charges. Remember to keep checking the instruments for your oxygen level, fuel, battery charge, depth under keel. And keep a sharp lookout for enemy destroyers.

With 21 exciting games to choose from, THORN EMI offers a game for every member of the family. There are super realistic simulator games, like *Submarine Commander* and *Jumbo Jet Pilot*, sports games with lots of fast action, nursery rhyme puzzles, even a financial management game. All have different levels of challenge, so you can make them as challenging as you want, and they can be played on the Atari® 400 and 800 and the VIC® 20. Whatever your favorite pastime—playing pool or darts, soccer or driving a power boat, composing music or doing the Cube, THORN EMI has a game just for you.



Atari is a registered trademark of Atari, Inc.  
VIC 20 is a registered trademark of Commodore International, Inc.

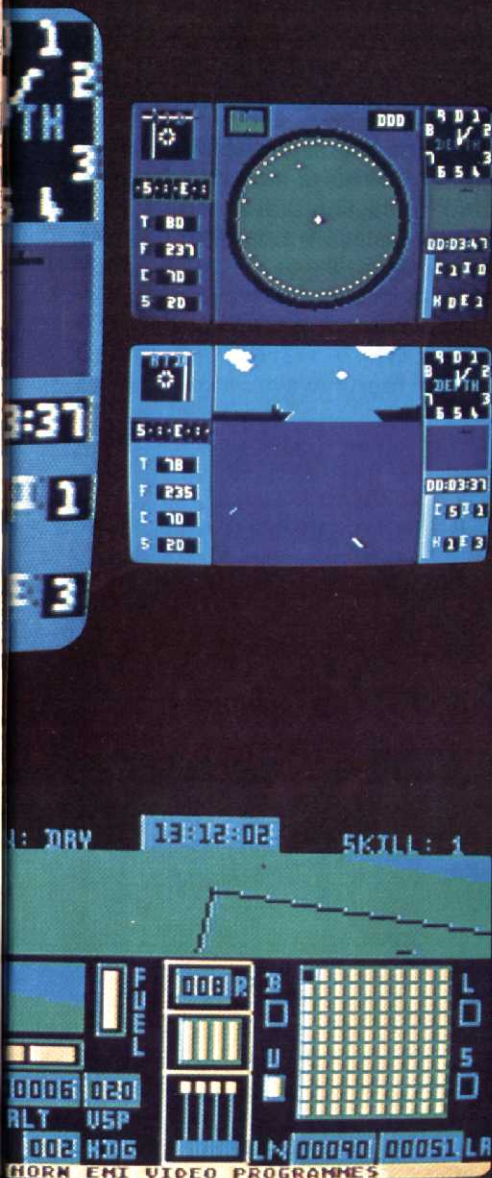



## DELUXE COMPUTER STOCKS & BONDS

Avalon Hill/Atari 400&800/48K disk

Avalon Hill has acquired an enviable reputation for quality in the non-electronic gaming field. Ever since Charles Roberts, after whom a series of gaming awards is now named, produced the first war board game, **Tactics**, the Baltimore-based company has stood at the top of the adventure gaming industry. Many of the advances which paved the way for adventure gaming's current popularity, such as the invention of the hexagonal movement grid, came from Avalon Hill.

Sad to say, AH hasn't yet duplicated this performance in the computer game software arena. Although there have been some good games, including the ever-popular text adventure **Empire of the Over-Mind**, titles of the Microcomputer Games Division have frequently turned out to be something less than exciting. The company's designers don't seem as conversant with the doings of the other software publishers as they should be, with the result that Avalon Hill computer games frequently fall short of whatever is state-of-the-art at the time of their release.

This deluxe edition of **Computer Stocks & Bonds** suggests that AH may now be ready to take its proper place in the mainstream of the computer

software world. Based on the popular non-electronic money game of the same title, **Stocks & Bonds** makes it mighty easy for computerists to try their hand at being Wall Street stock manipulators. Ten securities, described briefly in the rules folder, are up for grabs. The player who knows when to buy and sell most effectively wins this 10-turn contest by accumulating the greatest net worth by the time of the final yearly turn.

The control scheme for **Stocks & Bonds** should draw raves from money game fans. Everything, including the amounts in buy or sell orders, is entered using the joystick, and from one to four players can go about their business simultaneously, instead of having to wait for a turn at the keyboard.

This greatly speeds up play in what is, at least potentially, a pretty complicated game. The only time there's an appreciable delay is when one or more of the financiers requests stock history information. Since this requires the computer to bring a new display screen onto the monitor, other players must cool their heels while one participant is performing such analysis.

**Stocks & Bonds** was a winner as a

board game, and there's no reason to think that this deluxe computerized version won't find a wide audience among owners of the Atari computer system.

(Steve Davidson)

## STARBLASTER

Piccadilly Software/Apple II/48K disk

There's nothing radically different about this scrolling shoot-out, but the guess here is that most Applers will want to add it to their collection of games. Although Piccadilly's designers started with a mediocre concept, the execution is so faultless that **Starblaster** is a real joy to play.

The computerist controls a trio of Earth space cruisers, light and maneuverable ships which become available one at a time as the previous cruiser falls victim to some enemy's attack. Players move their ships with the joystick (or paddle, since there's a choice) and fire the nose-mounted laser by hitting the action button.

Seven distinct waves of trouble are waiting to challenge the cruiser. They line up as follows: first wave, mines (15 points); second wave, invaders (50 points); third wave, comets (20 points); fourth wave, force field (5

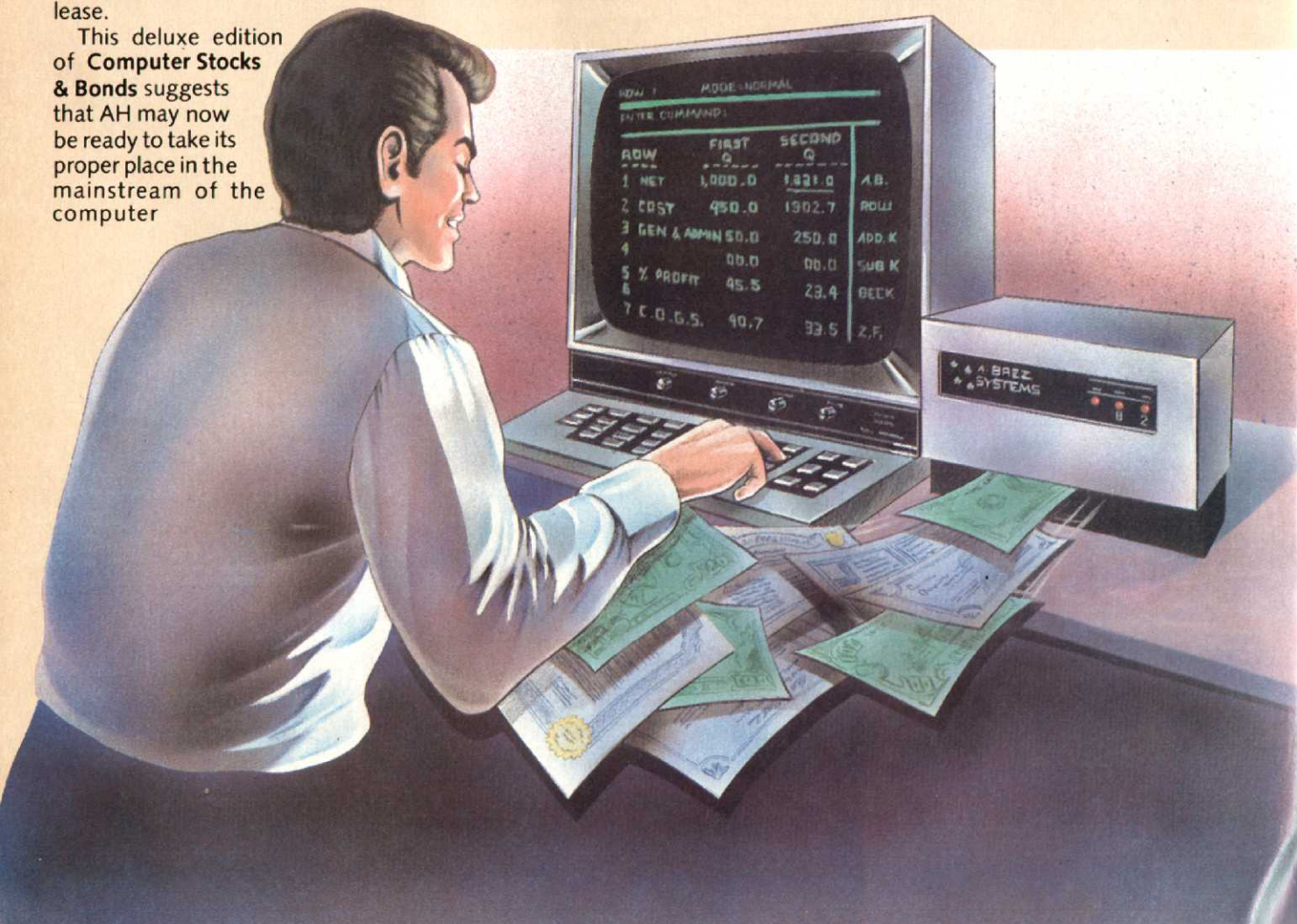



# FUN IN THE SUN

It's 110° in the shade. And you're about to have the time of your life in the most exciting road race ever created. BAJA BUGGIES™ by GAMESTAR. For the ATARI® 400/800™ Home Computers.

It's just you and your super-charged machine against some of the best race drivers in the world. "Legends" like A.J. Cactus, Mario Sandduni, and Parnelli Pothole. Each determined to push you to your limits, race after race.



BAJA BUGGIES™ breaks new ground with absolutely stunning visuals. Amazingly realistic racing sounds. And all the thrills, spills and excitement of real road racing. As only sophisticated ATARI® 400/800™ Home Computer entertainment can.

So climb into your buggy, put on your helmet and get set for a little fun in the sun—BAJA BUGGIES™ by GAMESTAR. Look for it at your nearest ATARI® retailer.

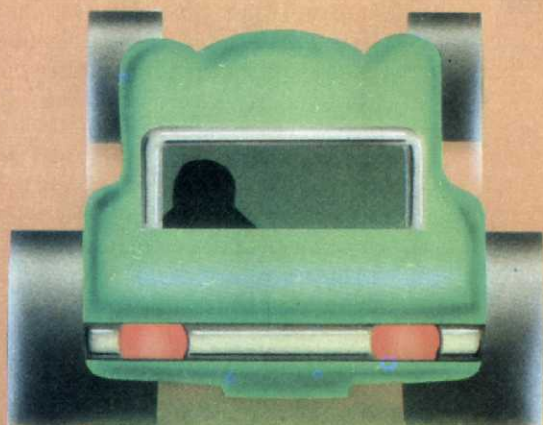
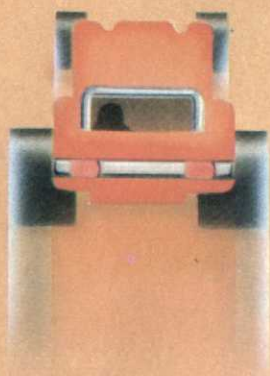

**GAMESTAR** 

**WE BRING OUT THE STAR IN YOU.**

1302 State Street, Santa Barbara, CA 93101 (805) 963-3487



points); fifth wave, guardians, (55-85 points depending on the skill level); sixth wave, space rocks (50-75 points) and seventh wave, neutron bombs (25-75 points) and the Dragonian Annihilator (5,000-12,500 points). Bursting through the Annihilators defensive wall and blasting it to smithereens earns gamers the right to run through the whole obstacle course again at a higher level of difficulty. *Starblaster* has eight levels, each a bit faster or more complex than the last.

One often-heard complaint about scrolling shoot-outs is that only the good scorers ever get to see all the screens, while a player who's having a tougher time of it may spend 50 games trying to break out of the first scenario. *Starblaster* addresses this issue by providing a demonstration mode, which can be chosen by pressing the "D" key after the program boots. The demo can be an exhilarating experience for arcaders who ordinarily get trounced by *Tron* and zapped by *Zaxxon*. You can move and fire, but no amount of damage will cause you to lose a ship. To keep this sudden invincibility from overwhelming players, no points are recorded on the tote board.

The graphics in *Starblaster* rate as serviceable, but not spectacular. The design emphasizes clean linework and straightforward rendering rather than eyeball-searing pyrotechnics. Yet the on-screen images are well-drawn enough to escape the clunky look that sometimes mars cartridges in the videogame field. Sound effects aren't great, but that's as much the fault of the Apple as the programmer.

If you're looking for a good multi-scenario space game, *Starblaster* is a good bet.

(Steve Davidson)

## JUGGLER

*Innovative Design (IDS)/Apple II/48K disk*

The ability to juggle several objects in the air at the same time has always fascinated people. That's why just about every circus has someone tossing around a few clubs, knives or the like to the delight and amazement of the crowd.

That, in a nutshell, is the theme of the latest program from Innovative Design, a company that usually tries to live up to its name. IDS leaves the space shoot-outs, mazes and dragon hunts to other companies, and instead concentrates on producing fine games on somewhat offbeat subjects. *Juggler* stands tall beside the company's previ-

ous hits, *Pool 1.5* and *Shuffleboard*, in both freshness of approach and overall quality.

The arcader controls a series of three jugglers, available one at a time at the bottom of the display. A half-dozen items percolate out of a holding box in the lower right-hand corner, up a chute and onto the playing field.

The on-screen character automatically tosses objects into the air as the gamer moves him back and forth across the bottom of the screen. When a tossed object hits one of the tumbling items, it pushes the club, ball or hatchet back up the field. Each such hit scores 30 points multiplied by the level at which the game is played. Getting one of the tumbling items into the chute at the extreme left side or the mini-maze at the right earns a bonus of several hundred points.

There are two ways to set the diffi-



culty level. The gamer can select a starting level (1-7) by pressing the appropriate numeric key after the disk is booted and a new round is started by hitting the return key. The *Juggler* program also raises the difficulty one notch automatically whenever the countdown clock in the upper left-hand corner reaches zero, indicating you've kept 'em flying for an appropriate period. (The amount of time varies, depending on the level, but it's rarely less than a minute and can be a lot longer.)

When the disk boots, control defaults to the keyboard. Hitting one of the direction arrows moves the juggler that way on the screen. If automatic tossing isn't putting enough objects in the air to suit you, you can fling more toward the heavens by simply tapping any key on the Apple. Obviously, the more objects tossed, the more collisions with the tumbling objects occur, boosting the player's score. The downside is that every time the arcader opts for an extra object, the juggler moves one segment in the same direction as the last move made with a directional arrow. That makes it tough to send a heavy column of supporting objects into the air anywhere but at the two edges of the playfield. (Auto-toss cuts out at the higher skill levels, at which point the player is entirely dependent on drumming a key to keep the supply coming. (The juggler can also hit a tumbling item with his head or hands, earning a bonus in the process, but this should only be a last-ditch maneuver.)

Playing with the paddle gives the arcader much more accurate control of the juggler, but it also removes the auto-toss feature. Repeatedly pressing the action button sends the supports skyward.

Graphics have never been an IDS strength, and *Juggler* reflects this. The visuals are serviceable, but a little on the plain side. The play-action, on the other hand, is terrific—and it'll keep you too busy to think much about the artwork. *Juggler* is a distant cousin of *Kaboom!* (Activision), but its various unique features make *Juggler* a contest that depends as much on strategic planning as on pure hand-eye coordination. Fine stuff.

(Arnie Katz)

## DOG FIGHT II

*Micro Lab/Apple II/48K Disk*

For the most part, computer games can be considered worthwhile if they



# Syncro's Challenging Adventures

for the  
Atari\*  
400/800  
computers.



Syncro cassettes and disks  
can be ordered from your  
favorite dealer.

**MAZE OF DEATH**® A fast paced, action packed, color graphic adventure pitting you against a mad scientist. 16K cassette/ 24K disk.

**MAR TESORO**® Rent a boat and crew, and dive for sunken treasure. You can find a fortune or be crushed by a giant octopus in this color graphic adventure. 24K cassette/ 32K disk.

**DRAC IS BACK**® Roam the 200 room castle of Drac, but make certain you have wooden stakes and silver bullets. A non-graphic, multi-colored adventure with enlarged text. 24K cassette/32K disk.

**ALIEN HELL**® A color graphic adventure. Solve the riddle for your escape. A challenge for the experienced adventurer. 16K cassette/24K disk.

**WORDMANIA**® A challenging word game for 1 or 2 players. Developed to improve typing skills, word recognition, spelling and concentration. 16K cassette/ 24K disk.

**ASTRON IV**® As space warriors you battle robots and deadly Orbitron to destroy the pirate asteroid. A color graphic adventure. 16K cassette/24K disk.

Coming soon . . .

**LASER ANTS**® and **ASTRON IX**®

\*Indicates trademark of Atari, Inc.

All Syncro cassette programs are recorded complete on both sides with music track. All cassettes use high quality data tape and housing and each cassette is load tested.



**SYNCRO, INC.**

SOFTWARE DIVISION

30941 W. Agoura Road, Suite 200

Westlake Village, CA 91361

(213) 889-9508



do something better than can be done in any other format, or if they offer an entirely new idea. **Dogfight II**, unfortunately, falls a bit short of doing either.

Most home videogame systems include some type of plane-battle game. The characteristics of the planes may differ and the controls might be of differing formats, but the premise is the same.

*Dogfight II* is different from those games in only a couple of ways. First, there is the option of playing against a human or computer opponent. Then there is a pilot. He often bails out after his plane gets shot down and must be blasted out of the sky, lest he somehow gets back into his plane and live to fight again. The program also throws in a helicopter.

Many of the game's features involve the different mode-of-operation options. The game can be played with keyboard, one joystick, two joysticks or paddles. When playing against the computer, one player can provide opposition, two players can fight on the same team against the computer or both can battle each other *and* the computer. Then there is the custom mode where the gamer can pick jets or

helicopters, the speed of the game and determine the teams.

When using the keyboard, up to eight players can compete at once, if you can figure out how to get eight full-size bodies behind the same keyboard. In the keyboard version, the movement of the planes is the least satisfactory. For the first player, letter "Z" makes the plane bank left, "C" banks the plane right, "S" slows the plane down and "D" speeds it up. Letter "X" fires the gun. Using a key to bank in one direction is fine, but making the gamer use the opposite bank key to come out of the bank and then hit it again to bank in the opposite direction takes a lot of practice and makes for sluggish play.

When employing the paddle mode, you merely turn the knob in the direction you want the plane to fly and press the button to fire. You still must use the keyboard to increase or decrease speed. Joystick is the most effective. Pushing the joystick forward increases the speed, pulling back slows it down, pulling to the left banks the plane in that direction and pulling to the right banks it right. The button fires the gun. When a gamer's plane is hit, he must hit the button right away to bail out of

the craft and have a chance to fight again.

Players get 10 points for each plane and for each pilot shot down. If the computer bails the pilot out without a chute he falls very rapidly and is worth 50 points when hit. (If he bails out without a chute he won't return to his plane, regardless of whether he is it.) Rarely, he appears in a capsule. In that event, he's worth 100 points when hit.

For pilots who survive a round, the computer awards 10 bonus points for each plane that started the round against you. The display shows how many planes you have left (you begin with five), the point total, play level and the high score in the current mode since the computer was turned on. High scores from previous sessions aren't saved. An extra jet is awarded for each 1,000 points. The gun holds four bullets, which are reloaded at a rate of one per second. An itchy trigger finger can make the gun inoperable for a short time.

Overall, one would expect more graphics and more detail with a computer game that uses so much memory.

(Rick Teverbaugh)

Continued on page 135

# Looking For Electronic Games?

## ELECTRONIC GAMES RETAILERS

If you have trouble finding ELECTRONIC GAMES at your local newsstand or want to know where to send a friend to pick up a copy, the following will help. It's a list of retail stores across the country that carry the magazine.

### ARIZONA

All Systems Go, Tempe  
Niles Radio & TV Renter, Inc., Tucson  
Videocade, Tucson

### CALIFORNIA

Ancrona Ltd., Los Angeles  
Games, Van Nuys  
Gamesmanship, Santa Ana  
HW Electronics, Northridge  
Software Central, Pasadena  
Video 2001, Inc., Los Angeles

### DISTRICT OF COLUMBIA

Program Store, Ltd., Washington

### FLORIDA

Video City, Inc. Ft. Lauderdale

### GEORGIA

Young Entertainment, Inc. Atlanta

### LOUISIANA

Computer Shoppe, Metairie  
Video Connection, Metairie

### MASSACHUSETTS

Movies To Go, Newton

### MICHIGAN

Maxaron Corp., Warren

### MINNESOTA

Discount Video, Minneapolis

### MISSOURI

Liberty Sound, St. Joseph

### NEW HAMPSHIRE

Video Station, Inc., S. Merrimack



### NEW JERSEY

Ippys, Manasquan  
J&H Hobby Center, Vineland  
Magic Fountain, Hoboken  
Video Connection, Cherry Hill  
Video Track, Marlboro

### NEW YORK

Captain Video, New York City  
Captain Video, Pomona

Flatbush Video, Brooklyn  
Fran's Place, Conram  
Gold'n Video, Elmsford  
Kingsway Video, Brooklyn  
LVR Video, Manhasset  
Micro Center, Amherst  
Parkway Video & Electronics, Brooklyn  
Software Supply Intl., Inc., Niagara Falls  
Staten Island Computer Center, Staten Island  
Video Connection, Cedarhurst  
Video Hut, Inc., Flushing

### OKLAHOMA

On Line, Oklahoma City

### PENNSYLVANIA

Craftnut, Reading  
Games Unlimited, Pittsburgh  
Movies Unlimited, Philadelphia  
Parke T. Morrow, Inc., Erie

### TEXAS

Irving Video, Irving  
Games Peddler, Inc., Houston

### VIRGINIA

Big Picture, Arlington  
L & T TV Sales, Woodbridge

### WASHINGTON

Games People Play, Poulsbo

### WISCONSIN

Video World, Waukesha

### PUERTO RICO

Video Sonics, Hata Rey

### CANADA

KO Enterprises, Ltd., Oshawa

(ATTENTION: If you carry 25 or more copies of ELECTRONIC GAMES in your store and are not included in this list, please let us know so that we can include your store in our next issue.)



**MONEY-BACK GUARANTEE!** SEE PAGE 3

**5 EXCITING  
NEW GAMES!**

# US GAMES NEWS

## EARTH DOOMED?



### LONE SPACE JOCKEY FIGHTS BACK!

With every human attack weapon captured by alien forces and turned against Earth, surrender seemed inevitable...until you captured one of the alien attack saucers!

Screaming through the atmosphere, you cut forward and back, up and down to escape relentless alien fire-power. You blast back, firing direct-

able missiles into alien planes, tanks, and other obstacles.

Can you beat the aliens with their own machine? You can...if you're fast enough, if you're accurate enough, if you're good enough.



*Can you beat the aliens at game level 16?*



# ANDROID RAIDERS ATTACK!

## HOT GUNNER COULD SAVE CITY!

With attack choppers dropping android commandos and fighter-

bombers delivering payload after payload, our city would be destroyed by now if it weren't for one brave gunner... you.

Only your quick eye and quicker trigger finger can hold off wave

after wave of android parachutists. Only your skill can keep them from tunneling under the city and taking you out. The game is Commando Raid, and you're the city's last hope.

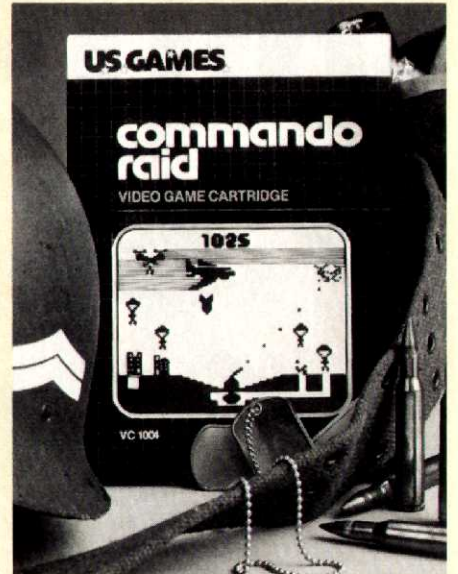
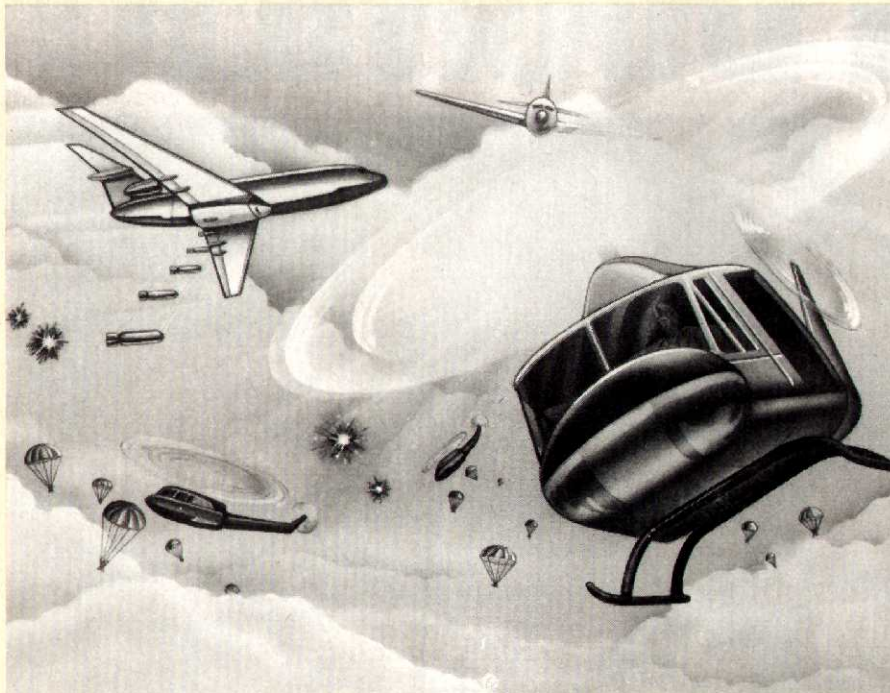

The action gets faster with each commando attack wave!



# ZAPPER A FAST BLAST!

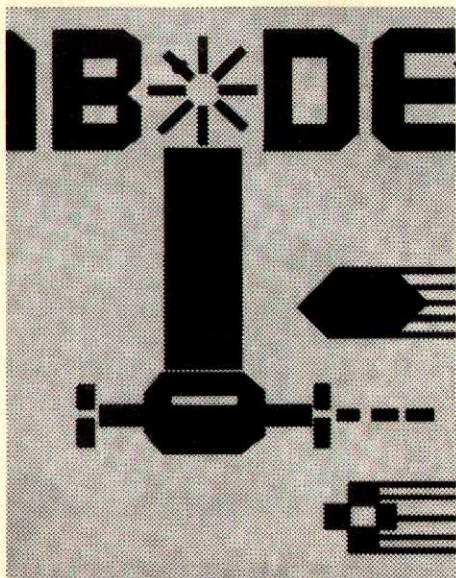

## HOT GAME CHALLENGES THE BEST!

Just when you think you've thought fast enough, you've got to think faster! You've got to fire left and right to zap deadly asteroids...one hit by the Doomsday asteroid and your saucer blows!

But that's just defense! To win you've got to fire overhead with incredible skill to blast away the letters of the alien's language. And it will only work if you follow the computer's lead. Can you beat Word Zapper through all 24 games? Can anybody?



Why is Ronald Evans smiling? Did he beat the zapper?



# FIERY DISASTER AVERTED!

## BOLD FIREFIGHTER SAVES HUNDREDS!

It's a race against time and the fury of fire that can destroy innocent occupants...and you! You're the firefighter...do you

have the skill and strategy it takes to beat Towering Inferno?



It was the worst fire you'd ever seen...a high-rise going up like a torch. With a different fire-filled maze on every floor. And hundreds with no way out...unless you could get them out to the rescue chopper.

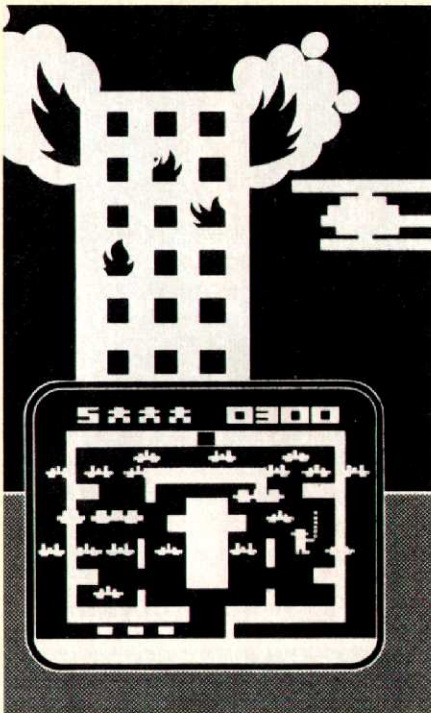

Relive the movie in this challenging maze game!



Special introductory offer

**YOU'LL LOVE  
OUR GAMES  
OR WE'LL  
BUY 'EM BACK**

Yes, video fun is now guaranteed by U.S. Games. Because if you're not happy with any of our games—for any reason—just return it in its original carton postmarked within 5 days of purchase with your dated receipt. We'll send you a check for your full purchase price. See your dealer or check newspaper ads for complete guarantee details. Offer expires December 31, 1982.

**So if you want  
your Atari action  
guaranteed hot...  
look for the name**

**US GAMES**

© 1982 U.S. Games Corporation

Cartridges are manufactured for the ATARI Video Computer System Model 2600 by U.S. Games. ATARI, Video Computer System, and 2600 are trademarks of Atari, Inc. U.S. Games is not affiliated with Atari, Inc.

# MISSING PERSON MYSTERY SOLVED!

**ENTIRE FAMILY CAUGHT UP IN SEARCH.**



Four different rooms with lots of sneaky places to hide.

It seems simple enough...somebody disappears, and you find them. But this is a spooky video world, with electronic hidey-holes that happen where you least expect!

You can seek a friend or family opponent...or take on the computer! You've got to beat the clock, or your Sneak 'N Peek opponent has you dead to rights!





# STARTER



# LEVEL

## Striking Back—At Stars and the Empire!

By FRANK TETRO JR.

### STAR STRIKE

Mattel Electronics/Intellivision

In *Star Strike*, a "trench" style space battle reminiscent of the assault on the Death Star from *Star Wars*, it is your mission to destroy an alien station planning to annihilate the Earth. There are a quintet of red enemy outposts, each of which must be wiped out in order to stop the station from doing its thing.

As you maneuver down the trench, you will be continually assaulted by pairs of enemy scout ships who attack, initially, from the rear, then overshoot your craft in hopes of escaping. Each time they hit your ship, the damage grows worse until control is ultimately destroyed and you crash. Accidentally slipping into the walls of the trench will instantly end the game in a blaze of fiery glory.

If you should miscalculate and miss bombing an outpost, all is not lost. The station will continue to rotate, and that same outpost will soon revolve into

view once again. However, if the Earth is in line with the trench and you miss the outpost—oops!—the enemy will launch their planet atomizer and our beloved home planet, ending the game with a bang.

The game begins with 8,000 points, and the score decreases rapidly as you go. Hitting an enemy ship adds 250 points to your score. As the game begins, you will be instantly attacked by a pair of scouts. Remember, when you are behind these ships you can't hit them, only get out of their way. The best evasive action involves circular movement, and random, side-to-side weaving. But keep moving at all costs!

Once the ships turn light blue, they have moved in front of you and can be gunned down. Get behind them and start blasting, keeping in mind that all shots head toward the center of the trench (consult your instruction book for complete details). If the two ships are moving away and are out of the trench, leave them be. The enemies'

strategy is to pull you from the trench so you will miss the outpost when it appears. Once the enemy ships are destroyed or exit the screen, another pair will appear and should be dealt with in the same manner.

At the sound of the outpost warning klaxon, immediately disengage from the attack with the enemy ships, and fly to the lowest possible position in the trench. You will know you are low enough if your pink shadow is nearly touching the bottom of the ship. When the red outpost appears about one-half to three-quarters inches in front of the ship, (depending on your TV set), drop a bomb. Whether or not you hit, get out of there quickly.

If you remember which posts you hit and which ones you miss, the game will be made considerably easier. If you know the upcoming post is destroyed, you can ignore the warning buzzer and concentrate on destroying enemy ships for more points.

Keep in mind that whoever is in the rear has the firing option.

### THE EMPIRE STRIKES BACK

Parker Brothers/VCS

This epic video simulation of the opening battle sequence from George

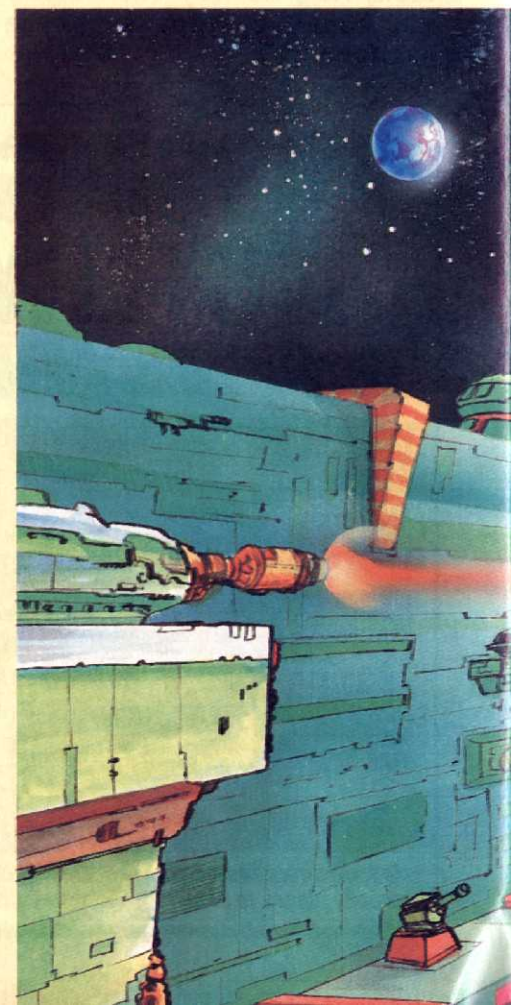



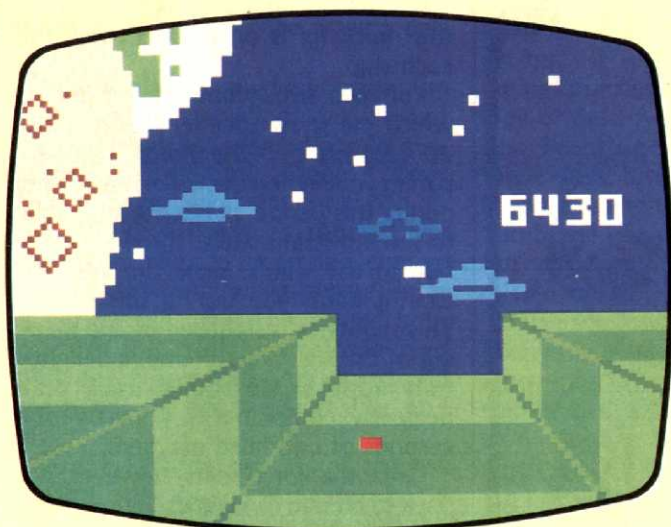

STAR STRIKE

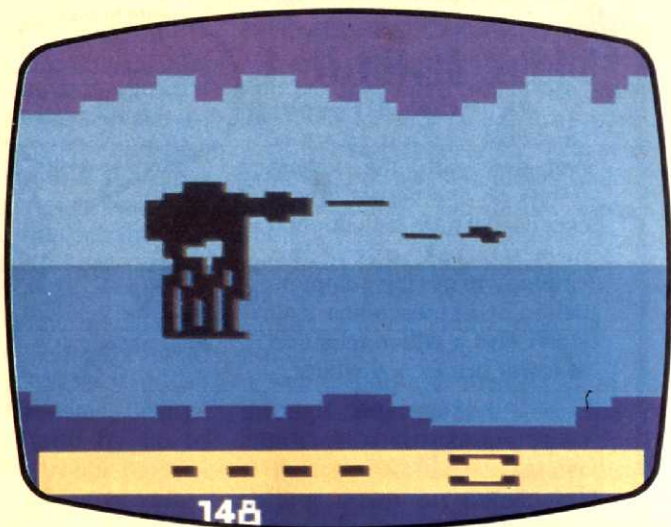

THE EMPIRE STRIKES BACK

Lucas' film of the same title, captures all the grandeur and excitement of the original. It is set on the ice planet Hoth, where the rebels have established a base station. Darth Vader, Dark Lord of the Sith and hatchet man for the evil emperor, has discovered their presence and dispatches a column of AT-AT's—the elephantine "Imperial Walkers"—that move inexorably toward the rebel power station.

The gamer takes the role of Luke Skywalker, sole hope of the downtrodden rebel alliance. Boarding

your snow speeder, you take off after the phalanx of mechanical dreadnoughts in an attempt to hold them off for as long as possible while the rest of the base is evacuated.

The snow speeder is controlled via the joystick. The ship is raised or lowered by moving the controller shaft vertically, and thrust is applied in either direction depending on whether it is moved left or right. The action button fires the front-mounted cannon in the direction the ship is facing.

As mentioned previously, these

AT-AT's are not exactly fish in a barrel, despite their enormous size. It requires 48 hits to the body of an All-Terrain Armored Transport to destroy it. Each hit is worth a point and every eight blasts on target changes the Walker's color to indicate mounting damage.

Your snow speeder can absorb up to five hits—dependent upon how much the computer likes you. Once the ship is damaged, however, it turns white and you must carefully pilot it into a canyon where it will be instantly repaired—unfortunately, however,

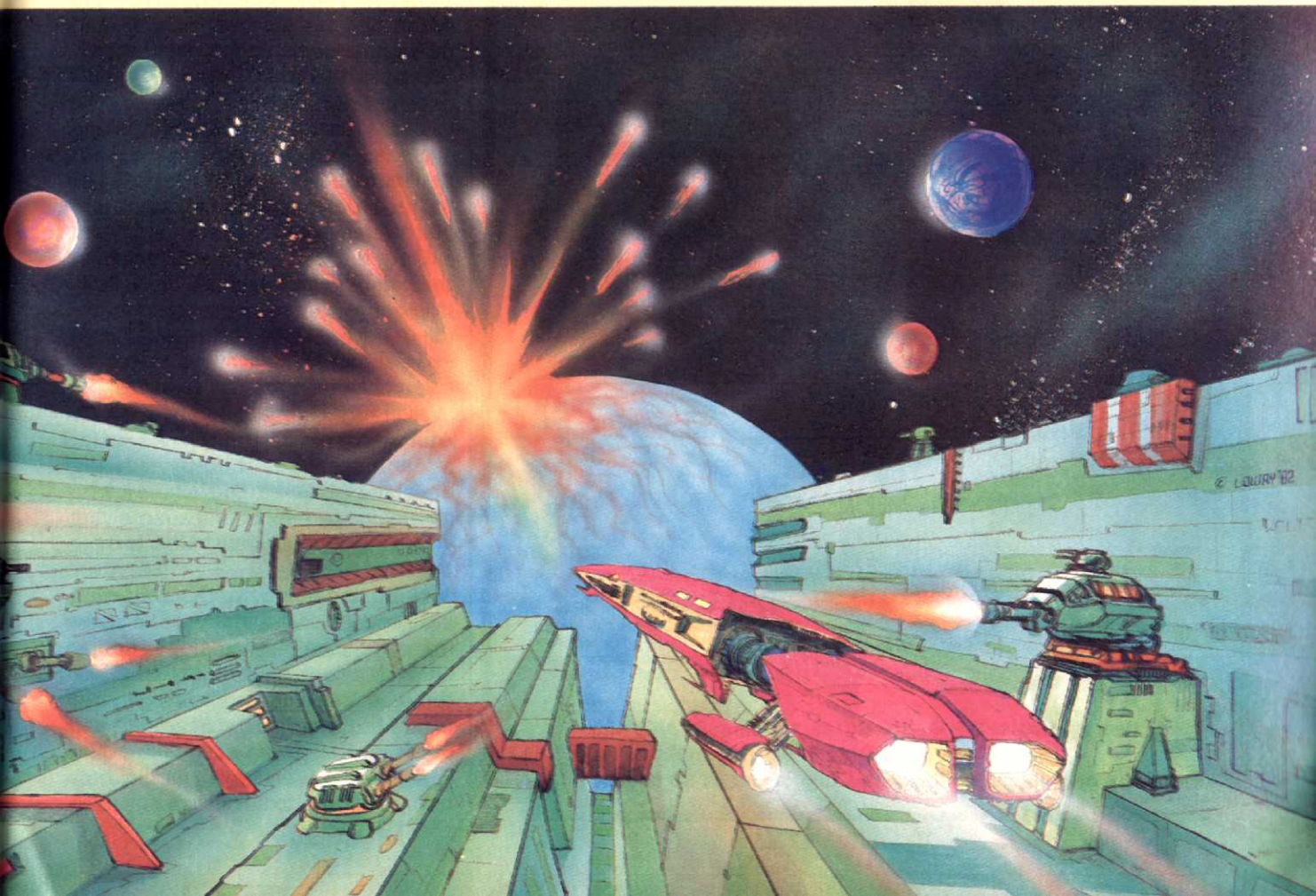



# Video Unlimited

We have all your favorite video games cartridges with the lowest prices on any planet. If you don't see it here, call our 800 number for our free catalog to get the complete listing of all our games. You won't find a wider selection at lower prices any where.

"Video Unlimited offers" savings that are out of this world



## ASTROCADE

MODEL	DESCRIPTION	COST
2015	Pirates Chase	26.49
3006	Bowling	26.49
3007	Soccer	26.49
2017	The Incredible Wizard	26.49
2018	Solar Conqueror-Fall	26.49
2019	Cosmic Raiders-Fall	26.49
4005	Coloring Book-July	28.99
5004	Conan The Barbarian Fall	28.99
5005	Artillery Duel-Aug	28.99
4003	Music Maker I-Fall	48.99
4005P	Color Book W/Light Pen	48.99

MODEL	DESCRIPTION	COST
2015	Pirates Chase	26.49
3006	Bowling	26.49
3007	Soccer	26.49
2017	The Incredible Wizard	26.49
2018	Solar Conqueror-Fall	26.49
2019	Cosmic Raiders-Fall	26.49
4005	Coloring Book-July	28.99
5004	Conan The Barbarian Fall	28.99
5005	Artillery Duel-Aug	28.99
4003	Music Maker I-Fall	48.99
4005P	Color Book W/Light Pen	48.99

## ATARI

CX2658	Math/Grand Prix-July	19.50
CX2615	Diamonds to Demons	19.50
CX2659	Raiders of the Lost Ark-Dec	21.99
CX2650	Berzerk-Sept	25.49
CX2655	Yar's Revenge	25.49
CX2656	Adventure I-Oct	28.99
CX2657	Adventure II-Nov	28.99
AX-015	Chopper Command	25.99
AX-016	Star Master	25.99
AX-017	Megamania-Sept	25.99
AX-018	Pitfall-Sept	25.99

## Apollo/Atari

AP1001	Skeet Shoot	18.99
AP2001	Space Chase	18.99
AP2002	Space Cavern	18.99

## Coleco/Atari

CAT2451	Donkey Kong-Aug	25.49
CAT2454	Zaxxon-Oct	25.49
CAT2455	Turbo-Oct	25.49

## Commaid/Atari

CM003	Cosmic Swarm	29.99
CM004	Room of Doom-June	29.99
CM005	Mines of Minos-June	27.99

## Data Age/Atari

DA1001	Encounter at L-5	27.99
DA1002	Warlock	27.99
DA1003	Sssnake	22.99

## Imagic/Atari

1A3000	Trick Shot	19.49
1A3200	Demon Attack	19.49
1A3201	Star Voyager	19.49

## Mattel M-Network/Atari

5664	Froos & Files	25.99
5658	Football	25.99
5659	Space Attack	25.99

## Parker Bros./Atari

PB5050	Empire Strikes Back	34.49
PB5300	Frogger-Aug	34.49
PB5310	Amidar-Sept	28.99

## Spectravision/Atari

SA201	Gangster Alley	28.99
SA202	Planet Patrol	28.99
SA203	Cross Fire-Aug	22.49

## COLECOVISION

COL2411	Donkey Kong-Aug	29.99
COL2413	Turbo (W/control)-Aug	69.99
COL2415	Space Fury-Nov	69.99
COL2417	Venture-Aug	69.99
COL2419	Mouse Trap-Sept	69.99
COL2422	Football-Oct	29.99
COL2423	Baseball-Oct	29.99
COL2433	Lady Bug-Oct	29.99
COL2434	Cosmic Avenger-Aug	29.99
COL2435	Zaxxon-Aug	49.95
COL2439	Las Vegas-Oct	49.95
COL2441	Tunnels & Trolls-Oct	49.95
COL2442	Horsereading-Oct	29.99
COL2443	Smurf Action-Aug	29.99
COL2445	Carnival-Aug	29.99
COL2446	Victory-Sept	29.99
COL2447	Space Panic-Sept	41.49

## MATTEL INTELLIVISION

5301	Frog Bog	20.49
5304	Reversi	20.49
3408	Sub Hunt	28.49
5391	Tron Deadly Disc-Aug	28.49
5392	Tron Mazatron-Sept	28.49
1818	Sea Battle	28.49
3410	Dungeons & Dragons	28.49
5136	Space Hawk	28.49
5149	Utopia	33.49
5161	Star Strike	33.49
5305	Night Stalker	33.49
5637	Lock 'N Chase-Sept	33.49

## Coleco/Intellivision

CMA2471	Donkey Kong-Aug	45.99
CMA2473	Turbo-Nov	45.99
CMA2479	Mouse Trap-Aug	33.99

## Imagic/Intellivision

IM7200	Demon Attack-Oct	29.99
IM7203	Atlantis-Oct	29.99
IM7601	Micro Surgeon	35.99

## ODYSSEY 2

W/AJ9400		
BB7600	Odyssey 2 Game	149.95
701705-7	TV/Game Switch	14.99

**HOW TO ORDER BY MAIL.** For prompt shipment, send money order, certified check, cashier's check, MasterCard, Visa, (include card number, interbank number, expiration date, and signature). There will be a two-week delay for check clearance. Shipping and insurance charge is \$1.50. Ohio residents add 5% sales tax.

Video Unlimited P.O. Box 38145, Cincinnati, Ohio 45238

1-800-543-7239 In Ohio 1-800-244-9990

Send or call in your order and ask for our Free catalog

this quick fix is only good twice for each ship.

For each two-minute period during which the snow speeder eludes a hit, 20 seconds of "The Force" accompanies you. When the Force is with you during this period, players will be able to fire indiscriminately, throwing caution to the winds, since the Walkers cannot harm you during this phase. This sequence is signalled by the playing of the *Star Wars* theme, a delightfully appropriate sound track that perfectly compliments your twenty seconds of unbridled mayhem.

Once the Force splits, however, it's back to hit and run tactics. Remember, the Walkers can fire in a 360° range, enabling them to clip you from any angle, no matter how unlikely it may seem.

At the base of the screen is a radar tracking device that allows you to monitor the progress of the five Walkers as they near the power installation. As the game begins, head for the lead AT-AT instantly. Though it isn't imperative, flying low is generally a sound strategy. Once you reach the first Walker, start to blast away as fast as your little trigger-finger can twitch. Avoid getting too close at the beginning, hanging back until the AT-AT fires its first round. Duck it, and return to your previous position and re-commence firing. Repeat this process over and over. Eventually, you'll develop a "feel" for when the Walker's getting ready to fire, making avoidance all the easier. Blow your timing, however, and the big guy will re-track you, lock on and blow you into *Star Wars* Heaven.

Once the lead Walker is damaged to the point where he has turned yellow, *stop firing!* This color change indicates the AT-AT will be destroyed within eight shots. Keep in mind that each color change not only weakens the Walker further, but also *slows it down*. At level yellow the AT-AT is at minimum speed, thereby slowing down the Walkers in line behind it who are unable to pass their leader, giving you more time in your battle to save the base.

Next, move on to the following Walker and deal with it in the same manner. Scan the radar at regular intervals, however, in order to monitor the lead Walker's progress. When it makes the generator, spin around and polish it off. But make certain that the AT-AT's new leader is immediately brought down to minimum speed in



order to slow down the trailing column.

When playing a game using the "smart bomb" variation, stay clear of the bomb hatches as smart bombs may launch at any time. Once it does launch, begin flying straight in one direction. If it looks as though the speeder is going to be totaled, change direction abruptly while pulling up or down on the stick. This should both confuse the tracking explosive and provide a bigger lead. Stay ahead, and the bomb will eventually give up and disappear.

Another helpful hint: Bomb hatches periodically open, indicated by a glowing, red block. Hit one, and the Walker is instantaneously obliterated, regardless of previous damage inflicted before the blast.

One final caveat, however—when the "Force" is with you, disregard all strategy tips and head directly for the Walker posing the greatest danger. Get in line and start hitting the big, metal monstrosity with everything you've got. Don't stop until the smoke clears and the Empire's deadly toy is just an unpleasant memory. After all, Ben Kenobi would have wanted it that way . . .

## COSMIC AVENGER

Coleco/ColecoVision

**Cosmic Avenger** is a horizontally-scrolling shoot-out along the lines of such arcade favorites as **Scramble**, **Super Cobra**, **Defender** and . . . *Cosmic Avenger*, itself! The game is actually a home adaptation of the coin-op by Universal that allows players to pilot bomb and laser-equipped fighter jets over three distinct landscapes. The ship must first breach the alien city, including its buildings, missile launchers and searchlight, and move over a tank track and through an underwater blast-up with submarines, heat-seeking missiles and depth charges.

The trick here is to fly at absolute lowest-level speed and hug the landscape. Staying in the air makes your ship into a sitting duck. Speed up and climb only to avoid otherwise certain death.

In the cityscape scenario, bombs are much more effective than lasers, but since the ColecoVision uses a joystick controller with *two* action buttons, it becomes possible to fire both weapons simultaneously.

Staying low has several advantages: most of the enemy's weapons are aimed skyward, for example, and

these are all thwarted by hugging the ground. It also allows—with some timing practice—an all but sure-fire way of destroying the missile launchers. Breezing along just over the tower-silos, drop a bomb a heartbeat before passing directly overhead. This bomb will not only take out the silo, but any just-launched heat-seeking missile as well.

On each level of play, however, a joker invades the deck—in the form of a hovering attack ship. Whenever this ship comes flitting into view, diverge from normal tactics and fly up to engage it—otherwise you'll be facing enemies beside and above you.

On the tank course, drop right to the ground - except, of course, to take on

enemy saucers. Otherwise, remain on line with your target's hindquarters. You can then either obliterate oncoming shells, or simply leap-frog them.

Underwater, as on the tank grounds, bombs are a luxury and your laser becomes your prime weapon. There are no saucers underwater, but you must maneuver through a twisting sea cavern and destroy targets almost entirely horizontal to your position.

Some players prefer to streak through the scenarios—a fruitless approach that garners few points. With each round, the cityscape rises, cutting down on maneuverability—but low-flyers will find this makes play even easier!





# PASSPORT TO

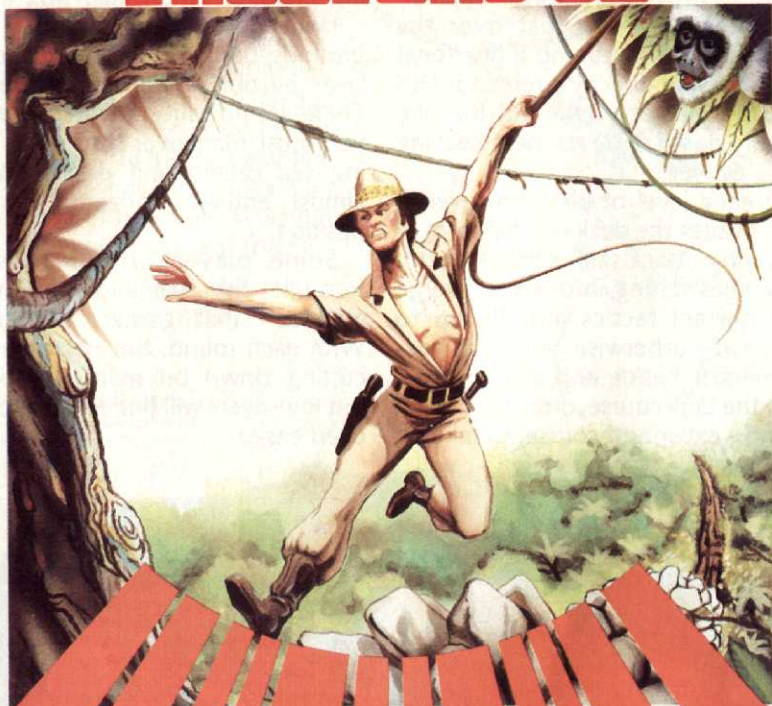

# ADVENTURE

## Solve the Crime and Beat the Deadline!

By ARNIE KATZ

### DEADLINE

Infocom/Apple II, Atari 400&800/48K disc:

You take a deep breath as you gaze upon the Robner mansion, so peaceful in the morning light. Yet appearances can be deceiving. This is anything but a peaceful home.

Its owner, Marshall Robner, has been found lying on the floor of his library, dead. It looks like a simple overdose of Ebullion, for the police have found a few tablets of the substance lying around the scene. But could it have been, in fact, a murder?

Warren Coates, the family lawyer, is one who is suspicious. Even though Coates hasn't got any concrete evidence, he has written to your superior, the Chief of Police, asking for a more

thorough investigation of the events surrounding his client's recent demise.

The Chief, perhaps mindful of the Robner family influence, has assigned you to pick up the threads and continue the probe. To that end, you've gotten permission to poke around the Robner home for 12 hours. If you can't piece together the clues and build an airtight case against the perpetrator of this subtle and ingenious crime, the Ebullion overdose story will have to stand as the official finding in the case. And a murderer will walk free.

That's the gripping situation that confronts the player in *Deadline*, the first of a new series of adventure programs for popular microcomputers. Infocom has already drawn raves for its

fantasy quests, *Zork I* and *Zork II*, and this text-only mystery challenge proves that the company isn't afraid to depart from the tried-and-true adventure game formula.

Actually, *Deadline* is one of the most innovative adventure programs released this year, despite the absence of visuals. Written in machine language, it has an extensive 600-word vocabulary and can even understand full-sentence commands from the human detective. That's a big improvement over the terse "verb/noun" two-word orders most other adventures require.

Even more important, the characters who populate the game seem to think, feel and act in a lifelike manner. All the while the player is trudging from room to room looking for evidence, potential suspects are going about their private business. If the detective isn't at the right place at the right time, it is possible he or she will fail to see a person enter a room or perform some other action that would help break the case.

Time, then, is crucial in this game. The excellent eight-page instruction booklet reflects this by letting players know how to let game-time pass while they wait for the appearance of some suspect or for some anticipated event to transpire. For instance, the human inspector knows, from a letter which is included with a packet of papers and evidence Infocom provides for the tactile-oriented sleuths, that the lawyer will be reading the will at noon. If it's only 11:15 a.m. and there's nothing else you need accomplish before then, you can run the clock ahead with a single "Wait until 12:00" command.

An important feature of the instruction book is that it gives a pretty decent vocabulary list as well as guidelines for performing various tasks. Many players experience great frustration in other games when they know what has to be done but can't figure out how to communicate their idea to the computer. This very rarely happens in *Deadline*, making the flow of play much smoother.

As the inspector in charge of the investigation, you do not have to work alone. To begin with, Detective First Class G.K. Anderson has conducted a preliminary search for evidence and has interviewed all of those who could



have been involved in any crime. Meanwhile, Medical Examiner Xaviera Hockmuller has been doing her work as well. You've got a complete report on the body.

Now that you're on the scene, Sergeant Duffy performs as your faithful aide. When you want a substance analyzed by the police laboratory or learn the owner of a set of intriguing fingerprints, Sgt. Duffy will carry out the legwork.

Of course, you will have to twiddle your thumbs a bit while he's going to and from the lab, but it's still far less time-consuming than having to make the round trip yourself. Remember, time is of the essence!

There's no denying that *Deadline* is a lot more complicated than the usual hack-and-slash sword epic. For those who want to analyze the proceedings at their leisure, entering the "Script" command will cause everything that flashes on the screen to get typed out by a printer connected to your computer.

Another important option is the ability to suspend a game in progress for resumption at a later time. The process is simple. After entering the "Save" instruction, the display will prompt the computerist to insert a blank disk and then asks the operator to enter the position on the disk where the game-in-progress should be stored. It is possible to store eight different games simultaneously on the same disk, so that more than one amateur detective can try to unravel the tangled web without ruining someone else's case. Since *Deadline* is fairly difficult, most players will be making repeated use of the change to

rest and reflect between crucial moves.

The time element endows *Deadline* with a surprisingly high excitement level for a game which has virtually no overt violence and relatively little action. As the minutes tick past, the pressure to achieve some sort of break-through becomes intense. Of course, a wise detective doesn't let his nervousness turn into meandering and desperate interrogations of the suspects, because that makes bringing the killer to book just about impossible. Offend a witness in *Deadline*, and he or she

can become very, very hostile. Needless to say, an angry person imparts very little useful information to an investigator.

*Deadline* is a landmark in computer gaming history as well as a mentally stimulating contest of the highest magnitude. Although it would be very nice if, at some future point, Infocom authorized a revision that included high-resolution graphics, this

text-based disk can hold its head high in any company. An outstanding achievement in computer software.

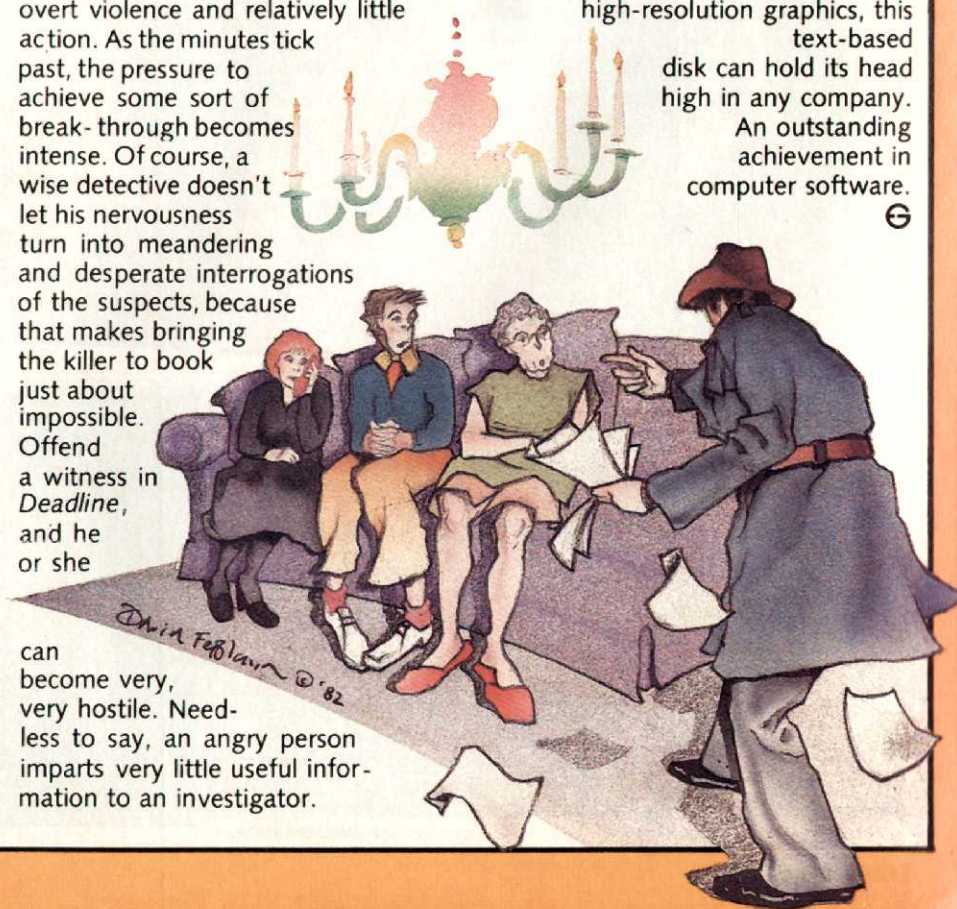
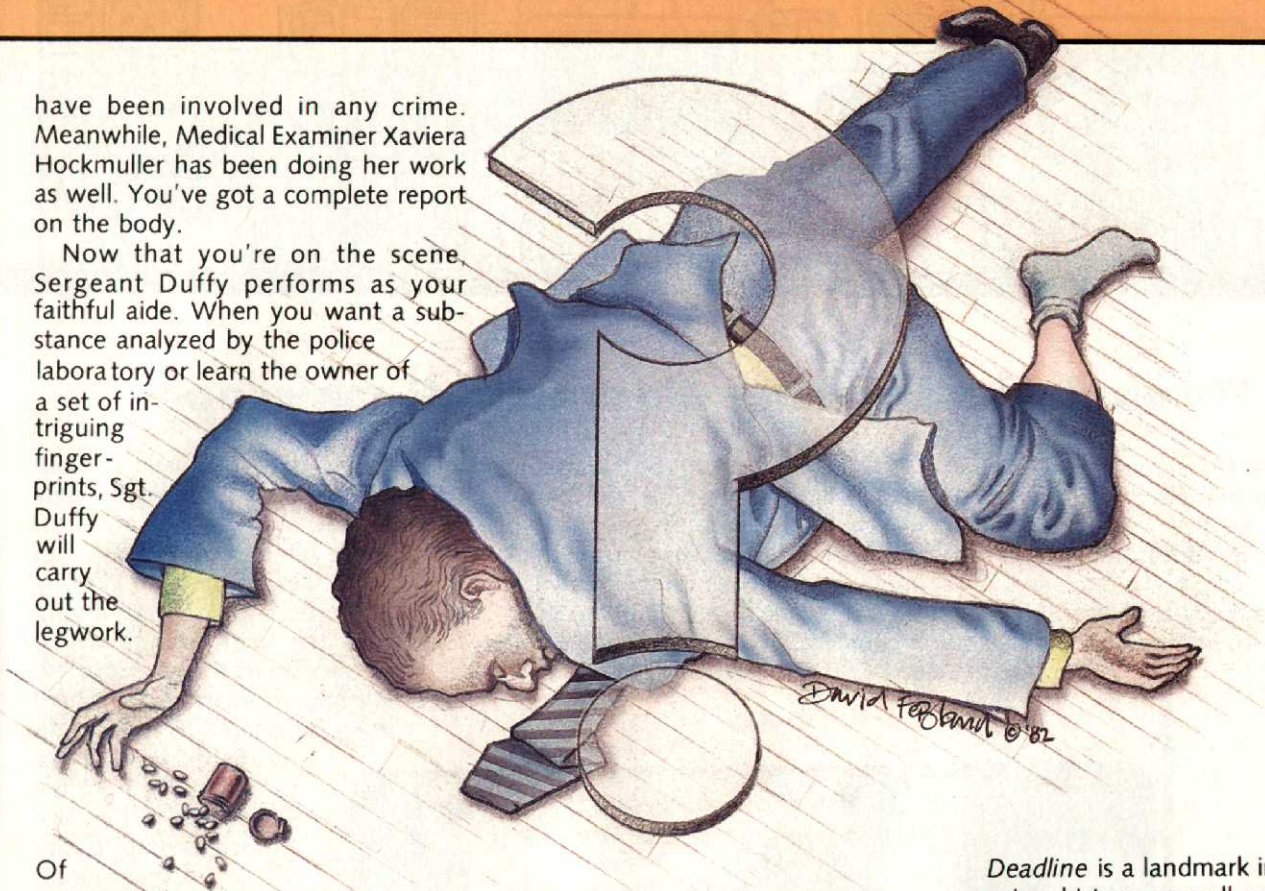



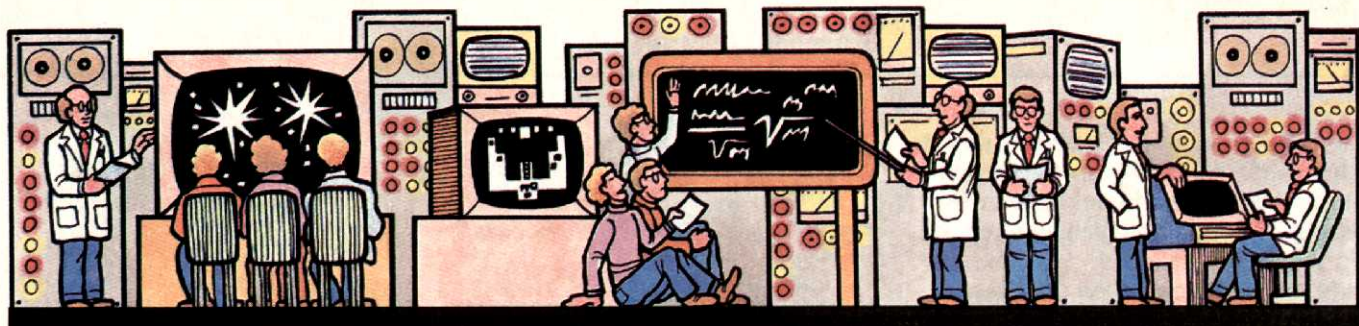

## Through the Looking Glass with Beamscope

**E**G gave big-screen television a fairly thorough going-over in a July article entitled "Videogames Go King-Size". In concentrating only on projection sets, however, we overlooked a radically different approach to making your home arcading bigger and better.

The device is called the Beamscope, and in light of its price and performance, it's a device that ought to be worth a look by gamers who are thinking big. It has been on the market for the last couple of years, but recent improvements in its design make it quite suitable for electronic game-lovers

who want a larger playfield without the full expense of a correspondingly larger TV set.

For those who are unfamiliar with the product, Beamscopes are virtually flat, large rectangular magnifying lenses. For use with table model or portable televisions, they are located, via spring-tipped metal rods, in front of

the picture tube. By moving the lens approximately 6- to 8-in. away from the screen, the picture size increases up to four magnifications.

Manufactured of ultra-hard, optically coated, clear acrylic plastic, these fresnel lenses are framed by a thin, unobtrusive band of polished metal. Some future models are expected to be framed in black-colored aluminum to further enhance their appearance.

Currently there are three models of Beamscopes available, but by the time you read this a fourth should be joining the roster. With these four sizes



(Left) Normal TV screen running ColecoVision's Ladybug videogame. (Center) The same screen with the Beamscope laid flat up against it. (Right) Beamscope moved slightly away from TV set. The Beamscope is capable of even greater magnification, but these photos were shot from a fixed position.

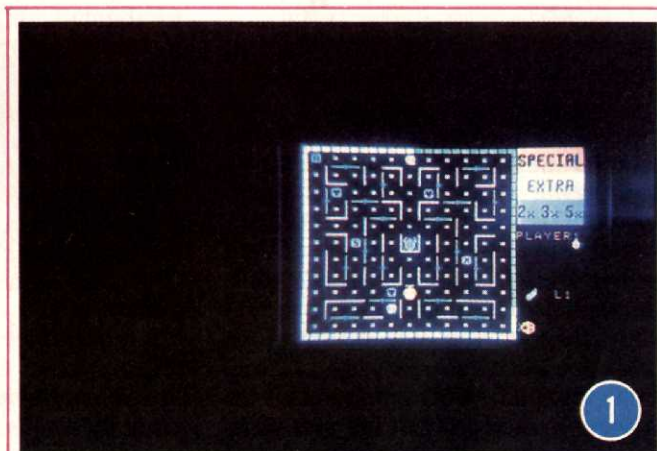



# TEST LAB

almost every TV screen will be able to have a Beamscope.

Before detailing performance, it must be stated that Beamscopes are not a gimmick. While many video electronics critics have frowned upon the product in the past, this writer has formed a strong positive opinion while living with two of them for over six weeks. It's not that Beamscopes are faultless, it's simply that over time some of the immediate annoyances have faded into memory. Moreover, a brand new lens design overcomes many of the problems associated with earlier models of the product.

To get specific, the original design caused haloing and prismatic colors to appear around the perimeter of the program being viewed. This is less true for videogames, since their playfields rarely take up the entire screen area. In addition, after watching normal television programming for the first time, some viewers reported a slight dizziness and headache.

Both of these phenomena are well known to those at Beamscope. They readily acknowledge that such problems did exist in the past but that most people got over them quickly. This proved to be an accurate statement. By the second day, we no longer felt any side effects from extended viewing

through the Beamscope. The haloing, however did not go away; we simply learned to live with it. After awhile, we hardly noticed it at all. The new lens design eliminates the haloing effect and prismatic color borders so much of this discussion is academic.

An important benefit of the Beamscope is that, through its extremely clever design, it causes no loss of picture clarity or brightness even though it greatly magnifies the size. This is a result of using a fresnel design which places concentric rings emanating from the center of the lens to its outer perimeter. A more common use of this kind of lens is seen in the viewfinder of just about every standard 35mm SLR camera.

The fresnel rings used to be cut at a steeper angle, which caused refractions of the light coming from the picture tube being magnified. The new design utilizes a less severe cut and so causes the lens itself to absorb almost all of its refracted light. This coupled to an optical coating has eliminated optical ring-around-the-collar so to speak.

In a few cases, however, some reflections are noticeable near the center of the picture. Fortunately, they are short-lived and in a practical sense, virtually non-existent. The only light-

ing consideration is that putting lamps near the Beamscope can cause some reflections. Of course, nobody recommends lighting your TV picture with lamps anyhow.

In essence, Beamscopes are incredibly good news for people who desire a larger picture but don't want to make a large investment to get one. We honestly feel that almost any gamer will find nothing but joy in the new lens design and that's saying a great deal.

As we noted in our earlier piece game playing is more pleasurable if you can sit back and relax away from, and not hunched over, the screen. With extension cords available for most game controllers you are no longer a prisoner of a five foot playing radius. If you own a console TV you can obtain an eminently playable 41-in. diagonal picture. By pulling the Beamscope even further from the TV you can continue to magnify the center portion of the picture until a pixel fills the room, figuratively speaking. Of course nobody in their right mind would want to do that — would they?

For those with 12-in through 15-in. TVs, the TS-25 will provide a 25-in diagonal picture representing a magnification factor of 261-400%. At a retail cost of \$59.95 you've got to try it

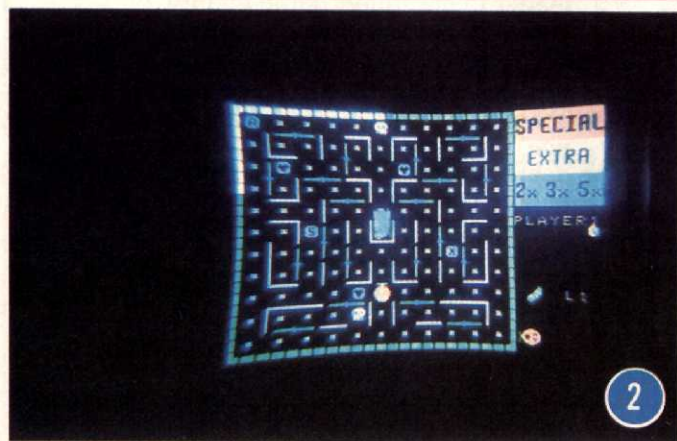



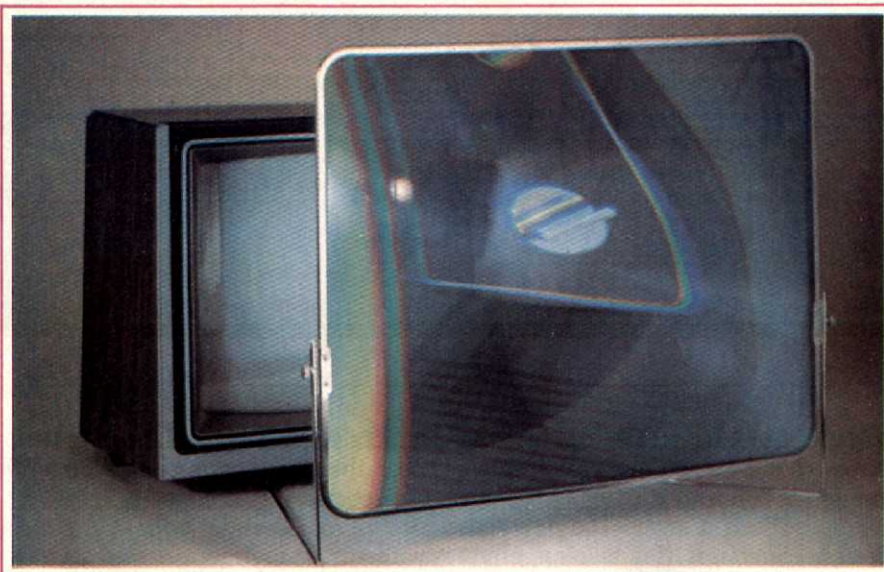

The Beamscope can turn an ordinary TV picture into a big-screen image

first, and then make the purchase.

The TS-30 handles TVs with 17-in. through 21-in. pictures and costs but ten dollars more. Swivel mounts are available for both Beamscope models and hold both the TV set and the Beamscope in proper viewing position. These accessories aren't mandatory unless you are prepared to view the set from a single, immovable position. The

units cost but \$19.95 and \$21.95 respectively and are well worth this moderate investment.

The TS-41 is for consoles and retails for \$219.95. It provides a 41-in. diagonal picture which is mighty big if you haven't seen one before.

This model is the first to feature the new lens design and one of two (the other is the TS-30) we have pictured in

this month's "Test Lab".

For the well-heeled it is also available, as shown in a wood grained frame, as the TS-41D complete with dust cover and cleaning kit for \$329.00.

The bottom line. After years of hearing that Beamscopes are gimmicks, this writer has lived with two of them for some time now and wouldn't be without them. How else can you enjoy the benefits of a giant screen Trinitron picture with virtually no sacrifice in image quality or integrity?

That is how much we like and believe in this product.

We are eagerly awaiting the 10-in. model made for TVs with 5-in. pictures. This single unit will open up a whole new world of practical portable video products.

While no magnifying lens may ever be perfect, the newly designed Beamscopes are good enough for almost anybody and represent a tremendous buy for those who cannot afford, or simply disdain, projection TV. They are, in some cases, preferable to projection TVs in that they can be used with no diminution of room lighting.

At the very least it's worth a visit to a local retailer to see one in action. 

## Q: What is the hardest thing in the world? A: Tearing yourself away from an EPYX game.



Nobody but nobody builds more lasting playing value into their computer games than EPYX.

EPYX—computer games thinkers play. EPYX—producers of award-winning games (including "Crush, Crumble and Chomp"; "Dragon's Eye"; "Temple of Apshai"... and dozens of other thinking games.) For Atari,\* Apple,\* Commodore,\* Radio Shack,\* and IBM\* personal computers. EPYX—the leader in computer game quality, creativity, innovation.

You will love them all. Guaranteed. Write or phone for our latest catalog; it's absolutely free... we even pay the postage. Or stop in at your favorite computer dealer. He should have a supply of catalogs and he can also show you some of those marvelous EPYX games in action.

\*The trademarks, respectively, of Atari, Inc.; Apple Computer, Inc.; Commodore International; Tandy Corp.; International Business Machines. And EPYX is the trademark of Automated Simulations, Inc., just so you don't forget.



**AUTOMATED SIMULATIONS**  
1043 Kiel Court  
Sunnyvale, California  
(408) 745-0700



**NEW**

FERNANDO HERRERA'S

# ASTRO CHASE

"THERE IS NO ESCAPE!"™



COSMIC SQUEEZE™  
by Jason Pomerantz  
graphics by Fernando Herrera

### Fernando Herrera Strikes Again!

In **ASTRO CHASE**, his first program since winning the ATARI® STAR AWARD, Fernando delivers: Fast, Super, ARCADE GRAPHICS ★ 100% MACHINE LANGUAGE ★ SMOOTH SCROLLING UNIVERSE (different for each new game) ★ AWESOME SOUND EFFECTS ★ NON-STOP ACTION ★ MULTI-DIRECTIONAL FIRING ★ INTELLIGENT ENEMY ATTACK SHIPS ★ SINGLE THRUST PROPULSION™ ★ INVISIBLE FORCE FIELDS ★ MULTIPLE SKILL LEVELS ★ Many more INNOVATIVE and UNIQUE features.

FOR THE

ATARI®  
HOME COMPUTER  
**32K**

"THERE IS NO ESCAPE!"

Ask for FIRST STAR SOFTWARE at your local dealer.  
Retail and Distribution inquiries invited.

**DISK  
AND  
TAPE**  
\$29.<sup>95</sup>\*

(CARTRIDGE COMING SOON)

"When being first counts...we're number one"

To Order:  
Call TOLL FREE 800-223-1545  
nationwide except in New York  
phone 212-889-1073



When using your MASTER CARD or VISA please have ready: your card number & expiration date. Send your check or money order for \$29.95\* plus \$2.00 shipping and handling to: First Star Software, Inc. 22 East 41st Street New York, NY 10017

When ordering, please specify DISK or TAPE  
\*New York residents please add 7% sales tax.

**FIRST STAR**  
SOFTWARE INC™

ATARI® is a registered trademark of Atari, Inc.  
Single Thrust Propulsion™ is a registered trademark of First Star Software, Inc.  
ASTRO CHASE, "there is no escape!"™ is a registered trademark of First Star Software, Inc.  
COSMIC SQUEEZE™ is a registered trademark of First Star Software, Inc. ©, 1982 First Star Software, Inc.



# Pack Up Your Video-Game in a Suitcase and Take It With You Anywhere! EG's Electronic Wizard Gives Gamers the Lowdown on the World of Portable Videogames!

The inside of the Southern Case has molded, foam-cushion cut-outs in order to accommodate the modular components

Toshiba TV set in its 4 by 5 format is the perfect suitcase-sized monitor for this system

Individual nooks have been sculpted from the foam interior to hold several extra game cartridges

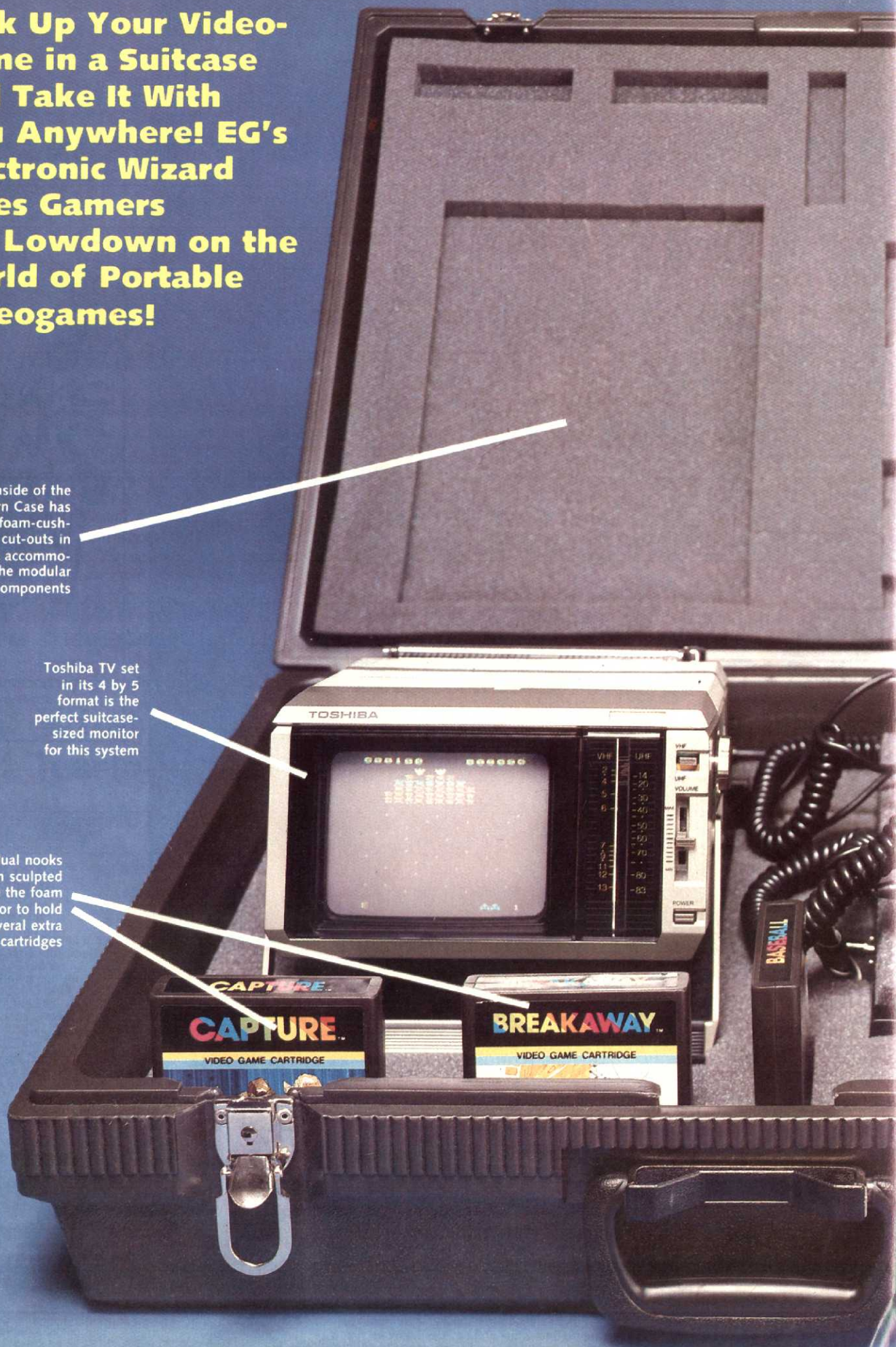



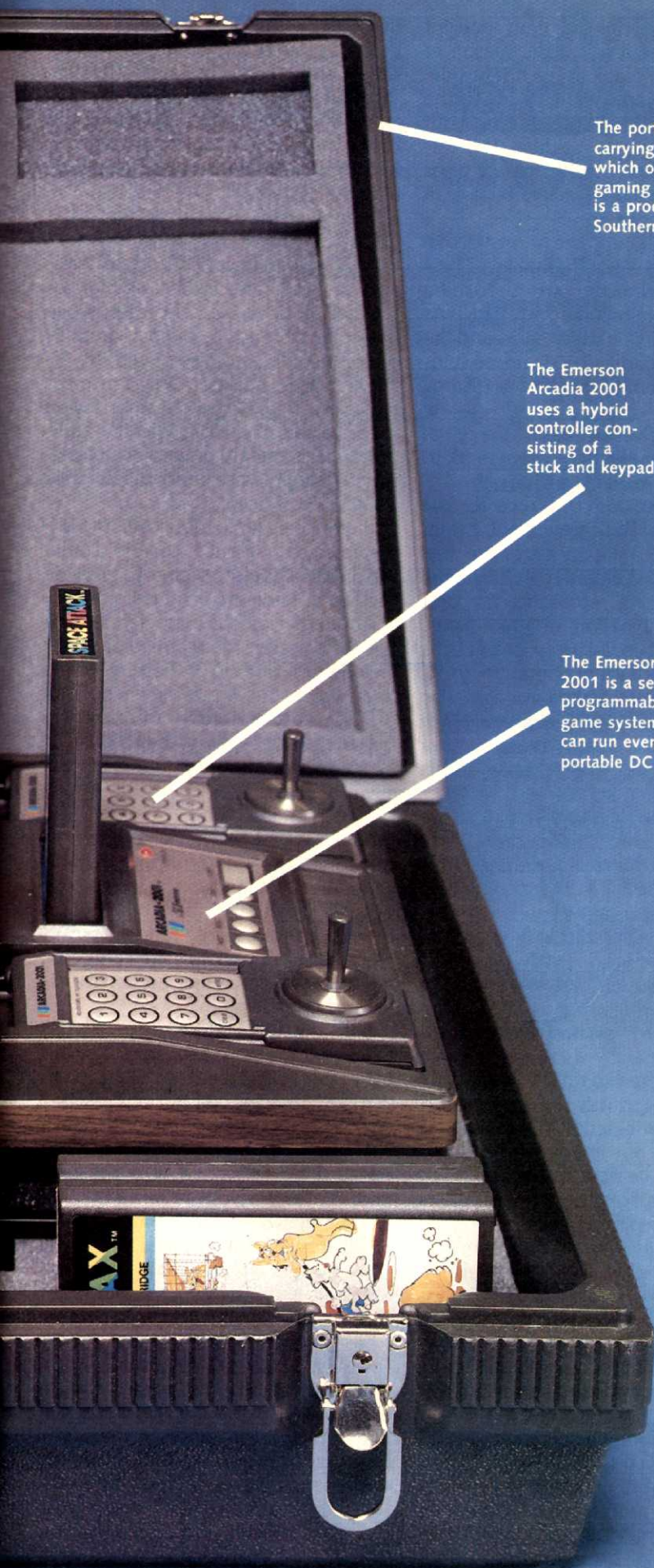

The portable carrying case in which our ultimate gaming gift rests is a product from Southern Case

The Emerson Arcadia 2001 uses a hybrid controller consisting of a stick and keypad

The Emerson Arcadia 2001 is a senior programmable video-game system that can run even on a portable DC source

# The Ultimate Gaming Gift

## It's Here— a System in a Suitcase

By HENRY B. COHEN

**A**s articles in the last couple of issues of **Electronic Games** suggest, there's no shortage of great gift ideas for that arcade ace on your holiday shopping list. And if you really want to knock someone's eyes out, boy, do we have a programmable videogame system for you.

Notice that we didn't say *home* videogame system, and therein lies much of the excitement. Using readily available off-the-shelf products plus one more item that should be in the stores this month—you can create the first totally portable—and that means take it anywhere at all—programmable videogame machine.

Unfortunately, this isn't a system that everyone will be able to afford. The strains of "If I were a rich man" kept running through our heads as we fitted together the pieces of this design puzzle. But if you've got the cash, this is certainly a project worth considering.

This isn't an easy gift to give. In the first place, you can't just run to the nearest electronics store and buy it. You'll have to shop for each component separately and assemble them into the carrying case yourself. And in the second place, as already men-



**NEW** Compare palm size game with other video games

**Nintendo**  
**DONKEY KONG**



**\$39.95**  
Introductory Offer

No Curfews!  
No Quarters Needed!  
Fits in your pocket; Play anytime!  
Sound effects with digital clock alarm.  
6 month guarantee. Other games available.

Please send        DONKEY KONG @ \$39.95 plus \$3.00 handling. Total order \$        (No C.O.D.'s / CA Res. add tax)

Enclosed is Money Order        or Charge to my Master Charge        Visa        Card No.        Exp. Date       

Signature         
Name (Print)         
Address         
City        State        ZIP       

GELECTRONIC PRODUCTS  
P.O. Box 871, Millbrae, Ca. 94030  
Allow 2-3 weeks for delivery.

tioned, this portability stuff doesn't come cheap. But this is the season to be jolly, so let's look at the bright side. Even if you don't want to go to the trouble and expense of crafting your own portable game machine, this system is a marvelous example of what current technology, backed by a dash of ingenuity, can do.

Nestled like the proverbial sugarplums in a Southern Case Company's Travelmaster are a Toshiba 4.5-in. color receiver/monitor, its slightly modified battery pack, and the Emerson Arcadia 2001 home videogame system along with six game cartridges.

EG has chosen each piece of hardware to make the system work to its maximum advantage.

Before selecting this receiver we looked at Panasonic's excellent 2.6-in. and Sony's 3.7-in. models. We feel that in light of cost and screen size, the Toshiba offering represents the best possible combination of ingredients. From the built-in sliding sunshade to its superb overall ease of operation, this is the set of choice. When you consider quality of construction, diminutive size and very light weight (versus other 5-in. color TVs), there really isn't a better choice.

The company name may not be familiar to some, but Southern Case makes about the strongest, most protective, lightweight and fashionable portable equipment containers around. It is available in a choice of sizes and comes with easy-to-configure, pluck-foam interiors. On top of everything else, this housing doesn't scream "expensive equipment contained herein" which might invite the fast-fingered to rip off your prized possessions. But it is the lightweight-sturdiness combination that makes this case hard, if not impossible, to beat. Remember, the case is a critical component of the overall system, as vital as any of the electronic gear.

Interestingly, we didn't have to ponder over which game system to use. Only one stock videogame system operated on 12 volts of DC power, the Arcadia 2001. The unit is also small enough to fit into a case and good enough to warrant such an expensive application. (A brief review of this system may be found in this issue of EG).

The one final touch needed to pull the entire system together currently exists only in prototype so it cannot be illustrated. The gadget in question is the soon to be released 10-in.

Beamscope. This is a magnifying lens that sits a short distance in front of a TV screen and effectively doubles its size. With an estimated size of 8" by 10" by 1/4", it should easily store within the case configuration shown and when it becomes available, will complete the ultimate system.

To power the system, EG used the stock Toshiba battery pack. This unit may be ordered with standard lead-acid or premium nickle-cadmium rechargeable batteries. The latter, while twice as expensive, almost doubles operating life and the speed of recharging is increased. Only the most minor and invisible modifications were made to this pack. This was the addition of a secondary power jack necessary to supply voltage to the Arcadia 2001.

If you decide to duplicate the EG system, a competent TV or audio/radio repairman should be able to provide the tap in under 10 minutes.

Alternative means of powering both the TV and the videogame unit might include utilizing VCR battery packs (but watch out for reversed polarity plugs), automotive or motorcycle batteries, video power belts such as Vidcor's excellent Vidbelt or the cigarette lighter socket in the family car, recreational vehicle or boat. The problem is that any other solution requires additional equipment with commensurate increases in weight and possibly cost. Remember, though, that if you go the route of running power cables to your car, you are foregoing the total self-contained portability aspect of the design.

Similarly, if you already own a small black and white or color portable, this could be substituted for the recommended Toshiba unit.

About the only thing you can't change is the videogame unit itself, because as mentioned, it is the only unit small enough to fit in a case that can be powered by a battery pack without any modifications.

By now you're probably champing at the bit but wondering about the cost of the project, so here's the bad news. At list price the system as described is roughly \$1000.00 including labor, which is admittedly pretty rough. Realistically, with video products selling at their lowest prices in years, you might get by, with careful shopping, with spending only \$800.00-\$850.00.

On the plus side, the TV and its battery pack remain unchanged, so you

*Continued on page 126*

## The MENU

for the Game Gourmet!

### YOUR #1 GAME SOURCE

To: Atari, Intellivision, Parker Bros., Imagic, Apollo, Coleco, Odyssey, Tigervision Spectravision, Activision

And to YOU the

Video Game Gourmet

Seasoned Greetings from VIDEO TAKE-OUT

& The Video Game Update

(fast becoming the most respected newsletter for the serious gamesman)

Our catalog is packed with Goodies & helpful information! We carry EVERYTHING in game software & accessories

Write now & reserve your 1983 edition. It's only \$1.00

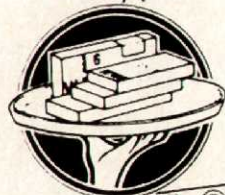

**VIDEO TAKE-OUT**

12115 Magnolia, # 126  
P.O. Box 4702  
No Hollywood, CA 91607  
(213) 761-1561



# WE HAVE SOMETHING EVERY VIDEO GAME PLAYER MUST HAVE, AND IT'S YOURS. FREE.

MINDSCAPE. It's the hottest record in the video game world! It's yours now and it's **free at all leading video game retailers**. You heard right! We brought together a top-notch science fiction writer and one of Hollywood's best sound engineers to collaborate on a listening experience that puts you right inside Data Age's video games.

MINDSCAPE is our way of giving you a taste of five of the most exciting and challenging new



games in town. And MINDSCAPE is **yours free!**

**Listen up. Then move up to Data Age.** Ask for your free copy of MINDSCAPE wherever video game cartridges are sold. Take it home, give it a listen. And then move up to the challenge of DATA AGE™ Video Games.

DATA AGE™ Video Games for the ATARI® Video Game System and Sears' Tele-Games® Video Arcade.™

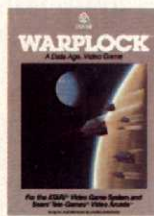

DATA AGE

**UP TO NOW, YOU'VE HAD IT EASY.**





## Scramble: One Against the World

By JOYCE WORLEY

*Riding on the knife-edge of technology is one of the things that makes the electronic gaming hobby so exciting. What was top-of-the-line last year is only passe' this year because of constant breakthroughs in the design of new games. Gadgets are increasingly complex, and concepts that existed only in the minds of last year's hopeful programmers, become this year's proud realities.*

*The three devices in this month's "Stand Alone Scene" are very different from each other, yet each in its own way represents a significant advancement in game design. These are applications of technology that not only were unavailable commercially last year; they were actually impossible.*

### SCRAMBLE

Tomy/\$49

A rocket ship flies above hostile terrain, threatened on every side by enemy missiles, and constantly hampered by low fuel reserves. It takes tricky maneuvering to get past all the barriers, and sharp shooting to battle the fleet of UFOs. Your mission is to overcome all opposition and destroy the enemy space base.

**Scramble** requires the arcader to fly a rocket ship over varied terrain, avoiding obstacles and battling the enemy space fleet. The unit has two

skill levels and elegantly simple game controls. A fire button simultaneously releases bombs and missiles, and an altitude control lever moves the rocket up and down on the screen to avoid collisions.

The gamer maneuvers the ship through four levels before reaching the fifth screen and its enemy space base. The first level is the city. The rocket flies over the barriers, while destroying enemy missiles on the ground or in the air. Flying missiles are worth 20 points to the arcader, and sitting ducks score half that. As the rocket progresses, the fuel level drops. Destroying oil tanks which dot the terrain increases fuel reserves, as well as adding points to the

score. The best strategy in this scenario is to fly high, avoiding all obstructions, while accumulating points and extra fuel.

Next is the meteorite phase. Avoid the barriers on the ground and the pesky chunks of meteorite flying through the air. You can blast oil tanks and stationary missiles for points and extra fuel. The best way to get through this level is to hug the ground as closely as possible, rising into the sky only when necessary to avoid barriers. The meteorites can't be destroyed, but the gamer can amass a lot of points picking off targets, while clearing a path for himself along the surface of the planet.

The third screen features the UFOs. Sinister flying saucers chart a wavering course through the sky. Fuel tanks and enemy missiles line the surface below. Occasional barriers appear, making it impossible for the arcader to get through this screen without actually battling the enemy space fleet. The rocket must fire almost constantly at the shifting UFOs. Bombs, released automatically with each missile, will pick off the ground targets and oil tanks for points and fuel.

If the rocket survives the UFOs, the arcader next guides it through the cave. Barriers fill the screen, leaving only narrow passageways for the rock-

*Continued on page 102*





# INTRODUCING THE SYSTEM CHOSEN 2 TO 1 OVER ATARI® AND INTELLIVISION® FOR REAL ARCADE GAME PLAY!\*

**Exclusive built-in screen for real arcade play - No TV set needed!**  
A revolutionary breakthrough! Only Vectrex delivers fantastic *real* arcade sights, sounds and challenge. Unlike Atari and Intellivision, Vectrex has a *real* arcade screen and sound system built in! No TV set needed! Real arcade controls too: a 360° self-centering joystick and four action buttons put power-packed fun at your fingertips!

**An arcade full of favorites!**  
The fast-paced fun of *Mine Storm*™ is built into the Vectrex console. And for more



*real* arcade variety, plug in Vectrex cartridges like *Berzerk*,<sup>†</sup> *Scramble*,<sup>†</sup> *Rip Off*<sup>†</sup> and *Armor Attack*.<sup>†</sup> Or choose exciting

new Vectrex games like *Clean Sweep*,<sup>™</sup> *HyperChase*,<sup>™</sup> *Cosmic Chasm*<sup>™</sup> and many many more. With still more on the way!

**Convince yourself!**  
Compare the Vectrex Arcade System with any ordinary home video game system. You'll discover why most Atari and Intellivision players say Vectrex plays more like real arcade games than their own systems!

**Vectrex**  
Brings Real Arcade Play Home

## THE VECTREX™ ARCADE SYSTEM!



\*Based on a national survey among players of Atari® CX-2600 VCS, and Mattel Electronics® Intellivision®. © 1982 General Consumer Electronics, Inc. All Rights Reserved. Atari® and VCS® trademarks of Atari, Inc. Mattel Electronics® and Intellivision® are registered trademarks of Mattel, Inc. † Trademark of General Consumer Electronics, Inc. ‡ Trademark of and licensed by Stern Electronics Inc. © 1980 † Trademark of and licensed by Konami Industry © 1981 ‡ Trademark of and licensed by Cinematronics, Incorporated © 1981. Simulator picture of actual game play.



TOMYTRONIC

# SCRAMBLE

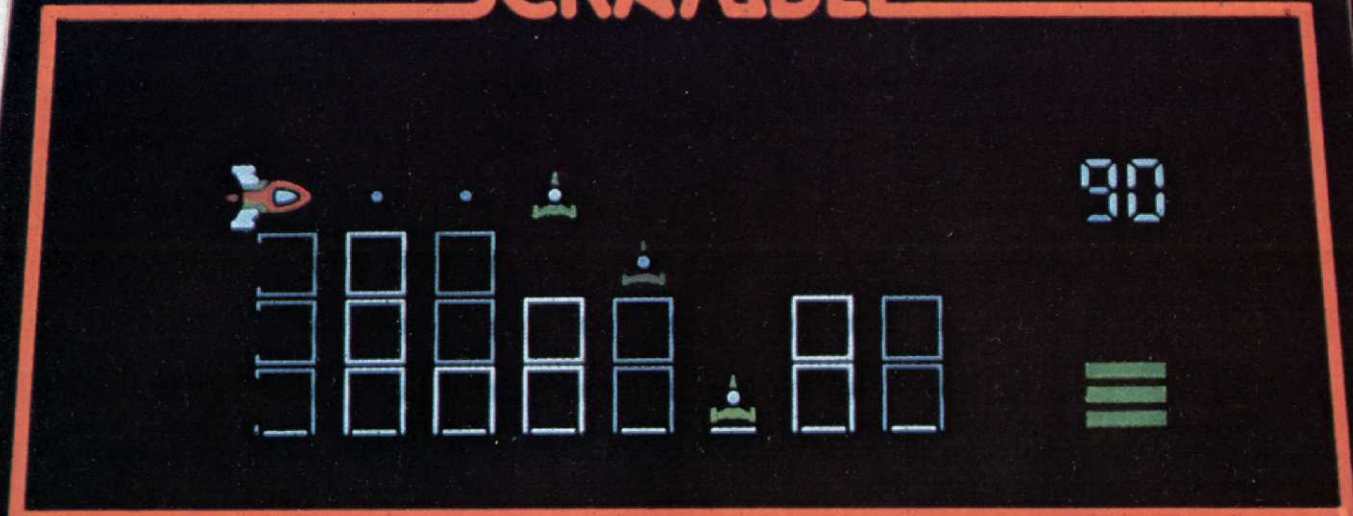

©Konami Industry

TARGETS & POINTS

OILTANK MISSILE UFO MISSILE



30



10



10



20

# OUR FACE STANDS

Let's face it.

With so many games out there, it's tough to make a face that stands out in the crowd.

But we did.

We made our faces big. With brilliant colors. Clear visibility. And game images that are so real, they seem

# PAC MAN







# OUT IN THE CROWD.

to come alive right on the screen. Some of our games even have progressive skill levels, just like real arcade games.

So, don't settle for a plain face, when you can buy one of our electronic games.

And let our face put a smile on yours. **TOMY**®

©1982 Tomy Corp.

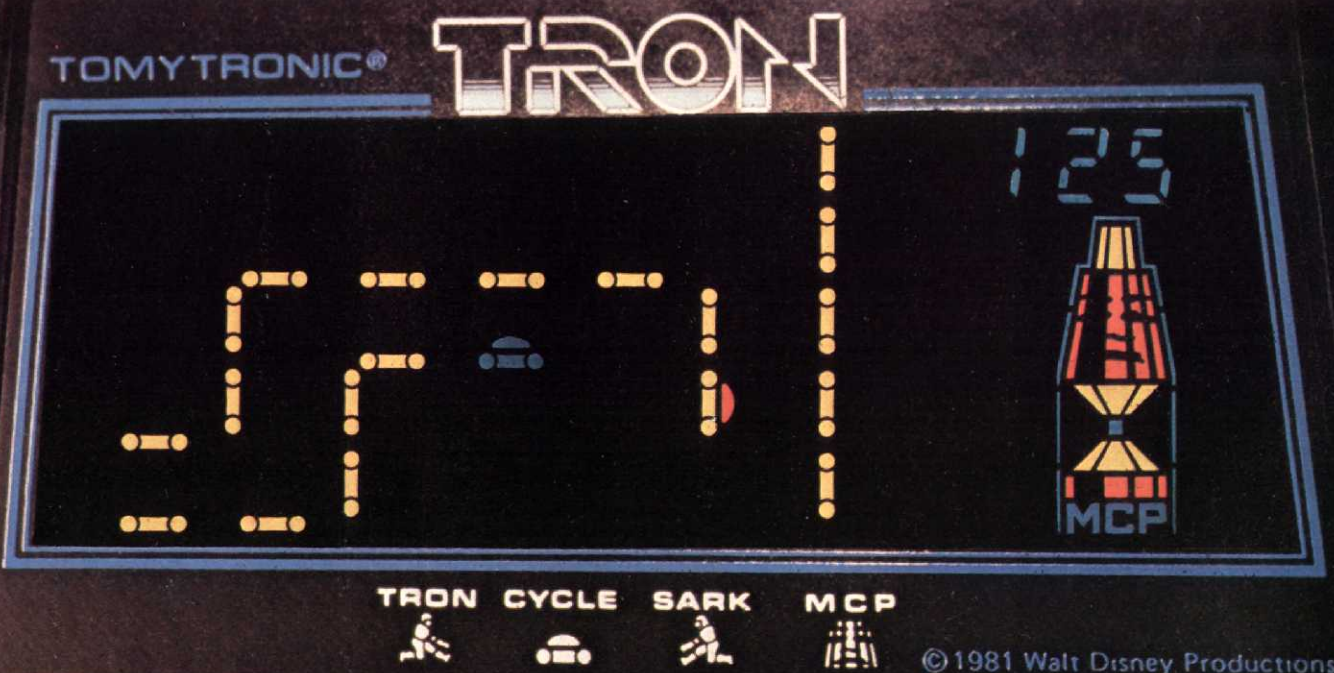



et's flight. Even these small corridors are guarded by missiles and fuel tanks. You must blast them out of the way to make room for the rocket to pass. Steering is the key to mastery of this level. That, coupled with a hot trigger finger, will bring the gamer to the fifth scenario, the enemy space base.

After completion of the fourth phase, the screen goes dark. When it lights again, the rocket faces three vertical columns, each made up of four blocks. Lining the ground are four oil tanks. Beyond the barriers, the arcader sees the space base and his fuel level indicator.

Try to destroy the barriers, but be sure to leave one block in each vertical column. If all blocks in a column are blasted, all columns move forward, and a new intact vertical barrier appears in the row closest to the enemy base. A warning buzzes when fuel reserves get too low. Drop down and pick off an oil tank to restock, then continue blasting the blocks until an opening allows a missile to get through to the base. The trick is to fire just as the last shifting block on the first column starts rising to the top of the sky. Timing the missiles in this way breaks through the columns.

When the enemy space base is destroyed, a bonus score flashes on screen. The base gives 200 points the first time, plus 20 bonus points for each remaining fuel level. Then a fanfare blares and the game restarts at level 1, until four rockets have been destroyed. The space base increases in value each trip through, up to a whopping 600 points on the ninth run of the gauntlet.

Arcaders get an extra rocket at 2000 points on the amateur level, or at 4000 points at the pro skill level.

The digital score counter rolls over at 1990 points. After that, fuel level bars are used to indicate each 2000 points. The highest score possible is 17,990. After that, the counter returns to "0". Rockets are destroyed by crashing into barriers, being hit by enemy missiles, crashing into fuel tanks or the ground, being hit by a meteorite or UFO, or running out of fuel. When the amateur settings in force, fuel decreases one block for every 8 terrain frames passed. At the pro level, the terrain moves faster and fuel is burned up quicker.

At the amateur level, fuel is not the first concern of the arcader. Sufficient oil tanks appear in conveniently blastable positions to keep the rocket going. At this setting, avoidance of the obstacles and destruction of all targets is most important. Steering control is vital. Fortunately the altitude control lever is responsive and easy to use.

*Scramble* is a different game when played at the pro setting. The arcader must be constantly alert to his fuel level, and had better not risk passing even one oil tank.

The graphics are very good. The rocket is blue, green and red, and has fire spurting from its jets. Enemy missiles are green and white, and fuel tanks are red, green and white. The wicked little UFOs look like tiny red

beanies. The space base itself is beautiful; a giant concoction that looks something like a gloriously decorated hot-air balloon. The terrain is composed of blocks which compose the city, all barriers, the maze-cave, and the vertical columns that shield the enemy base.

A year ago it was unthinkable that a stand-alone could produce the changing screens necessary for a game as complex as *Scramble*. This is the first matrixed game with such ambitious graphics. By shifting around the component parts of the matrixed designs, *Scramble* has both sitting and flying missiles, oil tanks, and UFOs, as well as meteorites, the enemy base, and the attractive rocket ship. Further, *Scramble* mixes these parts in random patterns; the barriers, tanks, missiles, UFOs and meteorites are in different positions each time, and no two games are ever exactly the same.

*Scramble* is a remarkable accomplishment in a stand-alone game design. But that's not the important thing about the unit. The fact is—this is a highly enjoyable game, beautiful to look at and challenging to play.

### **Escape From the Devil's Doom & Invaders of the Mummy's Tomb**

Bandai Electronics/\$29

The two newest games from Bandai Electronics use the oldest power source in the world—the sun. While other games make you fiddle with wires and cords, or shell out coins for batteries or adapters, these handheld midgets only







**Astrocade™...the home video game that's a personal computer too!**

3  
Built-in  
Games

Built  
in  
Calculator

3 Octave  
Music  
Synthesizer

256  
Color  
Variations

4  
Player  
Capability

Basic  
Program

# astrocade™

The Professional Arcade™

6460 BUSCH BLVD., SUITE 215 COLUMBUS, OHIO 43229

Manufactured under license from Bally Mfg. Corp.



need a little sunshine to keep them playing. In fact, regular incandescent or fluorescent lights do just as well, so the games are good night or day, rain or shine.

These Bandai bandits are so cute they'll almost steal the money right out of your wallet. Each is housed in a tiny (2½-in. b 3-in.) grey compact-style case that slides easily into a shirt pocket. The lid of the case contains the solar power sensors. These cells absorb enough light to activate the game within

**Escape From The Devil's Doom** starts in hell. The humanoid figure jumps out of a cooking pot and tries to climb a rope stretching up to heaven. Demons and bats bedevil and pursue him as he dashes across the terrain to the rope. When caught, the demons build a fire under him. Three such losses and the game ends. Each time he successfully climbs the rope, 50 points are added to the score. At 500 points, the screen changes to heaven, where he must catch the angel feathers dropped by God. Each is worth 10 points and when the

tally reaches 1000, the little man becomes an angel. He ascends to God and is given a ring, and an additional 500 bonus points.

Unfortunately, that's the end of his heavenly rewards. He is then banished

back to hell where the game starts again. Failure to catch even one feather also pushes him back into the pit; there is very little room for error in heaven. The game continues until the demons roast three little men, or you get to the highest score of 19,999.

**Invaders of The Mummy's Tomb** opens with the adventurer and his camel outside the door of a pyramid. Scorpions and cobras attack the camel. The adventurer must dart back and forth to destroy these desert denizens. Any creature he manages to touch is killed, adding 10 points to the score. When the total reaches 500 points, the explorer can enter the pyramid through its open door. Inside is a large treasure chest of loot. But it isn't all Tutankhamian trinkets, because the pyramid also contains an angry mummy and a vicious spider. Avoid them and scoop up treasure for 10 points. When the hero has a full bag, a buddy appears at the door of the crypt. Pass the bag of treasure to his friend for an additional 500 points. If he can't avoid the attacking mummy or spider, he is pushed back outside the pyramid to battle more scorpions and snakes. The game ends when the camel has been bitten three times, or when the score reaches 19,999.

Play action is a little limited in both games, since all the arcader can do is dance his man around using the left-right movement buttons. The antagonists move very rapidly, and it isn't easy to stay ahead of them. On skill level two, both games move even faster.

These are the first solar-powered games, but they surely won't be the

*Continued on page 128*

a couple of seconds after opening the case.

The game is in the bottom part of the compact. Each has five controls. Choose sound or silent play, and pick between two skill levels. Push the "all-clear" button to ready the screen for a new round. The only controls used during actual play are two buttons to move the gamer-controlled figures left or right.

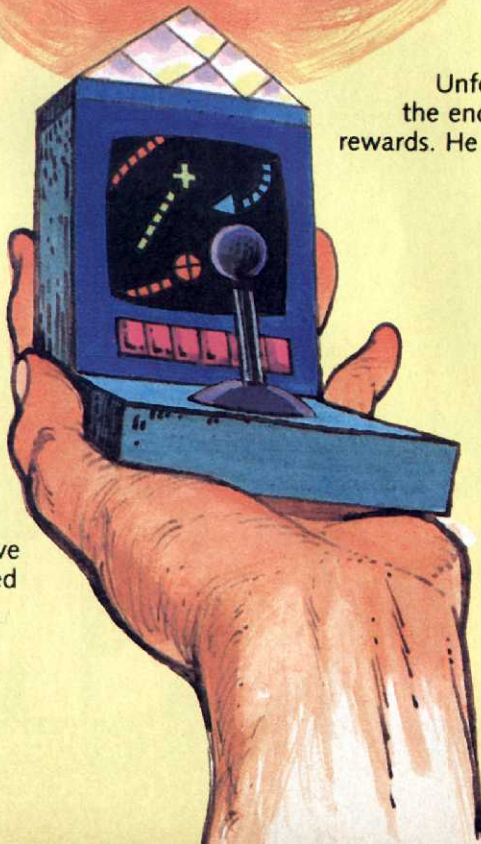
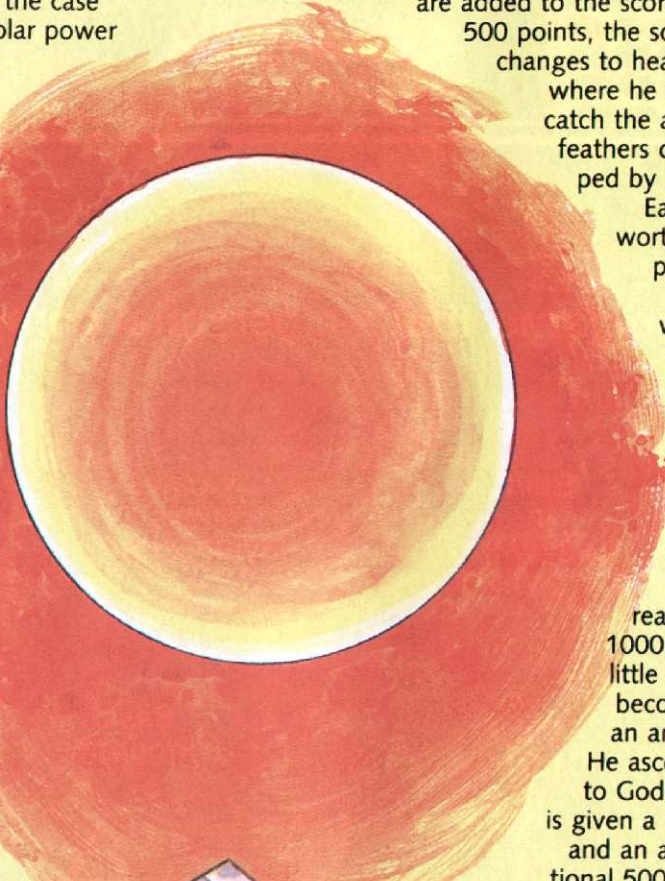

SOLAR-POWERED GAMES





# World's Largest Selection of Commercial and Home Video Games and Accessories.



## Supercharger™ by ARCADIA™ for your Atari® Video Computer System™

Arcadia™ has gone one giant step beyond great video games, by making your Atari® set an even greater video game machine. When you slip the **Supercharger™** into the game slot of your Atari® Video Computer System™, you add advanced electronics and increase the computer memory many times over, giving sharper, more lifelike game characters. The bigger memory can handle more complex games. Your Atari® can now have two totally different, but interrelated, screens for a single game, creating more options, more challenge levels, and more enduring fun.



### Supercharger™ with Phaser Patrol™ Tape:

only \$69.95 + 3.00\* (does not include cassette recorder)



Phaser Patrol™



Communist Mutants  
from Space™



Fireball™



Suicide Mission™

### Additional Cassettes:

**Communist Mutants  
from Space™** .....\$14.95 +2.00\*  
**Fireball™** .....\$14.95 +2.00\*  
**Suicide Mission™** .....\$14.95 +2.00\*



## VECTREX™

Now play all those Vector™ Commercial Video Games in your home exactly as they play in the arcade — without a T.V. set! A great addition to your Atari® Video Computer System™ or Intellivision™ game collection. See graphics not possible on a normal raster scan T.V.! The unit has a built-in 9" Vector monitor and a built-in space game called **Mine Storm™**.

We have Vectrex™ in stock for only \$199.00 + 5.00; with one controller. Extra controller \$34.95 + 2.00! The unit must be ordered with at least four cartridges at \$29.95 each + 2.00! Your choice of:

**Scramble™ Space Wars™ Cosmic Chasm™ Clean Sweep™  
Star Trek™ Rip Off™ Armour Attack™ Blitz Football™  
Solar Quest™ Star Hawk™ Berzerk™ Auto Race™**

### JOIN OUR EXCLUSIVE VIDEO GAME CLUB

Special discounts, contests and a membership card are available to club members.

Send \$2.00 for our latest Catalog & Newsletter telling what's coming in Video Games and club information.

# G.A.M.E.S.™

6626A Valjean Avenue • Van Nuys, CA 91406  
Stores throughout Southern California



## Super Joystick™

The finest made commercial quality for your Atari® Video Computer System™ or Atari® 400/800 Computer™

Sold with 1-year warranty.  
Only \$29.95 each + 2.00\*

California Residents add 6-1/2% sales tax.  
\*Packing, handling and shipping charge.

### WE HAVE EVERYTHING!

Visa and Mastercard holders may order by phone —  
**NO C.O.D. ORDERS.**

For Orders only: 1-800-626-9592  
(Mon.-Sat. 9-5 P.S.T.)

For Information call: 1-213-781-1300  
(Dealer inquiries welcome.)





# COIN-OP CLASSROOM

By BILL HEINEMAN

## Robotron: World-saving Made Easy

The year is 2072. Man has finally perfected the Robotron class android. After serving faithfully for five years, the Robotrons decide that man is inferior and must be eliminated before the humans discover their weakness and destroy the robots. In the

years that followed, man lost many battles and won only a few. The metal men killed most of the world's popula-

tion and forced survivors into slavery. A small rebel group decides that the only way to destroy the Robotrons and save the human race is to create a warrior with superhuman powers and send him to save mankind.

You are that person. Armed with a robot blaster, you set forth to destroy each and every robot that you possibly can and free the humanoids that are held captive. This is the story of *Robotron*.

The *Robotron* game is similar to *Berzerk*, except that the walls are replaced with barriers that you can shoot away, but which are deadly to the touch. Also, in this game, the arcader must fight as many as 200 robots at the same time.

The Gaunt or Sentry Robotrons are so stupid that they make *Berzerk* robots look like super geniuses. The Sentry Robots simply follow you wherever you go. They'll even walk into your line of fire if that's the shortest way to get to you. If you are standing behind a barrier and a Sentry is on the other side, then the Sentry will kill himself on the barrier giving you 100 points for his death (shooting him nets the same score but why waste the ammo?) This type of robot will not shoot at all but will try to kill you with its touch if it gets half the chance. They

also rely heavily on their sheer numbers in their quest for your carcass.





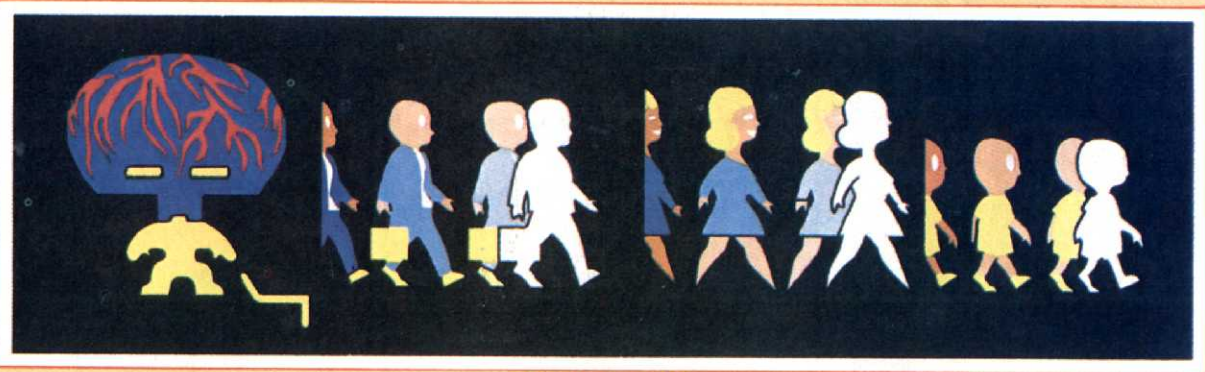

BRAIN AND HUMANS

The Hulk Robotron will attempt to kill any human and destroy all barriers in its way. Shoot it if you like, but nothing will kill this robot so just stay out of its way. Your shots only halt its march for a second, so if your path is blocked by this thing, try to push it out of the way with your blaster.

The Brain Robotrons are the only robots with the ability to turn ordinary people into the deadly Progs by simply taking over the human's mind. The Brains can also shoot deadly Cruise Missiles which are elusive targets. The Brains are worth 500 points, and the Missiles are worth only 25 points. Putting a Prog out of its misery is worth 100 points.

There are also two types of mobile manufacturing plants that build more robots to destroy you. The Sphereoids make Enforcer class Robotrons, which can fire people-seeking projectiles that follow the walls along the playfield's border to seek you. The best way to destroy the Enforcer is to shoot the Sphereoid as soon as possible, so that the Enforcers won't appear. If the little creeps get out of hand, stay away from the walls so that if the people projectiles miss you, they will not turn and kill you from the side. Killing an Enforcer is worth 150 points, a Sphereoid counts 1000 points, and People Seeking Missiles are worth 25 points.

The Quarks are the other robot-makers that are determined to give you a hard time. The Quarks stamp out

new Tank Robotrons so fast that it will make your head spin. The bad thing about the Tanks is the Bounce Bombs they fire. Bounce Bombs get their name because they will bounce off the play screen border and hit you from behind. Shooting down the bombs is vital to survival. If you keep shooting down the bombs, the tanks eventually run out of ammo and are then at your mercy. Keep in mind that they can still

by mistake, the bullet passes through the person and hits whatever is behind it. The first human gives you 1000 points for its rescue, the second is worth 2000 and so on until the point value reaches 5000. The point value will stay at 5000 for all remaining humanoids in the same round. When any round is completed, or you have been slaughtered, the value of a saved human is reset to 1000.

Now that you know the rules of the game, how about some strategy? The first round is very simple: charge, attack, shoot and kill. Destroy all robots except one. Then pick up the humans and waste the last robot. The second round has the Hulks and a Sphereoid as well as some Sentries on your tail. For the first few seconds, kill some Sentry robots and collect a few humans while watching where the Sphereoid is headed. Once you know the general direction, follow the Sphereoid and shoot it at the earliest opportunity. By now, the Sentry robots have formed a line and are coming straight at you. Just aim your gun and turn them into expensive junk. It's not hard.

Repeat this process for every time there are barriers and up to 50 Sentries in the round. Remember this hint: The Sentries are destroyed if they hit a barrier, so don't shoot barriers if there are Sentries on the other side: concentrate on Sentries that have a clear path to you. Brain attacks are the most difficult ones to survive, if a large number of Cruise Missiles are stalking the on-screen hero.

The way to live through a Cruise Missile attack is to shoot in the general direction of the missiles. Also, shoot as many brains as possible so that they can't fire more Cruise Missiles. If some poor sod has gotten turned into a Prog, put him out of his misery, but try hard to rescue the humans so you can re-



TANK SCENARIO



BRAIN SCENARIO

run you over with their tractor wheels. The Tanks are worth 200 points each and Bounce Bombs are worth 25.

The best way to rack up the points is to save the humanoids. (Did you forget already that this is why you're fighting these weirdos in the first place?) To save a humanoid, all you do is touch the person. A good thing about the blaster is that if you shoot a humanoid



# EXCHANGE YOUR USED VIDEO GAMES FOR ONLY \$3.50 per game

WHEN YOU JOIN OUR  
VIDEO EXCHANGE CLUB  
LIFETIME MEMBERSHIP  
ONLY \$18.00

JOIN NOW and RECEIVE  
our membership package  
plus many

SPECIAL DISCOUNTS,  
FREE OFFERS and  
LOW LOW PRICES  
on all brands of video games

Mail \$18.00 for your membership or just  
send \$1.00 for further details, SPECIAL  
DISCOUNT CATALOG and NEWSLETTER  
(check or money order please)

CANADIANS: Money orders in U.S. funds only  
and exchanges \$4.50 instead of \$3.50

VIDEO FUN & GAMES inc.  
Box 1010 - 1204 Ave. U - DEPT TS  
Brooklyn, N.Y. 11229

## ATARI 400 HOME COMPUTER



\$249

16K

32K...\$389, 48K...\$489  
ATARI 410 Cassette \$76  
ATARI 810 Disk Drive \$449

ATARI 800  
HOME COMPUTER  
16K...\$649, 32K...\$729, 48K...\$769

COMPLETE SELECTION OF SOFTWARE

computer  
mail order  
east 800-233-8950

In Pa. Call (717) 327-9575  
477 E. Third St., Williamsport, PA 17701

west 800-648-3311  
In Nev. Call (702) 588-5654  
P.O. Box 6689, Stateline, NV 89449

ceive the megapoints instead of 100 points for a Prog.

In the Quark attack, simply shoot in all directions and try to target all the Quarks before they can release the Tanks. If you see a Tank growing up out of the ground, then you better waste him before he gets a chance to



ROBOTRON COIN-OP

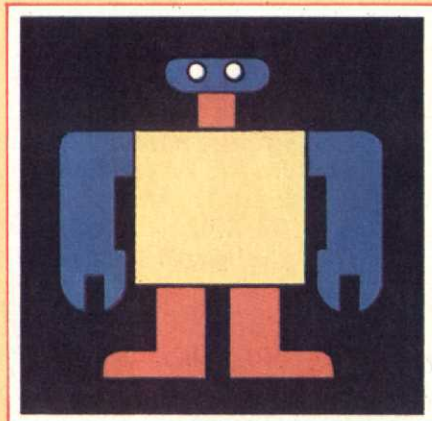

HULK

# PRO-VIDEO<sup>TM</sup>\*

## CONTROL GRIP

\*pat. pend.



For Your Atari VCS,  
Sears Video Arcade,  
VIC-20 Or Colecovision  
To Get A Better Grip On  
Your Game.

- Conforms To Your Hand
- Squeeze Action Firing
- Virtually Indestructible
- 1 Year Replacement Warranty
- FREE 15 Day Trial Period

Cut Out Coupon And Mail

Please send me \_\_\_\_\_ PRO-VIDEO control grip(s) @ \$29.95 ea., for my \_\_\_\_\_ Atari,  
\_\_\_\_\_ Sears Video Arcade, \_\_\_\_\_ VIC-20, \_\_\_\_\_ Colecovision. I enclose \_\_\_\_\_\*\*  
plus \$2.00 for postage & handling for each unit.

Name \_\_\_\_\_

Street \_\_\_\_\_

City \_\_\_\_\_ State \_\_\_\_\_ Zip \_\_\_\_\_

MasterCard # \_\_\_\_\_ Visa # \_\_\_\_\_ Exp. Date \_\_\_\_\_

\*\*CT residents to include 7 1/2% state sales tax • No C.O.D.'s • Dealer inquiries welcome.

SYNTISA RESEARCH

MASON ROAD, P.O. BOX 186-B • BROOKLYN, CT 06234

SYNTISA RESEARCH

IS NOT AFFILIATED IN ANY WAY WITH THE ABOVE MENTIONED PRODUCTS OR MANUFACTURERS.

throw a few Bounce Bombs at you. If the Tanks become too numerous, retreat to the middle of the right or left wall and fire into the center of the field until the Tanks are destroyed.

Sooner or later, you are going to get the Robots very angry. That's when they'll call in so many Sentries you



# HO HO HO HO HO HO



## INTELLIVOICE™



Space Spartans  
Bomb Squad • B-17 Bomber  
TRON Solar Sailer



Astroblast • Space Attack  
Lock 'N Chase • Frogs & Flies  
Super Challenge Football  
Super Challenge Baseball

## INTELLIVISION®

What's New?

Utopia • Frog Bog  
Lock 'N Chase  
New Dungeons & Dragons  
TRON Maze-A-Tron



"Games of the Century"  
Beany Bopper  
Worm War I • Fast Eddie  
Deadly Duck • Turmoil  
Megaforce • Alien



We carry a full line  
of ATARI video game  
cartridges.

## ACTIVISION

BEATS THE REAL THING.

Star Master  
Chopper Command  
Pitfall  
Megamania  
Pitfall • Stampede

## IMAGIC

Demon Attack  
Micro Surgeon  
Beauty and the Beast  
Swords & Serpents  
Atlantis • Demon Attack



Infiltrate  
Kyphus • Guardian  
Final Approach  
Wabbit • Pompeii

## COLECO

Donkey Kong  
Venture  
Mouse Trap  
Donkey Kong

## PARKER BROTHERS

Frogger  
Star Wars  
The Empire Strikes Back  
Amidar

## vidtec

Squeeze Box  
Word Zapper  
Commando Raid  
Towering Inferno

## SPECTRAVISION™

Planet Patrol  
Gangster Alley  
Cross Force  
Tape Worm  
China Syndrome  
Nexar

Accessories:  
Quickshot  
Joy Stick



ATARI CX-2600



INTELLIVISION

**UNITED VIDEO OF AMERICA**  
P.O. Box 7333, Newport Beach, CA. 92660  
Phone orders only:  
**1-(800)245-1111**

In Calif: 1-(714) 955-2252

†Visa, Mastercard, Cashiers Check or Money Order Only.



## Get a Grip on Your Atari® Joystick with **THE BALL™**

Just Like Those Seen on Arcade Games

- More Control
- Higher Scoring
- Less Fatigue
- Slips on/off

**\$395/Pair** + \$1.50 Postage & handling

**ORDER NOW!**

Send check or money order to:  
**DARBE PRODUCTS**  
P.O. BOX 154 LYONS, IL 60534

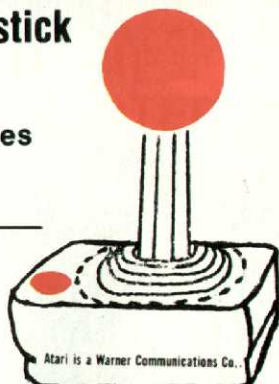

Dealer Inquiries Invited!

won't be able to count them all. This special round can be recognized by the fact that there are no barriers to stop the Sentries and the sheer number of those little red robots. The way to escape is to shoot straight down and clear a path through the robots so you can run toward the lower wall. Upon reaching the wall, fire the gun to the right and walk along the wall to the corner as fast as you can while shooting in an upward diagonal pattern.

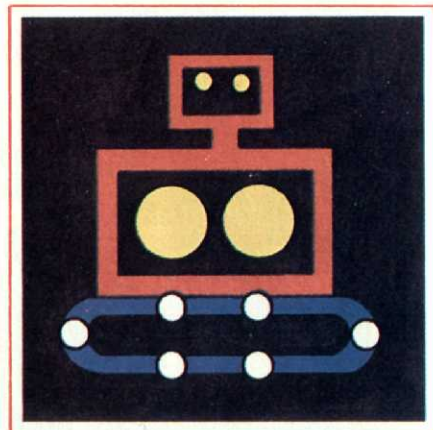

TANK

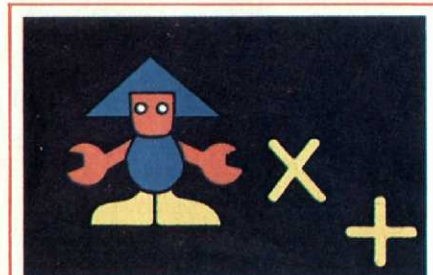

SPHEROID

GRUNT

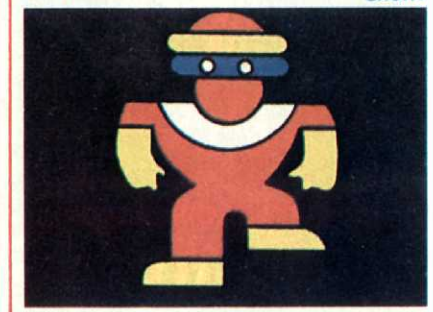

When you reach the corner, run straight up while firing into the crowd of robots. By this time the Spheroids will have made their Enforcer robots and dispatched them toward you. You're really going to have your hands full in this spot, so shoot a burst of bullets at the Enforcers, a volley at the Sentries, and then again at the Enforcers until all robots are dead.

That's all there is, other than quick thinking and reflexes. Use these hints and you should improve your scores drastically. And remember: save the humanoids!

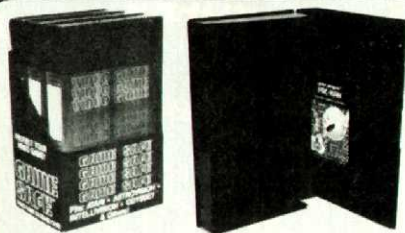

## GAME SAFE™

The Safest Place  
For Your Video Games!

Attractive protection for your expensive video game collection.

Interior sleeve holds instructions and overlays — prevents loss and damage!

UNIVERSAL! Fits

- ATARI™ • ASTROCADE™
- ODYSSEY™ • INTELLIVISION™ and others!

TOTAL VIDEO SUPPLY

TVS

The Leader In Consumer Video Accessories

9181 Kearny Villa Court • San Diego, California 92123 • (714) 560-5616

**ARE YOU UP  
TO THE  
CHALLENGE?**

Top game scores—Gorf!™ 32700; Wizard of Wor!™ 99500. CBS Video Games.

© 1982 CBS, Inc. Hagerstown, MD 21740. "Gorf" and "Wizard of Wor" are registered trademarks of Bally/Midway Mfg. Co.



# Hook up to awesome...

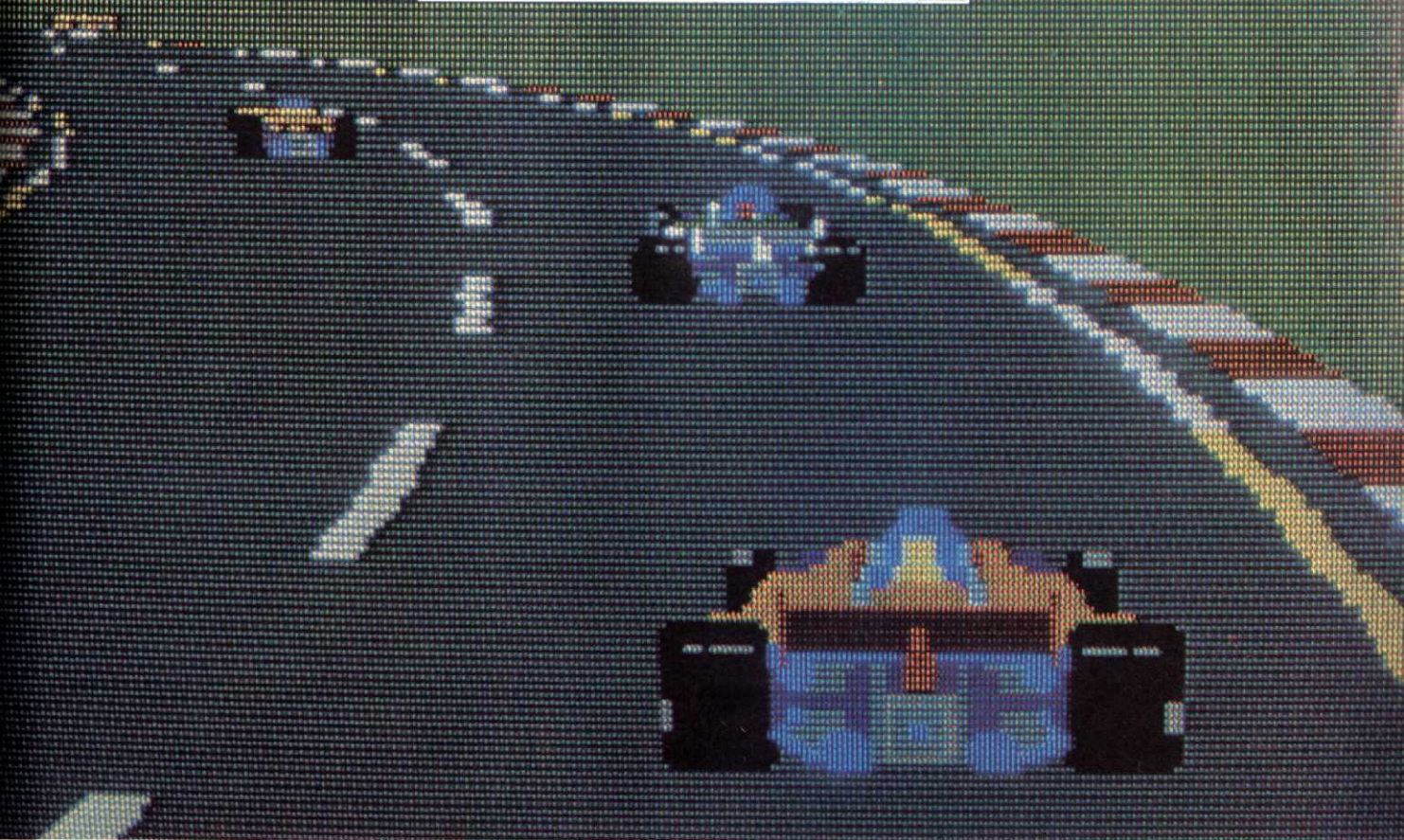

Awesome speed, awesome thrills. New Pole Position™\* from Atari® puts you in the action. In the cockpit of a screaming Formula 1 racing machine...

You've finished your qualifying lap. Fast enough to earn the Pole Position! A thousand horses strain in anticipation.

Your heart pounds. Starting lights blink the countdown. You touch the throttle. The response takes your breath away as your car lunges off the grid and propels you into the fastest most challenging Grand Prix ride of your life.

Signs, landscape, other cars blur as

you master the challenge of the track in this incredible new coin video racing experience from Atari. It's driving excitement to the max. Can you handle it? Play it. Ask for it where you play coin video games. Today.



**Atari Pole Position. Hook up to hot.**



# MINI ARCADE GALLERY



## New Mindbusters for Microvision

By JOYCE WORLEY

Milton Bradley is continuing to support Microvision, the smallest programmable unit currently on the market, with new game cartridges. The master component is modestly priced (around \$40), fits nicely in one hand, and features a black and white liquid crystal display. Movement is controlled by keypad or paddle.

Microvision makes up for what it lacks in flashy graphics with the versatility of the library of games available for the unit. When the arcader tires of **Block Buster**, the wall-bashing game packed with every Microvision, he can choose among the largest selection of cartridges currently available for any of the mini-arcade units.

the ring squares. Once again, the computer tells how many moves are required to solve a puzzle it devises, but you can design the game yourself. In either case, the game starts with three rings on screen. Pressing different buttons eliminates rings in some squares while adding them to others.

The computer keeps track of as many as 32 moves. However, you can continue seeking a solution even after the tally stops, for as long as it takes to solve either of these ingenious stumpers.

### MINDBUSTER

M.B. Electronics/\$17

Remember the paper and pencil puzzles you used to work in study hall? **Mindbuster** contains two of these, electronically updated for the Microvision unit. Both will keep the puzzle fan busy for hours.

Choose either **Rings** or **Lights Out**. The computer devises the puzzle, or the gamer may design it himself by placing the game elements around the board where he chooses. If the computer is the challenger, it indicates the fewest possible moves in which the puzzle can be solved.

**Rings** is an electronic version of the ring-toss game. Single black blocks must be surrounded by ring squares. The puzzle is solved when all black blocks are properly corralled, with no surplus ring squares left over. Do it in the number of moves indicated by the computer and you win the game! It's

trickier than it looks since each button triggers a set pattern of ring movement around the screen, eliminating some and placing others in new locations. It takes strategy and careful planning to find the perfect solution.

**Lights Out** turns the ring game inside out. Now the arcader eliminates all

### SEA DUEL

M.B. Electronics/\$17

**Sea Duel** pits a destroyer against a submarine in a stirring naval battle,

Two new contests from Microvision

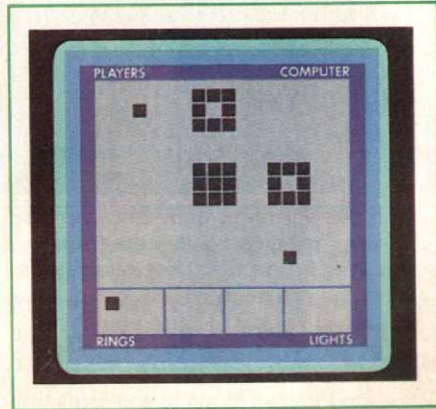
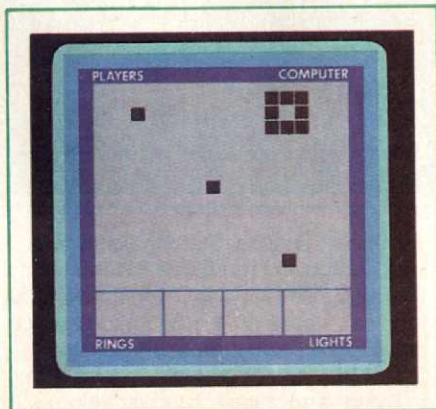



# No More Wires.

Introducing **GAME-MATE 2™**

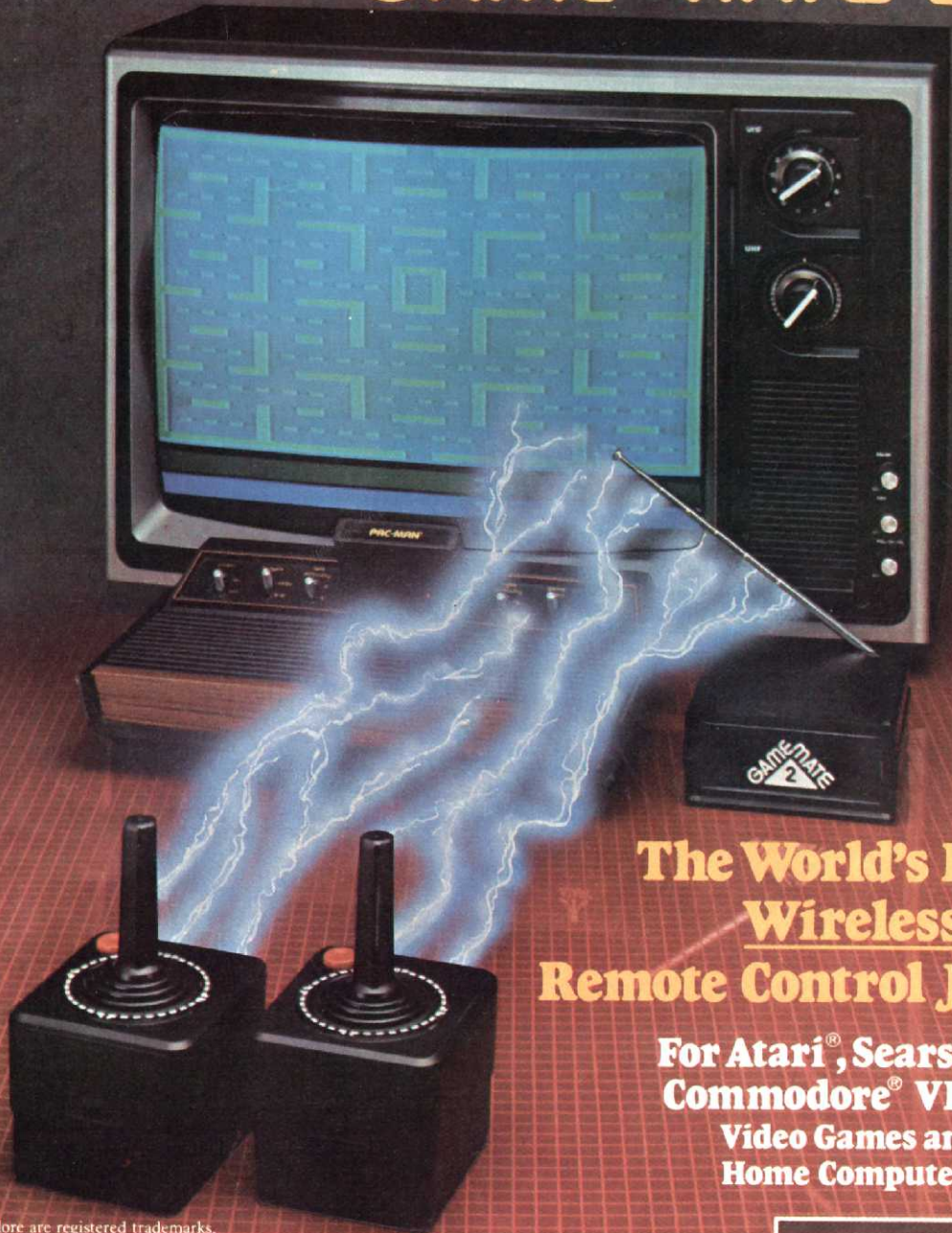

**The World's First  
Wireless  
Remote Control Joysticks**

**For Atari®, Sears® and  
Commodore® VIC-20  
Video Games and  
Home Computers**

Atari, Sears and Commodore are registered trademarks.

**Sit back...way back...and enjoy...**

The new Game Mate 2™ lets you enjoy the fun, the exciting action, the challenge of your Atari® Video Computer System, Sears® Tele-Game or Commodore® VIC-20 video games or home computers from up to 20 feet away without fussing and fiddling with ugly feet-entangling wires.

The Game Mate 2™ is sturdy built, easy to hook up, and won't interfere with your normal TV viewing.

You'll enjoy the same sharp colors and realistic sound effects, but with the 'long distance' fun of a lifetime!

Look for the Game Mate 2™ and other Game Mate™ accessories wherever video games are sold.

**GAME-MATE™**  
VIDEO  
ACCESSORIES



**CYNEX**

**CYNEX MANUFACTURING CORP.** 28 Sager Place, Hillside, New Jersey 07205 (201) 399-3334



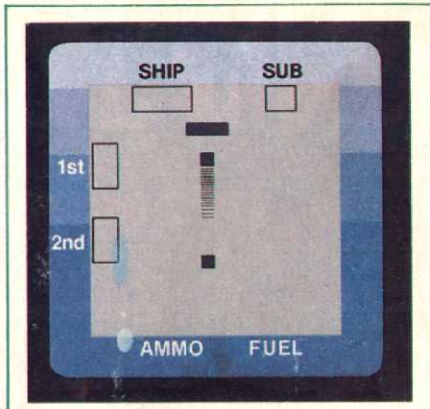
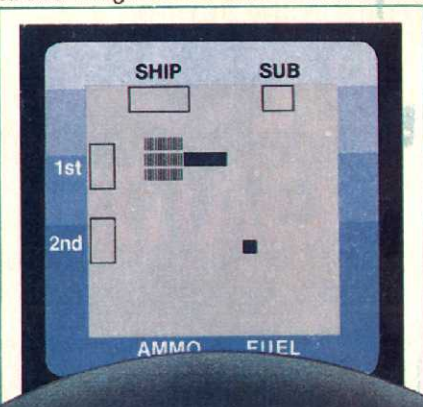
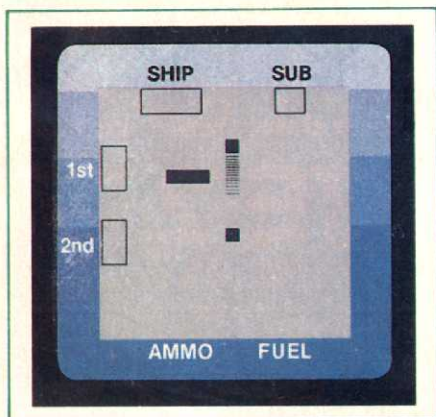

that should please strategy fans. Choose to man either the battleship or the submarine, and let the computer take the other side, or play head-to-head with another enthusiast. This contest of wit and strategic planning is one of the most successful games ever programmed for Microvision. *Sea Duel* may owe a tip of the hat to the pencil-and-paper version of **Battleship**; the object is the same in both games, to hit and sink the enemy by firing salvos where you hope the other ship may be. But electronic circuitry has updated this antique pastime to make it a real contest.

The LCD displays a ship (three square blocks) and a submarine (one square block). The player uses the 4-direction movement and firing buttons to move his vessel two spaces and fire two rounds in each of the two movement and firing segments that make up every skirmish. Press the go button to enter the battle plan into the computer when the first segment is completed; then complete the second segment of programming by en-

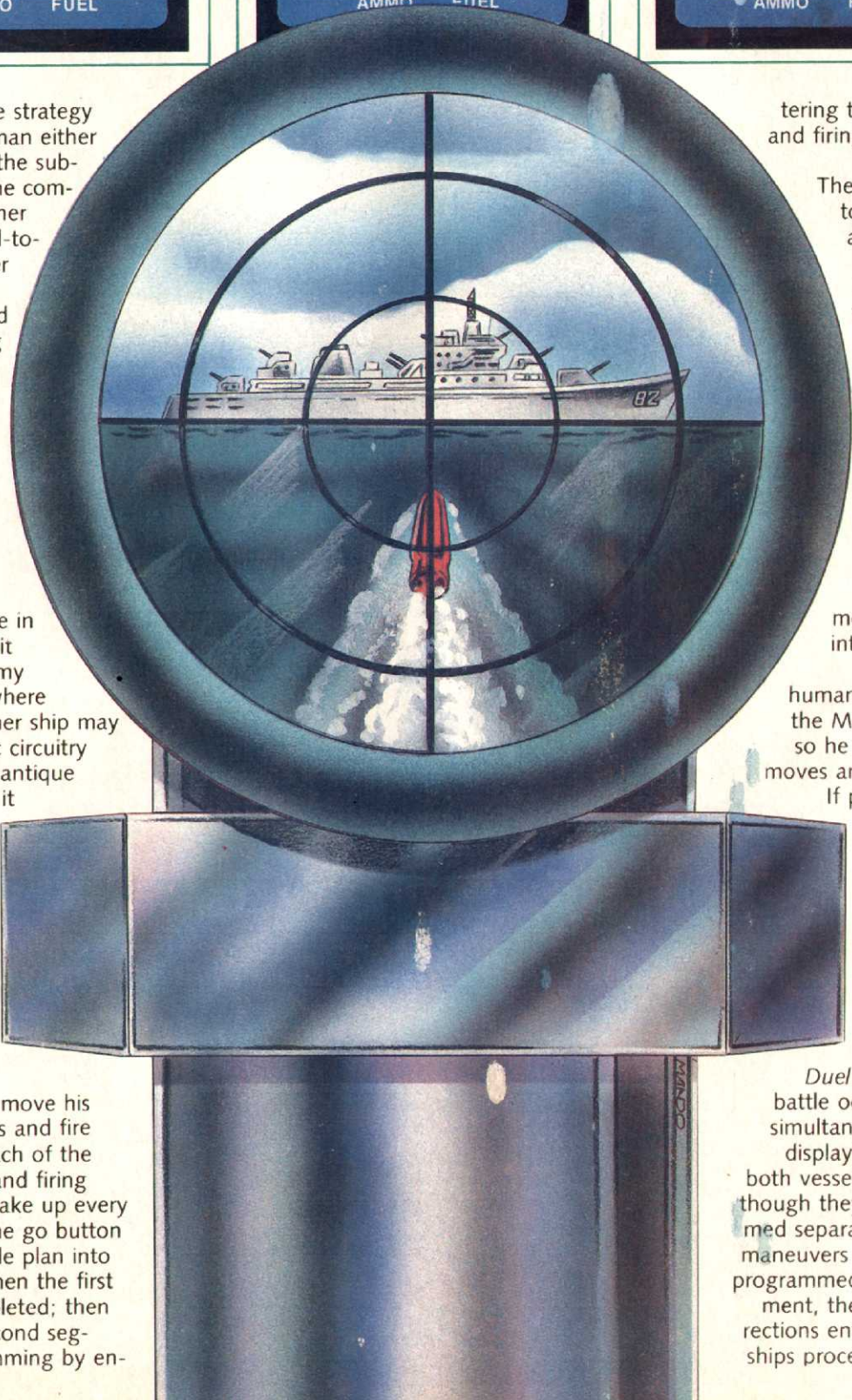

tering two more moves and firing two additional salvos.

The vessel responds to the commands as the player enters the movements, in a preview of how the action will go in the real battle. If he has other ideas, he can then press the clear button and reprogram that segment. Once he presses the go button, all moves are entered into the computer.

When playing a human opponent, pass the Microvision to him so he can program his moves and firing pattern.

If playing the computer, the opposing vessel's movements are automatically programmed.

After all moves are entered, press the go button to see *Sea*

*Duel* do its stuff. The battle occurs by multiple simultaneous movement, displaying the action of both vessels together, even though they were programmed separately. Each vessel maneuvers into the position programmed in the first segment, then fires in the directions entered. Then both ships proceed with the sec-



▪ **SPECIAL HOLIDAY OFFER** ▪

# Any Game at Our Cost

with Membership in the **GAME-OF-THE-MONTH-CLUB**.

(Limit 4 games per club member)



JH221 ~~+\$2.50~~ **\$5.95**



GAMES Magazine "Top 100"

PE902

~~+\$2.00~~ **\$5.95**

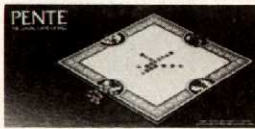

GAMES Magazine "Top 100"

PB562

~~+\$4.00~~ **\$6.95**

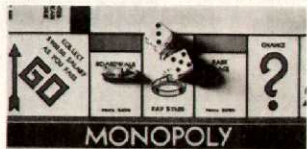

GAMES Magazine "Top 100"

~~\$5.00~~ **\$2.50**  
KR302



KR123 ~~+\$10.00~~ **\$4.95**



DD315 ~~+\$10.00~~ **\$4.95**



GAMES Magazine "Top 100"

JH403

~~+\$12.00~~ **\$5.95**



GAMES Magazine "Top 100"

IG402 ~~\$6.00~~ **\$3.50**



GAMES Magazine "Top 100"

RT555

~~+\$16.00~~ **\$7.95**



~~\$7.00~~ **\$3.50**



TR104

~~+\$15.00~~ **\$6.95**



the local investment game

PR333 ~~+\$10.00~~ **\$5.25**



AH237 ~~+\$15.00~~ **\$7.50**



GAMES Magazine "Top 100"

SR813

~~+\$12.00~~ **\$5.95**



GAMES Magazine "Top 100"

TR201

~~+\$13.00~~ **\$4.95**



## Video Games --- for Atari

PB7560 ~~\$34.95~~ **\$23.95**



AC6060 ~~\$31.95~~ **\$17.95**



CO4210 ~~\$27.95~~ **\$23.95**

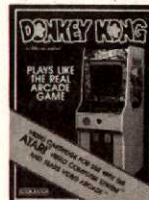

AC6070 ~~\$27.95~~ **\$12.95**



AT3210 ~~\$34.95~~ **\$21.95**



## TO: Club Members: AT LAST!

A Game-of-the-Month-Club

- News on local, regional & national game tournaments
- A forum for exchange of ideas on gaming
- Exposure for the individual game inventor and new manufacturers
- The **BEST GAMES** at the **BEST PRICES**

Take advantage of this fantastic introductory offer and **SAVE** up to **50%** and even more on your holiday game shopping. Our buying power allows us to offer you these games at our cost with continued savings throughout the year. **ORDER NOW** and beat the holiday rush.

## • HERE'S HOW THE GAME-OF-THE-MONTH-CLUB WORKS:

After your membership's accepted you can take advantage of this special holiday offer by choosing as many as 4 games priced at our cost, plus shipping and handling. With membership you will receive **FREE** the new hit game **DOTTO**. You need to purchase only an additional 4 games at our low discount prices during the next two years.

• **DISCOUNT PRICES:** We guarantee that our games are from the actual manufacturers and that our club prices will be at least 10% - 50% lower than the manufacturers suggested retail price. All Club members are entitled to manufacturer rebates.

• **VARIETY:** The **GAME-OF-THE-MONTH-CLUB** features a wide variety of games including **FAMILY GAMES**, **STRATEGY GAMES** and **VIDEO GAMES**. We want to offer you some of the lesser known great games as well as some of the classics. Many selections will be from the **GAMES Magazine "Top 100"**.

• **NEWSLETTER:** About once a month (4 to 6 weeks), you will receive a newsletter featuring our selection for the **GAME-OF-THE-MONTH-CLUB**. If you want this selection, do nothing, we will send and bill it to you automatically. If you want one of our 50 alternate selections or no game at all, simply indicate this on the reply card and mail it within 10 days. You will never receive a game you do not want.

• **SATISFACTION GUARANTEED:** If you are not completely satisfied with the games you order from this ad, return your selections within 10 days. We will cancel your membership and you will owe nothing. The **FREE** game **DOTTO** will be yours to keep.

• **CANCELLATIONS:** You may cancel membership any time after you purchase your 4 additional games. If you continue your membership you will be entitled to an **EXTRA 5% DISCOUNT** on future purchases.

## Game-of-the-Month-Club

P.O. Box 28484 San Jose, CA 95159

Please accept my application for membership in the Game-of-the-Month-Club and send me the selections I have numbered below. I can choose up to 4 games and will be billed at your cost plus shipping and handling charges. I understand that I will buy just 4 more games during the next two years. I agree to the Club Plan as described in this ad and will be able to keep my **FREE** game, **DOTTO**, even if I do not remain a member.

My selections: #1  #2

#3  #4

#5 **DOTTO - FREE**

Mr. \_\_\_\_\_

Ms. \_\_\_\_\_

(Please Print)

Address \_\_\_\_\_ Apt. \_\_\_\_\_

City & \_\_\_\_\_

State \_\_\_\_\_ Zip \_\_\_\_\_

If under 18, parent must sign: \_\_\_\_\_

Please charge my:

VISA # \_\_\_\_\_

MASTERCARD Exp. Date \_\_\_\_\_

Members accepted only in U.S.A. Offer varies slightly for foreign countries. Offer good until Dec. 31, 1982.



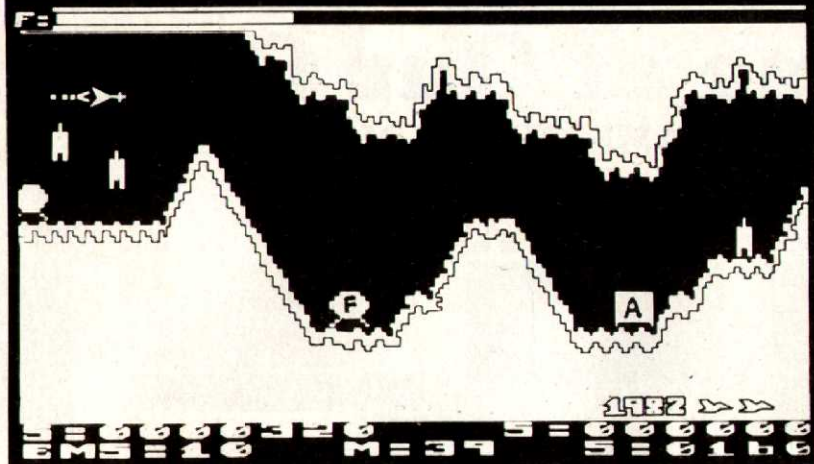

# AIRSTRIKE

**NEW! AIRSTRIKE FOR THE ATARI 400/800 16K**

- INTRODUCING THE NEW ARCADE-STYLE GAME FOR ATARI COMPUTERS!
- SUPERB FINE SCROLLING GRAPHICS AND DAZZLING ARRAY OF COLOUR.
- FIGHT YOUR WAY THROUGH CAVERNS AND TUNNELS WITH ATTACKING MISSILES. FUEL AND AMMO DUMPS TO CONTEND WITH!
- 100% MACHINE CODE PROGRAM FOR ONE OR TWO PLAYERS.
- MULTIPLE SKILL LEVELS.

AVAILABLE NOW ON 16 K CASSETTE: \$39.95  
 AT YOUR LOCAL DEALER-ASK FOR A DEMONSTRATION  
 ATARI IS A T.M. OF ATARI INC.



## ENGLISH SOFTWARE COMPANY

P.O. BOX 3185 REDONDO BEACH, CALIFORNIA 90277

ond movement segment and fight the skirmish that was programmed.

The score flashes on screen after the battle. Check to see how much ammunition and fuel is left, then program the next encounter. The game ends when one vessel scores six or more hits against the other, or runs out of fuel.

Sea Duel is every engaging. Since it doesn't depend on clever graphics for its appeal, it is perfectly suited for Microvision.

## PINBALL

M.B. Electronics/\$17

Designing a pinball game for a screen that measures just 1¼-in. on a side must be a test of programming skill.

The gamer chooses to play 9, 7, 5, 3 or 1 ball, at fast or slow speed. The surprise in the game is that he also chooses the size of the paddle, because the ball in this game is batted around the screen by the arcader, rather than shooting from entry slots and bouncing from spinners.

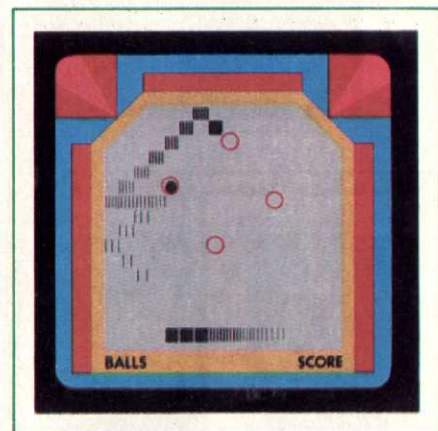

Flipper games go pint-sized with M.B.'s pinball

The only ornamentation on the screen is four red circles in a diamond pattern in the center of the field. Serve the ball from your paddle, then use the control knob to keep the ball bouncing off the sides of the walls and the red bumper circles. Score 1 point every time the ball hits a bumper. Hit the same bumper four times and it lights.

This is a rather minimal pinball game. It lacks graphics altogether and could have benefited from a prettier overlay to provide some of the attractive elements arcaders love in pinball machines. However, it's a good ball and paddle game. The arcader has to be deft-fingered to keep up with it when the ball starts ricocheting between the bumpers, walls and ceiling at top speed.

## FingerTip Controller for the Atari®



\$19.95

Works with all games that use a joystick

Direct from the manufacturer

**KY ENTERPRISES**

195 Claremont, #288, Long Beach, CA 90803

(213) 433-5244

Available in kit form—\$14.95.

Shipping charge \$3. Calif. residents add 6½% tax.

- 5 responsive arcade-quality durable buttons for 4 directions & "fire"
- Faster direction changes
- Rapid firing—improved scores
- 2 year warantee
- 30-day moneyback guarantee
- Left-hand models available
- Fits on top of video game console

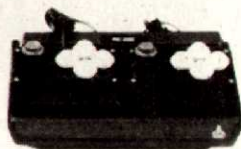

Controllers for handicapped also available. Write for information.

Atari® is a registered trademark of Atari Inc.

## ADD "FIRE POWER FP-1" to your \*VCS Joystick Controller

- Provides continuous rapid fire when the fire button is depressed
- Easy to install (no soldering)
- Improves scores, reduces fatigue
- Price \$9.95 + \$1.50 postage and handling (No COD's, VISA and MC accepted)

Phone Orders: Call 1-513-832-1322

Mail Order To: Gammation  
 P. O. Box 1028  
 Fairborn, OH 45324

Send \$1.00 for our brochure of Gammation

\*VCS Game Cartridges and Accessories Dealer Inquiries Accepted.

\*VCS is a Trademark of Atari  
 Ohio residents add 6% sales tax

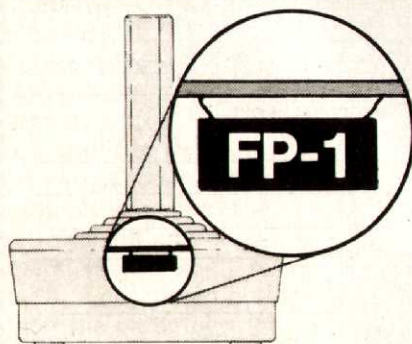

**Gammation**



# GROW WITH US!

A special message for electronic games retailers



Playing electronic games is now America's fastest-growing hobby. Here are some facts:

★ More than 10 million quarters are dropped into current coin-op champ "Pac-Man" every single day.

★ Nearly 5 million programmable videogame systems are hooked up to U.S. TVs already. Four million more are expected to be sold this year alone, along with 30 million game cartridges to play on them.

★ Sales of computer games are expected to exceed 1 million units by the end of the year.

ELECTRONIC GAMES, the first—and only—magazine devoted to this booming field, is growing as fast as the high-tech hobby it covers. Our premier issue was a newsstand phenomenon, with many dealers reporting sell-outs. Our second issue promises more of the same.

So if you sell videogame systems, hand-held games, or computer games, you should also be selling ELECTRONIC GAMES Magazine. As an EG retailer, you'll earn a good profit on every copy you sell (of course, all unsold copies are fully returnable). You'll also be providing your customers with that special "extra" that will bring them back to your store again and again.

To get all the information you need to join the ELECTRONIC GAMES retailer program, fill out and mail the coupon below. There's no obligation, so do it today. ELECTRONIC GAMES Magazine is growing fast... and we cordially invite you to grow with us.

Mail to: **ELECTRONIC GAMES**  
Retailer Program  
235 Park Avenue South  
New York, NY 10003

**YES, send me information on the ELECTRONIC GAMES retailer program.**

My Name \_\_\_\_\_

Store Name \_\_\_\_\_

Store Address \_\_\_\_\_

City \_\_\_\_\_

State \_\_\_\_\_ Zip \_\_\_\_\_

My Position/Title \_\_\_\_\_

EG11

# NEW THE CONTROLLER

A unique stick shift control for use with INTELLIVISION\*.

THE BEST ON THE MARKET, BAR NONE!

ONLY \$7.95 PER SET OF 2



- Gives you the fingertip control you need to make you a superior player. Your speed, accuracy and game skills can be greatly increased through the ease of handling.
- Simple to install.

JENCO HOME ENTERTAINMENT CENTER  
3975 Amboy Road, Staten Island, N.Y. 10308

Please send me \_\_\_\_\_ sets @ \$7.95 per set.

Enclosed is \$ \_\_\_\_\_ plus \$1.00 per set for handling and postage. N.Y. State residents add applicable sales tax. (Send check or M.O. No C.O.D.'s) or, call 212-984-1198 (in N.Y.C.)

TOLL FREE: 800-221-2030 (Outside N.Y.C.)

and use your Master Card, Visa or American Express credit cards.

Name \_\_\_\_\_

Address \_\_\_\_\_

City \_\_\_\_\_

State \_\_\_\_\_

Zip \_\_\_\_\_

D

\* Intellivision is a registered trademark of Mattel, Inc.  
\*\* Not made by Mattel, Inc.

## AN ARCADE GAME FOR YOUR POCKET!

OIL PANIC

DONKEY KONG

Both games have two screen play and fold up to a compact 3"x5"x3/4"



ALL THE EXCITEMENT OF YOUR FAVORITE ARCADE GAME!

BY NINTENDO

JUST \$34.95 BY MAIL\*

SEND CHECK OR M.O. TO

Century Vending, 670 E. 3rd, Suite 106, San Mateo, CA 94401

Also New & Used Arcade Games • Pin Balls For Sale  
Write For List • Dealer Inquiries Welcome

\*Calif. Residents Add 6% Sales Tax • Price Includes Shipping

WE BUY

# WANTED!

WE SELL

USED VIDEO GAME CARTRIDGES (for Atari VCS)

Largest Dealer Of Used Cartridges In U.S.  
(More Than 60 Different In Stock At All Times)



You MUST Send A Self-Addressed, STAMPED Envelope To Receive Our Buying & Selling Price List Print Clearly.

FOREST HILLS USED VIDEO GAME CARTRIDGES  
Dept. 14, 63-56 108th Street, Forest Hills, N.Y. 11375





By THE GAME DOCTOR

**T**he old game sawbones is primed and ready to provide the answers to your toughest questions. So get out those medical insurance cards, show 'em to the Game Nurse, and we can get on with the show.

I see there are lots of good queries this month, but the T-shirt definitely

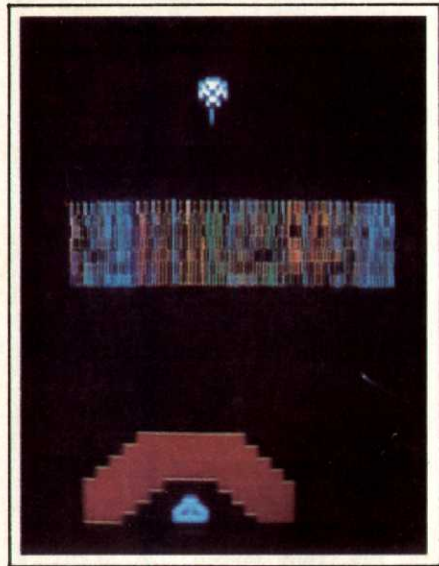

YARS' REVENGE

gets hung across the shoulders of Steve Haubner. He was not only our first reader to find the "Easter Egg" in Atari's *Yars' Revenge*, but also sent in some first-rate puzzlers. To wit:

**Q:** Lately, I have seen many strange things in arcades, such as a *Donkey Kong* game in a *Berzerk* cabinet and a *Galaga* in a *Galaxian* casing. Is this what you meant in your second issue about interchangeable games?

Also, will Coleco be making an adapter to allow it to play Intellivision games? I've also heard about a computer attachment for ColecoVision to be released at the beginning of next year (1983). Do you know what it will

cost when it's finally available?

(Steve Haubner, Cloquet, MN)

**A:** Regarding those videogames you found in the non-compatible cabinets, Steve; that wasn't what we meant by "interchangeable" games back in the second issue. They're an example of "rip-off" games of the type discussed in the October issue of *EG!* Any time you see a game in any cabinet other than its own, you can bet you're looking at a bootleg coin-op. These pathetic specimens frequently don't even correctly position the joystick.

The Game Doctor was shocked during a recent business trip when, after arriving at Kennedy Airport, I encountered a row of ten "Super Invader" cabaret-style housings. The only problem was that none of the games inside were *Super Invaders*. Instead, there were miserable copies of *Pac-Man*, *Donkey Kong*, *Frogger* and *Galaga*!

As to your second question, Coleco has no immediate plans to produce an Intellivision-compatible emulator, but an add-on keyboard peripheral will indeed appear in early '83. No price has yet been determined for the keyboard, but the Atari conversion module will

probably list for \$89.95.

**Q:** I am planning to buy a home computer, the new VIC-20. I have heard that the Atari-compatible videogame cartridges fit the VIC and I would like to know if this is true, or if you must first purchase an adapter.

I would also like to know if any other company makes VIC cartridges?

(Chip Preacher, Kettering, OH)

**A:** Sorry, Chip, but not only don't VCS cartridges fit the VIC-20, but there isn't even a conversion module available to perform that function. What is compatible, however, are the Atari VCS joysticks—and any other controllers that work on that system, including the gourmet joysticks, command consoles and paddles.

Several computer software companies have begun producing games for the VIC, but they're all on tape right now, at least until Commodore makes a disc drive available for their computer.

**Q:** I own an Intellivision game system and I saw in *EG* that Mattel is producing several cartridges for the Atari system—such as *Lock 'N' Chase* and

VIC-20





**Frogs & Flies** —that are not in the *Intellivision* catalog. Will these games be made available?

(Matt Newsome, Williamsburg, VA)

**A:** Both those titles will be available for *Intellivision* before long. *Frogs & Flies* will be released under the title

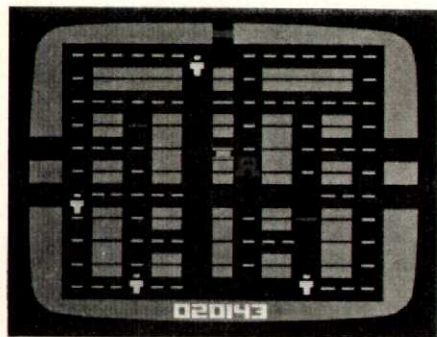

LOCK 'N' CHASE

**Frog Bog** and features extra graphic finery while Taito's coin-op maze-chase will be sold under its original monicker.

**Q:** I own an Atari VCS (2600) and I was considering selling it to buy the *ColecoVision*. Would the *ColecoVision* system improve the graphics on the VCS games? Also, is it possible for Atari to make a memory expansion unit for the VCS? Will *Imagic*, *Activision*, *Apollo*, etc. produce games for the Atari 5200? One more question —would the three software companies mentioned above make cartridges for the Atari 400/800 if I was to buy one?

(Frank Marcella, no address given)

**A:** To be honest, Frank, I think another 999,999 friends making a

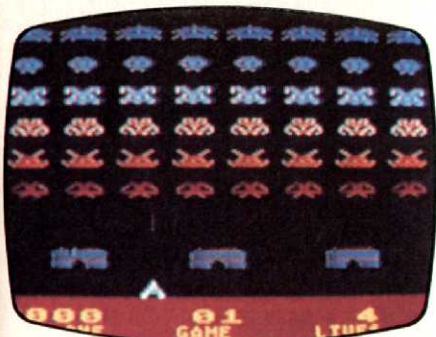

SPACE INVADERS (5200)

simultaneous 400/800 purchase would have a lot greater impact on those companies' decision about whether or not to make software for them! But if you do buy one, we'll be sure to let them know, just in case they were waiting to hear.

Seriously, though, to answer your questions one at a time: No, playing VCS games on a *ColecoVision* will not enhance their graphics. All the VCS

expansion module is, actually, is a tiny 2600 without controller boards—the *ColecoVision* sticks take over that function—that is overriding all other functions of the main console. Regarding a memory expansion unit for the 2600—doubtful, but don't forget the RAM-powered *Supercharger*, which is essentially just what you're asking for!

Games by *Apollo*, meanwhile, is already producing cartridges for the 5200, and at least one title should already be in the stores as you read this.

**Q:** I own a *Mattel Intellivision* and I'm planning on getting the keyboard. I would like to know if I could program my own games on it.

(Allen Johnson, Nevada, IA)

**A:** To be perfectly honest, I can't really prescribe the current *Mattel* keyboard for would-be game designers. It just does not have the raw materials to produce first-rate action games and high quality audio-graphics.

A little bird, however, has whispered a rumor in our ear to the effect that *Mattel* will soon be producing a smaller, but totally compatible, version of the *Master Component*, for which they may design a brand new type of keyboard. So sit tight for a month or so, Allen, and let's both see what transpires.

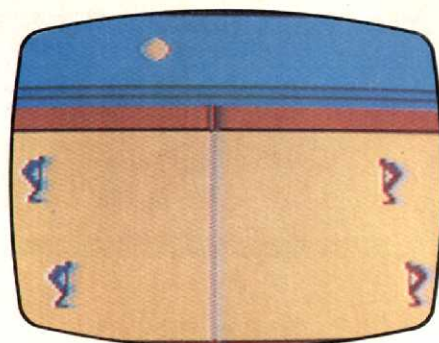

ATARI'S VOLLEYBALL

**Q:** As a sports enthusiast, I enjoy playing the sports games on my Atari VCS, but I'm somewhat disappointed

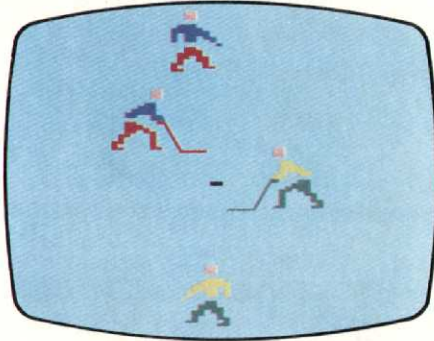

ICE HOCKEY

in the graphics and play quality of games such as **Home Run** and **Football**. Why hasn't a software company such as *Activision* or *Imagic* tried to



MATTEL SYSTEM



# ANALOG COMPUTING

THE FIRST MAGAZINE DEVOTED ENTIRELY TO THE ATARI!



EACH ISSUE CONTAINS:

- GAMES
- REVIEWS
- UTILITIES
- EDUCATION
- TUTORIALS
- PROGRAM LISTINGS
- NEW PRODUCTS
- VIDEO GAME UPDATE



ATARI IS A T.M. OF ATARI INC.

SUBSCRIBE TODAY!

1 yr. subscription (6 issues) \$12.00



**A.N.A.L.O.G. COMPUTING**  
P.O. BOX 615, HOLMES, PA 19043



CALL TOLL FREE: 1-800-345-8112

upgrade the line up of sports cartridges? Will I see new, improved sports games in the future?

(Brian Colter, Dearborn, MI)

**A:** Actually, Brian, in addition to Atari's strong *Pele' Soccer*, Activision offers such excellent sports games as *Tennis*, *Skiing* and *Ice Hockey*. Not only are all four of these games excellent, they can even be played solitaire.

Still, for fans of the more traditional team sports, the brilliant M-Network cartridges for the VCS should more than calm your fevered brow. So insert those carts and play ball!

**Q:** Is the amount of memory in "K" comparable in both coin-op and micro-computer games?

(Tom Yanichko, Monroeville, PA)

**A:** Good question! Up until about a year ago, the vast majority of commercial arcade games were a "mere" 16K—8K for the game itself, with an equal number of K for the so-called "attract mode", the automatic play that's on screen when the game is not in play.

Today's coin-ops commonly use a full 48K of program, just as today's top home micro computers also boast a 48K capability. There are differences, however. Coin-op games, as we've said many times, are designed to play one game. They can employ special transparent screen overlays, special voice chips and even tape recordings.

Computers, on the other hand, are well, computers, and they have to do everything from balancing the checkbook to monitoring the stock market—all in addition to being able to play super videogames. The point where home-generated rasterscan graphics reach coin-op quality, however, seems very close indeed.

**Q:** I am an Intellivision owner and I would like to know if you have to shut off the computer before putting in or taking out a cartridge. If you don't, what happens?

(John Robel, Chicago, IL)

**A:** When a game cartridge is inserted into the slot on a system which is turned on, a circuit has been completed. Breaking that circuit by removing the cartridge without shutting down the power first, causes a shock to the entire system. A series of these shocks could eventually damage the unit, while simply cutting the power first should indefinitely prolong the life of any microprocessors that might otherwise get thrown out of whack.



An ideal gift for the person who has everything!

Send \$2 for Catalog and latest Newsletter telling what's coming in video games.

For Phone Orders only:  
(Visa or MasterCard only)  
1-800-626-9592

\$2.00 per item shipping charge. California residents add 6-1/2% sales tax. (Canadian orders in U.S. funds only. Add \$5.00 shipping charge.) We ship 90% of all orders within 24 hours.

## X-RATED!

Mystique™ presents  
**Swedish Erotica™**

The World's First Adult Video Game Cartridge. A concept whose time has come. Featuring

graphics, songs, sound effects, action and packaging unparalleled by any Atari-compatible game cartridge on the market.



Players are in for a heck of a good time!

**CUSTER'S REVENGE™**  
**BACHELOR PARTY™**  
**BEAT 'EM AND EAT 'EM™**

Limited edition cartridges. \$49.95 each.

Dealer Inquiries welcome.

6626E Valjean Avenue • Van Nuys, CA 91406  
For further information only (213) 781-1300  
Stores throughout Southern California

**G.A.M.E.S.™**

©1982 G.A.M.E.S.

"LEFTY"  
Joystick Adapter  
by Suncom™

Allows left-handed players to use any Joystick made for Atari\*

Only \$6.95  
Also 5' Joystick extension cable \$5.95





# AMOK



## UMI games...for the fun of VIC<sup>®</sup>

You've braved the perils of space and landed on the isolated space station AMOK, populated by killer robots! Their only directive is to destroy the invader! The cunning robots stalk you from all sides, evading your most deadly shots. You'll run and shoot from the hip to protect yourself. Stop moving . . . and the diabolical robots will destroy you.

AMOK is just one of UMI's many action-packed arcade-quality games.\* This challenging adventure will keep you locked in an hours-long battle for survival against life-threatening robots. United Microware games come on either cassettes or UMI's own durable cartridges, depending

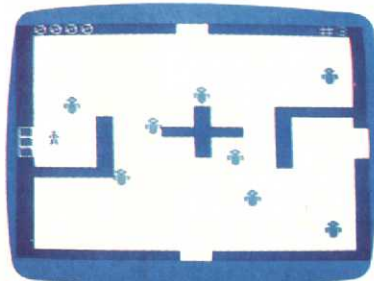

on your game selection. If you're ready for thrilling, out-of-this-world adventure, look to UMI. Send for the latest UMI catalog and contact the UMI dealer nearest you today . . . after all, it's just for the fun of VIC<sup>®</sup>!!

United Microware Industries, Inc.  
3503-C Temple Avenue  
Pomona, CA 91768 (714) 594-1351



\*More action-packed UMI games: Meteor Run — 1613, Renaissance — 1600, Alien Blitz — 1619

VIC is a registered trademark  
of Commodore Business Machines





## Will Flipper Games Boom in 1983?

By ROGER C. SHARPE

As the year draws to a close, it's easy to understand why diehard pinballers have had little to flip over. In looking back at 1982, the undeniable truth is that pinball machines have journeyed through a dramatic period of transition which has set the stage for its continued survival or a place as a historical footnote in the evolution of the coin-machine industry.

To borrow a line from Mark Twain, the reports of pinball's death are greatly exaggerated. In fact, although some might consider the past 12 months to have been the worst of times, they will also be remembered as having been the best of times. After all, we've witnessed the creation of a breakthrough effort—Gottlieb's **Caveman**—which married the play action of both pinball and video in one game, the singularly different and perplexing bumps and rolls of Stern's **Orbitor 1** with its molded, contoured playfield and, lastly, the attempt to package a new breed of game in a pinball cabinet ala Williams' **Hyperball** and Bally's **Rapid Fire**. And the year isn't even over yet.

Whatever the coming months will bring, pinballers have been treated to some very diverse challenges as manufacturers continue to pull out all stops

in the hope of finding that magic formula. Even this month's machines offer a hint as to the imaginative options still open in the design and programming of a pinball playfield.

### **COSMIC GUNFIGHT**

*Williams*

Though this company has garnered most of its kudos over the past couple of years because of its videogames, Williams still remembers its heritage and, although the intensity and primary focus is not what it once was, the effort remains to turn out pinball machines. In this case, their most recent game, **Cosmic Gunfight** is a bit deceiving because there's more than meets the eye in looking over the features and layout of the board.

With a variety of shots and fairly good balance from top to bottom, **Cosmic Gunfight** is a game for pinball purists, or as Williams is calling it, a "back-to-basics" machine with something for everyone. All in all, the conventional design, which does not bring into play a third or even second level of action, does incorporate multi-lane change (activated by the flipper buttons), multi-ball play and a potential of cosmic ball play which is really an added-on bonus turn tied into

features on the board, and values collected during the course of play.

Destined to probably endure the same fate as Gottlieb's **Devil's Dare**, which on the surface didn't look like much to those within the industry but did gain a dedicated following at many locations, **Cosmic Gunfight** is going to get its fair share of quarters from those willing to invest in a few plays and test their skill.

The action begins with three top lanes (1-2-3) on the right side and leads down to a middle area of four thumper bumpers spread out from left to right. Over at the top left is a kick-out hole for possible locking up of a ball and two more lanes, while the right has an underpass for access back up to the top and that all-important rest period. Moving down, there's the main activity of the game with a three-bank of drop targets on the extreme left and right as well as two more sets, separated slightly, at mid-field. The final touch is a deeply recessed left side kick-out hole and more than enough play for left to right or right to left flipper shots, as well as ample reverses to all key areas.

With an array of lights and arrows all over the board, the left side, center drop target bank is the place for



players to gain possible "cosmic ball" time units by completing the targets and filling out a fronting nine-spot square of A's, B's and C's. Then, when regulation play is over, any amount of "bonus" time accumulated means that much *more* of an opportunity for extended flipping, plus additional points and even specials.

The playfield features may reflect a design sensibility that's a throwback to another era, but taken in total with the programming capabilities tied in, *Cosmic Gunfight* is right on target for these times and any self-professed sharpshooters looking for a new challenge.

## SPECTRUM

Bally

When it comes to pinball design, Bally continues to stretch beyond the imagined boundaries of just what conventional playfield features can accomplish by loading up the programming to bring pinballers something more than they might have expected. So it is with *Spectrum*, which deviates from the norm on a number of different levels.

First off, in order to get a better idea of the madness behind the method of *Spectrum*, you should think of it as "Master Mind meets Pinball", because once you play the game, it's obvious where the inspiration came from. In fact, the features on the board are all color-coordinated, with players trying to 'discover' which of the 256 color code combinations the game computer has selected. With all the possibilities, it's no mean feat to "break" one code, let alone the new ones which will follow during the course of play.

The appropriate lighting effects have all been added as well as the incorporation of speech to help in the quest, but *Spectrum* is, indeed, something out of the ordinary. There's a symmetrical playfield, with a top center kick-out hole and, just below, two drop target banks (green and yellow). Even the spinners on either side as well as two more drop target banks (red and blue), along with kick-out holes at left and right, won't strike pinballers as being so startlingly diverse, but there's more. (This always seems to be the case, doesn't it?)

Looking closer, you'll immediately notice the absence of a plunger, since the ball gains entry onto the field once the right flipper button has been pushed. Then from the middle depths



COSMIC GUNFIGHT

of the game, pops out the pinball. The center of the board is a color-keyed set up of rows of lights. Then comes the sudden recognition that *Spectrum* features no thumper bumpers or even kicking rubbers to compensate for those times when flipper accuracy is lacking and help is as close as the next little playfield component.

It's all skill here, a true test of ability and timing that is amplified by the fact that landing in the top kick-out hole, or racing through either spinner, will almost instantly mean the appearance of a ball from either the bottom left or right side—shot out toward your flippers and ready for your follow-up move.

The result is a rather unique experience and sensation when compared to

more conventional pinball machines and that's just in terms of the play. Add the ever-present need to "pick a clue" (which is audibly offered) and break the code in order to achieve increased point totals, and there's more to *Spectrum* than might be suspected at first glance. And to cap it all off, you can never predict just what you'll need to get over the top from game to game.

And that's the way the newest machines stack up as we get ready to usher in a new year and, hopefully, more variations on the theme of just what pinball can bring to all players the world over. Just tilt your attention to this form of coin-op entertainment and see what I mean. It might be enough to keep you flipping out for more.



## SPIRIT

Gottlieb

If there's one manufacturer which has remained faithful to pinball, it's Gottlieb and, although they've dedicated a considerable amount of manpower and financial support to set up a functioning videogame development facility and have turned out some original efforts, the energy spent on flipper machine design hasn't abated. It's a fact that becomes increasingly clear with each succeeding model they produce and *Spirit*, their newest, is no exception.

In fact, the effect this time around is kind of overpowering from the spinning middle portion of the backglass right down to the full-loaded double-level playfield with its subtle design touches and integrated action. Entry off the plunger is to a left side area with a kick-out hole above and three lanes below, leading down to a single thumper bumper and a small flipper just to the right. Fronting this is another kick-out hole, while the right side offers yet another for possible three-ball, multi-ball play, if made in sequence according to an amber indi-



SPIRIT

# Wanna Be A Videogame Insider? Subscribe To **ARCADe EXpress**

Read the hottest news of your favorite hobby in *Electronic Games Magazine's Sensational Bi-weekly Newsletter!*

When executives in the electronic gaming world want the lowdown on the latest developments in their field, they turn to **Arcade Express**, the bi-weekly newsletter from the same folks who bring you *Electronic Games Magazine*. It's a "must read" for gamers who really want to be in the know about their favorite hobby.

**Arcade Express** zooms into your mailbox every two weeks, packed with hot-off-the-press news about every facet of electronic gaming—programmable videogames, stand-alone devices, computer games and coin-ops. Plus, **Arcade Express** presents the inside, behind-the-scenes news of the major corporations that make up the videogame industry. Best of all, **Arcade Express** gets

you the big stories while they're still hot!

Each eight-page issue also features dozens of non-sense reviews of all the latest games. First, fast and factual—just what you'd expect from *Electronic Games*. But with **Arcade Express**, you'll know what's really happening almost as fast as our editors find out.

**Arcade Express** will never be available on any newsstand, but you can get it home delivered for a substantial saving over the single-copy price of \$1.50. **Get six months of Arcade Express—13 bi-weekly issues—for just \$15.00 (save \$4.50) or subscribe for a full year—that's 26 issues—for the low price of \$25 (save \$14.00).**

Don't end up on the outside looking in,  
read the latest news in  
**Arcade Express** every two weeks!

## Join the Electronic Gaming Elite—Subscribe Today

Mail to: Arcade Express  
P.O. Box 3000—Dept. K  
Denville, NJ 07834

Yes! Make me a **subscriber** to Arcade Express!

- Send me six months (13 issues) of Arcade Express for \$15.00 (save \$4.50)  
 Send me a full year (26 issues) of Arcade Express for \$25.00 (save \$14.00)

Name ..... Please Print

Address .....

City ..... State ..... Zip .....

Enclosed is my payment of.....

Please make all checks payable to: Reese Publishing Company

cator light.

Back up the middle, in the top portion of the board, is a small roundabout (or horse show) and a center "stargate" ramp, originally introduced on Gottlieb's *Mars*, which can either be moved down for access up to the top level or raised for immediately activating either two- or three-ball play. As for that top level, over at the right side, there's a single target and flipper, as well as a three-bank of drop targets and a fronting ramp for additional entry from the lower board or, more often than not, a roll-down back to the main field of play.

If that weren't enough to put the most accomplished pinballers to the test, *Spirit* brings into play yet another ingenious design touch with the inclusion of an extra set of flippers at the base of the bottom, outside lanes for a last chance gasp at keeping the ball in play—activated by an extra set of flipper buttons on the side of the cabinet.

There's seven-digit scoring, bonus multiplier values up to 6X and more than enough action to keep players coming back for more. It's a challenge to master a set strategy of play, but if the "spirit's" willing, then *Spirit's* sure to keep you flipping again and again.





Continued from page 22

and scampered up the side of a half-finished skyscraper. To get her back, Mario must work his way up the edifice, using ladders and elevators to ascend to the lofty perch where Donkey Kong sits with his human prize. Pushing the joystick to the left or right moves Mario back and forth along any horizontal girder, while pushing the stick forward or back will allow Mario, when correctly positioned, to climb up or down a ladder.

It wouldn't be much of a game if our hero didn't have to overcome some obstacles, and the ones in *Donkey Kong* are dillies. Mario must leap over or dodge flaming barrels or intelligent fireballs as he moves through the game's three phases toward his goal of rescuing his lady love.

*Cosmic Avenger*, based on the Universal commercial arcade game, is hardly less of a success than the ape game. The arcader captains an air-and-sea fighter in the scrolling shoot-out. The gamer uses the action buttons to fire the nose-mounted laser and drop bombs in an effort to fight through three scenarios.

First, the arcader must pilot his craft through the perilous skies of a super-scientific city bristling with missile launchers. Adding to the conflict in this portion of the game is a fleet of UFOs which fire missiles at the ship. A radar screen located at the top, center of the display helps keep track of the movement of the flying saucers, but it can sometimes be a little hard to read in the heat of battle.

The second phase is a vast plain dotted with mesas. The UFOs fly air cover for shell-firing tanks that cruise along the ground. If you get through that without exhausting your supply of five ships, it's time to head beneath the waves for some undersea combat. You must explode or maneuver around the mines, while dueling with torpedo-firing submarines and missile batteries.

*Venture* is just as fast-paced as *Cosmic Avenger*, but it's a totally different gaming experience. Introduced in the commercial fun palaces by Exidy with some success, this contest of fearsome monsters and priceless treasures may well come into its own in this home edition. Now players have the chance to really delve deeply into what is a taxing strategic challenge.

*Venture* casts the arcader in the role



A quality 10' extension cable for Atari type joysticks.

Fits: Atari® , VCS™, Sears TeleArcade™, Atari 400, 800 and VIC 20™ home computers.

MADE IN USA WITH HIGH QUALITY MATERIALS.

Ask for JOYLINK™ at your local games dealer.

OR

order direct by certified check, money order

Michigan Residents add 4% sales tax

**\$14.95** each

CABLE CONCEPTS, INC. P.O. Box 427 Fraser, MI 48026 313-293-3911

DEALER Inquiries Invited · IMMEDIATE SHIPMENT



## For Programmers Who Want To Be Software Stars.

So, you want to design and develop exciting and entertaining software for hundreds of thousands of Atari home computer users? Here's your chance to do just that.

You'll experience the fun, the excitement, and the rewards of working with the leader in electronic entertainment. You've got to have 1-3 years' experience programming an 8-bit micro. And you must know Assembly thoroughly, as well as write code faster than PAC-MAN™ gobbles power pills.

You'll be working at the outer limits of game software technology with some of the industry's most brilliant people. Plus you'll have the chance to write yourself into software history.

Why wait? The future beckons you to Atari. Call Jim Rook COLLECT at (408) 942-3947. Or, send your resume to ATARI, INC., Human Resources, Dept. OSKB4, 30 E. Plumeria Drive, San Jose, CA 95150. We are an equal opportunity employer.

**ATARI®**

A Warner Communications Company

**DISCOVER HOW FAR YOU CAN GO.**



of the cute-but-intrepid hero Winky. Armed with a bow that can be fired by hitting the action button, Winky must explore a multi-level labyrinth. Each level has four rooms, and each room holds a specific prize and a set of monsters to guard it. Winky must zip down corridors, avoiding the invincible hall-monsters, and enter each room in turn. Once inside, it is the player's option to either blast a path to the booty or try to out-manuever the guardian creatures. When an electronic explorer has put all four prizes on a particular floor into his hoard, the program moves him to the next set of four more difficult chambers.

Again, Coleco has created a home cartridge that is, for all intents and purposes, comparable to the quarter-snatcher of the same title. Each set of monsters has its unique method of attack, and there's a different theme song for each room on any given floor.

At this point, Coleco has announced plans to produce 22 game cartridges for its new system by mid-1983.

The ColecoVision library can fairly be characterized as highly dependent on home translations of arcade machines. Titles in this category in-

clude: **Zaxxon** (Sega), **Mousetrap** (Exidy) and **Turbo** (Sega). There'll also be a pair of sports simulations, **Head-to-Head Baseball** and **Head-to-Head Football**, as well as adventure cartridges based on the non-electronic "Tunnels & Trolls" role-playing game and the Smurfs cartoon characters.

Absent, at least from the announced schedule, are any plans on the part of Coleco to design many original arcade-style action games for its system. Presumably, several independent software publishers will be more than thrilled to fill this gap.

In many ways, ColecoVision is the best new videogame system introduced since Atari brought forth the VCS back in 1978. If Coleco is able to harness its mammoth potential, the first of the "third wave" systems may turn out to be the home arcaders' top choice for the mid-1980's.

## GAME DESIGNER

Continued from page 36

eodiscs will change games and game designing into something different, exciting and worth waiting for.

MUSE's Warner predicts, with some concern, that as the influence of entertainment conglomerates grows, we will see the development of "assembly line" games design. Other experts foresee the use of special tools like "author" languages that will permit people with no programming ability to create computer games.

Whatever the future, today one thing is sure: Game designing is in its infancy. Few "right" answers exist. As Silas Warner puts it: "No advice is perfect because it's all such a new thing."

## ULTIMATE GIFT

Continued from page 96

do gain an extra portable color TV in the process. One that could serve you especially well if you also own a portable VCR and video camera. This is an ideal on-location monitor. But if your interest is limited to videogames, you might find the price a bit steep.

For all of you well-heeled Santas out there this is the gift of choice. For those who cannot afford the system as shown, consider working with alterna-

# NOW! YOU CAN ORDER DIRECT FROM telesoft, inc. & SAVE:

**FREE!**  
STICK STAND  
with FASTBALL



**NEW!**  
REDUCES  
HAND  
& WRIST  
FATIGUE



(With purchase of \$60<sup>00</sup> or more. A \$6<sup>99</sup> value!)



**APOLLO**  
Lochjaw \$24.80  
Lost Luggage 24.80  
Racquet Ball 24.80  
Space Cavern 24.80  
Spacechase 24.80  
Sneak Shoot 18.00

## ACTIVISION



Pitfall \$24.25  
Megamania 24.25  
Starmaster 24.25  
Chopper Command 24.25  
Grand Prix 24.25  
Barnstorming 24.25  
Ice Hockey 24.25  
Stampede 18.00  
Kaboom 18.00  
Freeway 18.00  
Laser Blast 18.00  
Tennis 18.00  
Bridge 24.25  
Skiing 18.00  
Fishing Derby 18.00

## COLECO

ColecoVision \$188.95  
Donkey Kong 30.50  
Zaxxon 49.75  
Turbo 69.00  
Smurf Action 30.50  
Space Fury 30.50  
Venture 30.50  
Mouse Trap 30.50  
Lady Bug 30.50  
Cosmic Avenger 30.50  
Las Vegas 30.50  
Horse Racing 30.50  
Carnival 30.50  
Coleco For Atari CALL  
Coleco For Mattel CALL

## K&C'S

Odyssey<sup>2</sup> Video Game \$165.00  
K.C. Munchkin 28.00  
Quest For The Rings 44.00  
U.F.O. 28.00  
Pick Axe Pete 28.00  
Freedom Fighters 28.00  
Smithereens w/voice 44.00  
K.C.'s Crazy Chase w/voice 44.00  
Acrobat w/voice 44.00  
Creature w/voice 44.00  
Arcade w/voice 44.00  
Las Vegas Blackjack 20.00  
Football 20.00  
Armoured Encounter 20.00  
Bowling/Basketball 20.00  
Math-A-Magic 20.00  
Baseball 20.00  
Computer Golf 20.00  
I've Got Your Number 14.25

## PARKER BROTHERS

Frogger \$27.60  
Star Wars 27.60

## IMAGIC

Demon Attack \$23.00  
Star Voyager 23.00  
Cosmic Art 23.00  
Riddle of The Sphinx 23.00  
Atlantis 27.90  
Trick Shot 18.00  
Fire Fighter 18.00

## SPECTRAVISION

China Syndrome \$21.10  
Tape Worm 19.90  
Word Zapper 21.10  
Planet Patrol 19.90  
Gangster Alley 21.10

## MATTEL ELECTRONICS INTELLIVISION



Astroslash \$26.00  
Major League Baseball 26.00  
Star Strike 31.00  
Sea Battle 31.00  
Advance Dungeons & Dragons 31.00  
Space Spartans 34.75  
Tron Deadly Disc 26.00  
NBA Basketball 26.00  
P.B.A. Bowling 26.00  
Sub-Hunt 26.00  
SnuFu 26.00  
Space Hawk 31.00  
Utopia 31.00  
Night Stalker 31.00  
N.F.L. Football 26.00  
Pin Ball 21.75  
Auto Racing 26.00  
All Others CALL

## vidtec

Maze Chase \$22.90  
Gopher Attack 22.90  
Towering Inferno 22.90  
Weird Bird 22.90  
Commando Raid 22.90  
Word Zapper 22.90  
Sneak 'N' Peck 22.90  
Space Jockey 18.50

## ATARI



Defender \$28.50  
Pac-Man 28.50  
Adventure 24.25  
Yars Revenge 24.25  
Missile Command 24.25  
Berserk 24.25  
Maze Craze 20.50  
Super Breakout 18.00  
Dodge 'Em 18.00  
War Lords 24.25  
Superman 24.25  
Space Invaders 24.25  
Video Pinball 24.25  
Casino 20.50  
Adventure 1 28.50  
Adventure 2 28.50  
Star Raiders 28.50  
All Others CALL

## ACCESSORIES

Stick Stand \$ 6.99  
2 For 12.00  
Atari Joy Stick 6.20  
Wico Joy Stick 22.50  
Wico Red Ball Joy Stick 24.80  
Wico Track Ball 22.50  
Atari/Commandor 52.00  
Many More Accessories CALL

COMPLETE  
COMPUTER  
LINES...  
CALL!

Bell & Howell



Texas  
Instruments



## ORDERING INFORMATION

Check, Money Order, MasterCard, Visa and C.O.D. orders accepted. All orders shipped U.P.S. collect. Michigan residents add 4% sales tax. Hours 9 a.m. to 8 p.m. daily.



**tele soft, inc.**  
P.O. Box 3456, Troy, MI 48084

CALL FREE 1-800-255-2000 IN MICHIGAN 1-800-742-4242





# WIZARD VIDEO GAMES™ ANNOUNCES A NEW WAY TO TAKE OUT YOUR FRUSTRATIONS!

**THE FIRST VIOLENT AND ADULT VIDEO GAMES.**  
For the Atari® Video Game System and Sears Video Arcade.

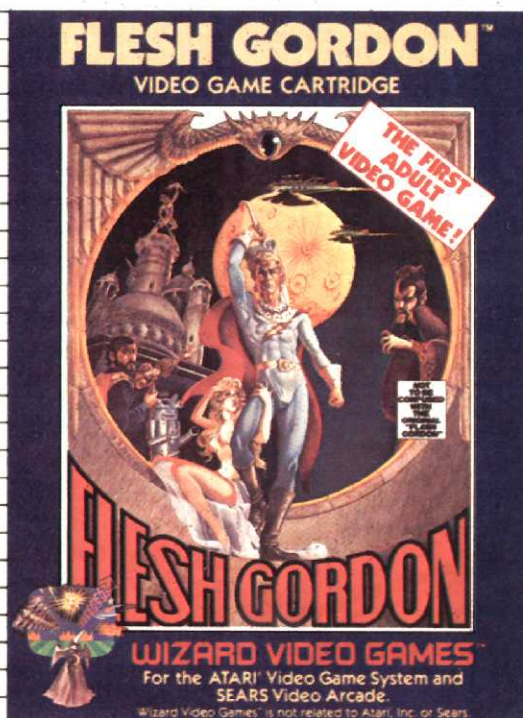

Put aside your childish pastimes; stop eating dots and chasing ghosts...THE TEXAS CHAINSAW MASSACRE is a violent videogame that lets you play the part of the vengeful Leatherface, or an innocent victim looking for safety. Know the pleasures of total destruction as you put yourself in the classic horror movie...the first violent videogame; THE TEXAS CHAINSAW MASSACRE.

Become FLESH GORDON, the immoral doer of good, in the first ever adult participatory game, as you travel the underground labyrinths of the planet Porno. It will take power and cunning to survive the perverse traps of his protruberance, Wang. Do so and win the favors of the lovely Dale Ardor...grab your joysticks and play the hottest game on earth!...FLESH GORDON.

## Coming for Christmas '82



For more information contact your Wizard Video Games™ distributor.  
Or, Wizard Video Games™, 1119 N. McCadden Place, Los Angeles,  
California 90038, Telephone (213) 462-2636.

Wizard Video Games™ is not related to Atari, Inc. or Sears.

©1982 Wizard Video Games™  
All Rights Reserved



## Video Game Cartridges And Computers At Wholesale Prices

**Savings Up To 50%  
Off Retail Prices**

ATARI	ASTROCADE
ACTIVISION	U.S. GAMES
MATTEL INTELLIVISION	SPECTRAVISION
COLECO VISION	PARKER BROTHERS
ODYSSEY	20th CENTURY FOX
IMAGIC	APOLLO

**NO** Clubs to Join  
Membership Fees  
Gimmicks

Thanks to our thousands of loyal customers we have expanded our list to include computers and computer software along with the largest selection of video game cartridges anywhere.

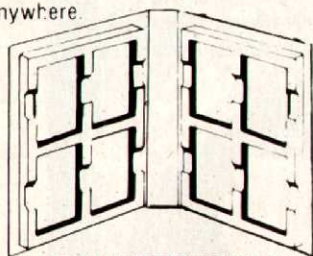

**VIDEO GAME STORAGE ALBUM**  
Holds 8 Video Game Cartridges  
ONLY 4.50 plus 1.50 postage & handling  
Indicate video cartridge system.

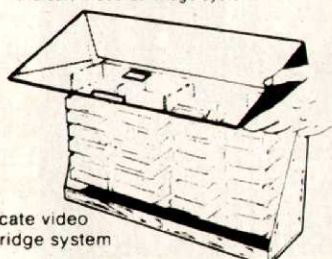

Indicate video  
cartridge system

**VID-RAK Holds 28 Video Game Cartridges**  
ONLY 10.50 plus 1.50 postage & handling



Enclose 50c  
for our new complete  
catalog of all the latest  
and upcoming video  
cartridges, video acces-  
sories, computers, and  
computer software.

**ONLY 3 WEEKS DELIVERY ON ORDERS**

WE ACCEPT VISA & MASTER CHARGE  
Canadian residents please pay in US currency.

ACCOUNT NO. \_\_\_\_\_

DATE EXPIRES \_\_\_\_\_

SIGNATURE \_\_\_\_\_

NAME \_\_\_\_\_

ADDRESS \_\_\_\_\_

CITY \_\_\_\_\_

STATE \_\_\_\_\_

ZIP \_\_\_\_\_

**COMP-U-GAMES**

P.O. Box 7105

Hicksville, New York 11801

Xerox copy of this ad may be used as order blank.

tive TVs and battery packs.

If you decide to go ahead with this project, remember the most difficult task will be fashioning the foam liner for the case. If you employ pluck-foam option, the job should take less than two-hours. That little bit of work and ten minutes of a serviceman's time will allow your Christmas present to take a giant step into the future, leaving the rest of us in the past. G

## STAND-ALONE SCENE

*Continued from page 104*

last. While technology at this stage probably can't support a larger version of such an ecologically sound game, the sun seems an ideal power source for small hand-held units. *Invaders of The Mummy's Tomb* and *Escape From The Devil's Doom* may not be the most complex electronic games in the world, but they are nice novelties. They're palm-sized, have fast action and cute animation, and definitely rate as the newest things under the sun!

## CASIO VL-5

Casio/\$150

You say you can't read a note, but you've got a song in your heart? You've never touched a piano, but your fingers are itching to tickle the ivories? You mean you'd like to dash off a ditty, but musically your hands have two left feet? Well, here's a solution to your problem—a way to make music with a little help from technology.

The *VL-Tone* keyboard, introduced by Casio in 1981, filled a gap in the market by offering a low-priced keyboard that fits one hand comfortably, while also proving to be lightweight and easily portable. The *VL-Tone* boasts five voices and 10 rhythms. This tiny keyboard packs another powerful surprise. A tiny recorder built into the unit allows you to pick out a song one note at a time, then play it back automatically at the pitch, tempo and voice desired.

Now the *VL-Tone* keyboard has fathered the next generation of tiny musical instruments, the *Casio VL-5*. The *VL-5* takes all the features of the first unit, then goes further. You can now choose from 16 voices: flute, bagpipe, clarinet, violin, trumpet, pipe organ, harpsichord, piano, pretty and funny. Eight rhythms built into the unit add automatic accompaniment to your

tune, whether you prefer waltz, march, rock, swing, samba, rhumba, slow rock or metronome. The keyboard has three full octaves, and it's possible to chord up to four notes simultaneously.

The *VL-5* recorder works like its predecessor. The unaccomplished musician plays one note at a time, deleting errors if his fingers stumble onto wrong keys, then hears his masterpiece played back one note at a time. The musician controls the tempo and adds the automatic rhythm background to his composition. For a smoother, more professional-sounding playback, use the auto play key. The beat will be automatically matched to the music. Even if you don't have rhythm, this unit does!

All of these are good features. But the technological wonder of the *VL-5* is Casio's addition of a bar-code reader to the *VL-Tone*, making the *VL-5* into the world's first midgit player piano!

The bar-code reading wand plugs into the back of the keyboard. Special music books, available from all Casio keyboard dealers, contain songs coded for reading by wand. The music looks vaguely like the UPS code found on all grocery items. When the wand is passed over a line of the bar code, it is stored into the keyboard's memory. Press the playback key, and real professional music pours from the unit's speaker.

To use the wand, place the music book on a flat firm surface. Pass the wand over each line of bar coded music in a quick flowing motion. If the music is read properly, the unit signals with a tinkle. An incomplete reading produces a gong. Continue in this fashion until all the music is read into the *VL-5*, then play back the recorded melody as desired.

Unfortunately, music recorded either manually or from the bar-coded songbook that comes with the unit is very simple, one-note melody lines. To gain musical depth, it would be necessary to play harmonic notes against this, something that might not be possible for untalented fingers. But the recorded rhythms help this deficiency.

The *VL-5* is a lot of fun. Its portability makes it a delight to travel with, and the recording features have real use for a musician trying out a composition. But the most fun of all is the bar-code reader. After all, even if the music that ensues is a little thin, everyone likes player pianos. And this is certainly the tiniest one we've seen so far. G



# VIDEO DELIVERY

**XMAS SALE!** Prices Good Through 12-31-81

**OUR PRICES CAN'T BE BEAT!**

<b>Atari</b>	Conversional Spanish	48.86
<b>Master Component</b>	Energy Czar	12.86
ET (Dec)	Euro. Countries & Capitals	12.86
Air Combat	Hangman	12.86
Super Breakout	Invitation to Programming 2	24.86
Space War	Invit. to Programming 2	24.86
Outlaw	Invit. to Programming 3	24.86
Star Racers	Juggles House	12.86
Canyon Racers	Juggles Rainbow	12.86
Super Breakout	Kingdom	12.86
Defender	Music Composer	34.86
Warlords	My First Alphabet	28.86
Invy 500 (w/controllers)	Scram	20.86
Street Racer	States & Capitals	12.86
Adventure	Touch Typing	20.86
Diamonds to Demons		
Pele's Soccer		
Backgammon		
3-D Tic Tac Toe		
Video Olympics		
Breakout		
Home Run		
Basketball		
Football		
Human Cannonball		
Bowling		
Sky Diver		
Circus Atari		
Superman		
Space Invaders		
Night Driver		
Golf		
Maze Craze		
Video Checkers		
Dodge 'em		
Missile Command		
Othello		
Fox Bat (Dec)		
Surround		
Earthworld (Nov)		
Codebreaker		
Video Chess		
PacMan		
Video Pinball		
Asteroids		
Berserk		
Casino		
Haunted House		
Yar's Revenge		
Earthworld (Nov)		
Fireworld (Nov)		
Airworld (Dec)		
Waterworld (Dec)		
Math Grand Prix		
Star Raiders		
Hangman		
Brain Games		
Street Racer		
Baseball		
Volleyball		
Frog Pond		
Phoenix (Dec)		
Vanguard (Dec)		
Raiders of the		
Lost Ark (Dec)		
Realsports (Dec)		

<b>Supersort</b>		17.86
T (Text Display)		17.86
Text Editor		31.86
Ultimate Renumber		17.86
Utility Disk		38.86
Word Processor		38.86
<b>We Service Atari</b>		
<b>Video Games</b>		
<b>Activision</b>		
<b>Fits Atari</b>		
Dragster		18.86
Boxing		18.86
Checkers		18.86
Pitfall		24.86
Magamania		24.86
Fishing Derby		18.86
Skunk		18.86
Bridge		24.86
Tennis		18.86
Laser Blast		18.86
Freeway		18.86
Kaboom		18.86
Stampeed		18.86
Ice Hockey		24.86
Runstomping		24.86
Chopper Command		24.86
Starmaster		24.86

<b>General Programs</b>		
Word Processor		122.86
Bond Analysis		20.86
The Bookkeeper		122.86
Graph It		18.86
The Home Filing Manager		40.86
Mailing List		20.86
Mortgage & Loan Analysis		16.86
Personal Fin. Management		1.68
Statistics I		16.86
Stock Analysis		20.86
Stock Charting		24.86
Teletink II		24.86
Teletink II		24.86
Cubbyholes		25.86
Mapware		17.86
Number Blast		12.86
Starware		17.86
Video Math Flashcards		12.86
Wordmaker		12.86
Bowler's Database		12.86
Data Management System		17.86
Family Budget		17.86
Family Cash Flow		17.86
Family Vehicle Maint.		17.86
Receipt Search 'n' Save		17.86
Weekly Planner		17.86
Advanced Music System		23.86
Banner Graphics		12.86
Keyboard Organ		17.86

<b>Activision</b>		
<b>Fits Atari</b>		
Pitfall (Dec)		24.86
Stampeed (Dec)		24.86
<b>Imagic</b>		
<b>Fits Atari</b>		
Trick Shot		18.86
Demon Attack		23.86
Star Voyager		23.86
Atlantis		23.86
Fire Fighter		18.86
Middle of the Sphinx		23.86
Video Action Center		31.95

<b>Kits and Assortments</b>		
The Educator Kit		136.86
The Programmer Kit		59.86
The Communicator Kit		358.86
The Communicator Kit II		1.68
The Entertainer Kit		76.86
The Home Manager Kit		1.68
The Bookkeeper Kit		203.86
Personal Interest Asmt		84.86
Educator Assortment		1016.86
Entertainment Asmt		979.86

<b>Entertainment Programs</b>		
Astrosky		17.86
Attack!		17.86
Avalanche		17.86
Babel		17.86
Blackjack Casino		12.86
Blackbuster		12.86
Dog Daze		17.86
Domination		17.86
Downhill		17.86
Eastern Front (1941)		12.86
Graphic/Sound Demo		17.86
Outlaw/Howitz		17.86
Reversi II		17.86
Salmon Run		17.86
Seven Card Stud		12.86
Solitaire		12.86
747 Landing Simulator		17.86
Asteroids		29.86
Basketball		29.86
Clavens of Mars		12.86
Centipede		36.86
Computer Chess		29.86
Missile Command		29.86
Pac-Man		36.86
Space Invaders		29.86
Star Raiders		36.86
Super Breakout		29.86
3-D Tic-Tac-Toe		29.86
Video Asst.		29.86

<b>Accessories</b>		
<b>Le Stick</b>		39.95
Driving Controller Pair		21.95
Paddle Controller Pair		21.95
Keyboard Controller Pair		21.95
Joystick Controller Single		10.95
AC Adapter		9.95
Switch Box		9.95
Atari Game Program Case		9.95
Atari Modular Cartridge Library		14.95
Atari Game Center		39.95

<b>Atari Home Computers</b>		
Specify cassette or disk when ordering.		
<b>Atari 400</b>		269.86
<b>Atari 800</b>		649.86
Program Recorder		63.86
Disk Drive		49.86
40 Col. Impact Printer		286.86
40 Col. Thermal Printer		286.86
80 Col. Impact Printer		668.86
Acoustic Modem		168.86
Interface Module		185.86
Numerical Keypad		109.86
Memory Module		30.86
Paddle Controller Pair		21.86
Joystick Controller Single		10.86
<b>Education Programs</b>		
Speed Reading		61.86
Biorhythm		12.86
Conversational French		48.86
Conversational German		48.86
Conversational Italian		48.86

<b>Texas Instruments Computers</b>		
<b>Model TI-99/4A</b>		219.86*
*after rebate (you send 319.86)		
Cassette Cables		14.86
Joysticks		34.86
Speech Synthesizer		124.86*
*Free w/ purchase of 6 software		
10" Color Monitor		387.86
Peripheral Expansion Sys 210.86		
RS232 Card		147.86
Disk Controller Card		210.86
Expansion Disk Drive		336.86
Memory Expansion Card		249.86
Telephone Modem		189.86
80-Column Printer		595.86
<b>Mgmt./Fin. Programs</b>		
Home Finance		25.86
Household Budget		33.86
Securities Analysis		45.86
Personal Record Keeping		42.86
Tax Investments		58.86
Personal Real Estate		58.86

<b>Education Programs</b>		
Early Learning Fun		24.86
Beginning Grammar		33.86
Number Magic		16.86
Early Reading		45.86
Add & Subtract 1		33.86
Add & Subtract 2		33.86
Multiplication		33.86
Teach Yourself Basic		25.86
Teach Yourself Ext. Basic		16.86
Video Chess		49.86
Weight Control & Nutrition		49.86
TI Logo		63.86
Reading Fun		45.86

<b>Entertainment</b>		
<b>Football</b>		25.86
Indoor Soccer		25.86
A-Mazing		23.86
Tomestone		31.86
TI Invaders		33.86
Car Wars		33.86
Manchman		33.86
The Attack		33.86
Blasto		33.86
Hunt the Wumpus		21.86
Blackjack & Poker		21.86
Hustle		21.86
Connect Four		16.86
Adventure		42.86

<b>Handhelds</b>		
Dungeons and Dragons		23.86
Armor Battle		33.86
Space Battle		33.86
Formula Race		33.86
Long Bomb Football		28.86
Competition Football		20.86
World Champ Football		62.86
World Champ Baseball		62.86
World Champ		99.86
Computer Backgammon		53.86
Synopsis Drums		118.86
Diets		37.86
Basketball 2 (Dec)		35.86

<b>Other Programs</b>		
Statistics		37.86
Extended Basic		83.86
Terminal Emulator 2		42.86
Assembler		83.86
Mini Memory		83.86
Speech Editor		37.86

<b>20th Century Fox</b>		
<b>Fits Atari</b>		
Warm War I		23.86
Bennie Bopper		23.86
Fast Eddie		19.86
Deadly Duck		19.86
<b>U.S. Games</b>		
(Vidtec) Fits Atari		
Weird Bird (Jan)		22.86
Squeeze Box (Oct)		22.86
VC 1007 (Oct)		22.86
Guard of Treasure (Nov)		22.86
Towering Inferno (Nov)		22.86
Gopher Attack (Dec)		22.86
Maze Chase (Oct)		22.86
Space Jackey		18.86
Sneek & Peek		22.86
Ward Zapper		22.86
Commando Raid		22.86
Missile Intercept (Aug)		22.86
Catch (Aug)		22.86
The Fly (Sept)		22.86
Darts (Sept)		22.86

<b>Most Orders Shipped Within 14 Days</b>		
<b>Odyssey</b>		
<b>Master Component</b>		129.86
Video Module		72.86
Sid the Spellbinder (Voice)		43.86
Numbers and Nibble (No)		43.86
Type and Tell (Voice)		33.86
K.C.'s Crazy Chase (Voice)		30.86
Smitherens (Voice) (Nov)		30.86
Acrobat (Voice) (Nov)		30.86
Creature (Voice) (Nov)		30.86
Arcade (Voice) (Nov)		30.86
Las Vegas Blackjack		19.86
Football		19.86
Armored Encounter/Sub Chase		19.86
Bowling/Basketball		19.86
Math A-Magic/Echo		19.86
Computer A-Magic		19.86
Baseball/Logix/Buzzword		19.86
Baseball		19.86
Computer Golf		19.86
Cosmic Conflict		19.86
Take the Money / Run		14.86
I've Got Your Number		14.86
Invaders from Hyperspace		19.86
Thunderball		19.86
Shutdown in 2100 A.D.		19.86
War of Wives		19.86
Alpine Skiing		19.86
Helicopter Rescue/Out of This World		19.86
Hockey/Soccer		19.86

<b>U.S. Games</b>		
<b>(Vidtec) Fits Atari</b>		
Weird Bird (Jan)		22.86
Squeeze Box (Oct)		22.86
VC 1007 (Oct)		22.86
Guard of Treasure (Nov)		22.86
Towering Inferno (Nov)		22.86
Gopher Attack (Dec)		22.86
Maze Chase (Oct)		22.86
Space Jackey		18.86
Sneek & Peek		22.86
Ward Zapper		22.86
Commando Raid		22.86
Missile Intercept (Aug)		22.86
Catch (Aug)		22.86
The Fly (Sept)		22.86
Darts (Sept)		22.86
<b>TigerVision</b>		
<b>Fits Atari</b>		
King Kong		23.86
Jaw Breakers		29.86
Treshold (Sept)		34.86
River Patrol (Aug)		18.86
Marauder (Oct)		18.86

<b>Dynasty</b>		14.86
Volleyball		19.86
Foosball		14.86
Pocket Billiards		19.86
Pachinko		19.86
Slot Machine		19.86
Blastout		19.86
Alien Invaders		19.86
Quest for the Rings		43.86
UFO		27.86
Conquest of the World		27.86
Monkeyshines		19.86
Message Center		27.86
Great Wall Street Fortune		27.86
Hunt		43.86
TV/Game Switch		14.95
Pickaxe Pete		29.86
Freedom Fighter		29.86

<b>WRITE FOR FREE CATALOG</b>		
<b>Astrocade</b>		
<b>Master Component</b>		239.86
Includes 4 built-in games!		
Hand Controls (ea.)		27.86
ZZZZzap/Dodgem		21.86
SeaWolf/Missile		21.86
Planer Attack/Red Baron		25.86
Clowns/Brickyard		25.86
Star Battle		21.86
Astro Battle		25.86
Dog Patch		25.86
Galactic Invasion		25.86
Space Fortress		25.86
Grand Prix		25.86
Pirate Chase		25.86
Munchie (1983)		28.86
The Wizard (1983)		28.86
Solar Conqueror		28.86
Cosmic Raiders/Defenders		28.86
Bowling/Tennis/Hockey/Football		25.86
Booly Pin		25.86
Bingo Math/Speed Math		21.86
Letter Match/Spell 'n' Score/Crosswords		25.86
Music Maker I		47.86
Biorhythm/Calendar		25.86
Coloring book with light pen		47.86
Coloring book		28.86
Amazon Maze/Tic Tac Toe		21.86
Black Jack/Poker		25.86
Acety Ducky		25.86
Quest for the Orb		28.86
Monkey Kong		9.86
Space Gauntlet/Quadron		11.86
Omega Valley/Astro Terror		11.86
Vindicator/Cruncher		10.86
Vindicator/Art Show		10.86
Fireworks		10.86
Max Robot from Space/Horseace		9.86
Clue/Flying Ace		9.86
Maze Race/Obstacle Course/Space Chess		9.86
Slot Machine/Perseverance		9.86
Music Composer/Yantzee		9.86
Notematch		9.86
Guitar Course/Tuning/Note Match/Chord Progressing		19.86
Background/Obstacle Course/Tournament		14.86
Pack Rat I & II		9.86
Lookout for the Bull I & II		9.86
Whiz Quiz (Trivia)		11.86
Castle of Horror		9.86

<b></b>
---------



# SKIL-STIK™



PAT. PEND.

FOR USE WITH INTELLIVISION™  
AND SEARS SUPER VIDEO ARCADE™

- More Control
- Higher Scoring
- Simple to Attach
- Improve Skill
- Greater Accuracy
- Less Fatigue

**\$599** PLUS  
65¢ PAIR POSTAGE

DISTRIBUTOR COST INFORMATION  
WRITE OR CALL (401) 331-3200

## C&T CREATIONS

127 Weybosset St., Providence, RI 02903  
(PLEASE PRINT)

NAME \_\_\_\_\_

ADDRESS \_\_\_\_\_

CITY \_\_\_\_\_

STATE \_\_\_\_\_ ZIP \_\_\_\_\_

Send check or money order - Sorry no C.O.D.'s

# THE 'GRAND' STAND™

JOYSTICK  
STABILIZER  
SUPPORT &  
SCORE  
ENHANCER.

Constructed of all solid wood with fine walnut finish.

Exotic hard woods available at extra cost.

ADAPTS TO ALL POPULAR JOY STICKS

THE PERFECT GIFT for the avid video gamer and an attractive addition to your TV game machine.

**\$34.95** each Two for \$64.95 Add sales tax Add \$2.50 shipping charge

CHECK OR MONEY ORDER TO  
**THE GRAND STAND CO.**

4231 BLUEBELL AVE., STUDIO CITY, CA 91604

MASTERCARD  VISA EXPIRATION DATE \_\_\_\_\_

SIGNATURE \_\_\_\_\_

NAME (PRINT) \_\_\_\_\_

ADDRESS \_\_\_\_\_

CITY \_\_\_\_\_ STATE \_\_\_\_\_ ZIP \_\_\_\_\_

# E.G. READERS PICK THEIR FAVORITE GAMES

## ★ Most Popular Videogame Cartridges ★

Position		Game	System	Manufacturer
This Month	Last Month			
1	1	Defender	Atari VCS	Atari
2	6	Adventure	Atari VCS	Atari
3	5	Major League Baseball	Intellivision	Mattel
4	8	Night Stalker	Intellivision	Mattel
5	-	Berzerk	Atari VCS	Atari
6	9	Demon Attack	Atari VCS	Imagic
7	-	Star Master	Atari VCS	Activision
8	4	Pac-Man	Atari VCS	Atari
9	14	Yars' Revenge	Atari VCS	Atari
10	10	K.C. Munchkin	Odyssey <sup>2</sup>	Odyssey
11	-	Star Strike	Intellivision	Mattel
12	3	Chopper Command	Atari VCS	Activision
13	-	Pick Axe Pete	Odyssey <sup>2</sup>	Odyssey
14	7	Missile Command	Atari VCS	Atari
15	-	Frogger	Atari VCS	Parker Brothers

## ★ Most Popular Computer Programs ★

Position		Game	System	Manufacturer
This Month	Last Month			
1	1	Star Raiders	Atari 400/800	Atari
2	4	Castle Wolfenstein	Apple II	Muse
3	3	Pac-Man	Atari 400/800	Atari
4	2	Missile Command	Atari 400/800	Atari
5	5	Jawbreaker	Atari 400/800	On-Line
6	-	Wizardry	Apple II	Sir-Tech
7	-	Asteroids	Atari 400/800	Atari
8	-	Ghost Hunter	Atari 400/800	Arcade Plus
9	10	Protector	Atari 400/800	Synapse
10	9	Empire of the Over-Mind	Atari, Apple II, TRS-80	Avalon Hill

## ★ Most Popular Coin-Op Videogames ★

Position		Game	Manufacturer
This Month	Last Month		
1	1	Donkey Kong	Nintendo
2	6	Tron	Midway
3	8	Dig-Dug	Atari
4	4	Ms. Pac-Man	Midway
5	9	Robotron	Williams
6	5	Pac-Man	Namco/Midway
7	2	Tempest	Atari
8	3	Zaxxon	Sega/Gremlin
9	-	Centipede	Atari
10	-	Berzerk	Stern

## Readers Choose Top Games

Since mere quantity of play doesn't necessarily equal actual popularity, **Electronic Games** bases its standings on the votes of its readers. These lists of most popular games are based on the more than 800 Reader Polls. We update the "picked hits" lists in every issue of **Electronic Games**.

So send in your votes!



ALL ORDERS  
SHIPPED FROM  
STOCK WITHIN  
24 HOURS

# VIDEO HEAVEN, INC.

NEW  
TITLES  
DAILY

ALL THE GAME CARTRIDGES FIRST! AT THE LOWEST PRICE ANYWHERE!

**Intellivision**  
Intelligent Television  
**INTELLIVOICE CARTRIDGES**  
—SPACE SPARTANS  
—BOMB SQUAD  
—B-17 BOMBER  
—TRON SOLAR SAILOR  
(AVAIL. NOV. 15)



59<sup>95</sup>



29<sup>95</sup> EACH

27<sup>95</sup>



23<sup>95</sup>

27<sup>95</sup>



18<sup>95</sup>

Matell  
FROG BOG



27<sup>95</sup>

Matell  
DUNGEONS & DRAGONS

**PARKER BROTHERS**  
(FOR ATARI)



25<sup>95</sup> EACH



STAR WARS AMIDAR

Now! Activision® made for your Intellivision®!  
(FOR INTELLIVISION)



STAMPEDE

23<sup>50</sup> EACH



PITFALL

**ACTIVISION**  
(FOR ATARI)



PITFALL & MEGAMANIA

23<sup>50</sup> EACH



STAR-MASTER & CHOPPER COMMAND

**M NETWORK**  
(FOR ATARI)

- LOCK n CHASE - 28<sup>95</sup>
- ASTRO BLAST - 24<sup>95</sup>
- BASEBALL - 24<sup>95</sup>
- FOOTBALL - 24<sup>95</sup>
- FROGS N FLIES - 21<sup>95</sup>
- HIGH SEAS - 27<sup>95</sup>
- DARK CAVERN - 28<sup>95</sup>
- INTERN. SOCCER - 24<sup>95</sup>
- TRON DEADLY - 28<sup>95</sup>
- DISC (avail. Nov. 15)

**IMAGIC**



21<sup>95</sup>



18<sup>95</sup>



21<sup>95</sup>



21<sup>95</sup>

**IMAGIC CARTRIDGES FOR MATTELL**



BERSEK - 22<sup>95</sup>

STAR RAIDERS - 25<sup>95</sup>

REAL SPORTS:  
BASEBALL - 25<sup>95</sup>  
VOLLEYBALL - 25<sup>95</sup>

Coming Dec 1 - E.T. - 28<sup>95</sup>

DEMON ATTACK  
ATLANTIS  
SWORDS & SERPENTS

25<sup>95</sup> EACH

WE STOCK ATARI, MATTEL, IMAGIC, COLECO, US GAMES APPOLLO, SPECTRA VISION, ACTIVISION, M-NETWORK, COMA-VID, AND A COMPLETE LINE OF GAME ACCESSORIES. — CALL FOR NEW RELEASES AND SUPER SPECIALS.

TO ORDER CALL  
1-800-253-0164  
(in MICHIGAN 616-335-5056)

or send Money Order / Certified Check with \$2.00 shipping for total order.  
WE ACCEPT VISA, MASTERCARD, AMERICAN EXPRESS  
P.O. Box 144-C HOLLAND, MICHIGAN 49423

SEND STAMP  
FOR CATALOG

## QUESTAR

World's Finest Game Controllers

### Questar™ I button console

Use with any game instead of a joystick. Built with genuine arcade buttons, the same size and the same spring tension as coin-op games

\$34.95

### Questar™ II joystick console

Discover the speed of a console mounted joystick. 2 Rapid-Fire buttons allow both right and left handed play. Grab onto this short throw, 8 way joystick for fast accurate control.

\$39.95

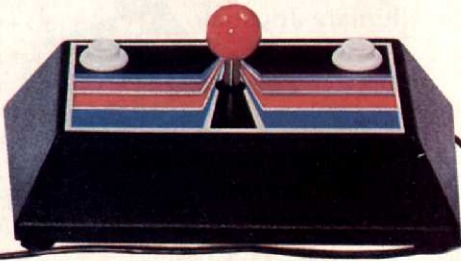

YES! Here's my order. Send me: **QUESTAR**

Questar I @ \$34.95 ea.  
Questar II @ \$39.95 ea.  
Plus \$2.00 Postage & Handling  
WA residents add 6% Sales Tax

Name \_\_\_\_\_  
Address \_\_\_\_\_  
City \_\_\_\_\_ State \_\_\_\_\_ Zip \_\_\_\_\_  
Check \_\_\_\_\_ Mastercard \_\_\_\_\_ Visa \_\_\_\_\_ Exp. Date \_\_\_\_\_  
Account Number \_\_\_\_\_

DIRECT PLUG-IN TO Atari® VCS™, 400™, 800™, Colecovision™\*, Commodore™ & Sears Video Arcades™.

Questar™ consoles make any game an arcade game. They are faster and more comfortable than hand-held joysticks. Your concentration will be better, your scores will be higher and you'll have more fun than ever before. Ask your local dealer or order direct from:

Quest Industries, Inc., 670 N.W. Penn Ave., Chehalis, WA 98532  
Phone Orders 206-748-8614

Order now for Pre-Christmas delivery.

\*except Cosmic Avenger Game

© 1982 Quest Industries, Inc.



# COMPUGAMES INC.

— For the Serious Electronic Gamer —



ATARI  
VCS, 400 and 800,  
APPLE, INTELLIVISION, TRS,  
ODYSSEY, BALLY, PET  
and more at VERY LOW prices

We carry full lines of  
Game Computers, Cartridges,  
Storage Cases, Cassette and  
Disk Games, Joysticks and other  
game accessories all Near Wholesale!

Join COMPUGAMERS CLUB. Take advantage of  
Greater Discounts and Freebies. Details in catalog.  
Allow 2-4 Weeks. Photocopied Coupon Accepted.

**30 DAY - 100% GUARANTEE**  
On All Items

Clip this ad and mail along with  
\$2.00 for Catalog and Price Lists.  
You'll be glad you did!!!

NAME \_\_\_\_\_  
STREET \_\_\_\_\_  
CITY \_\_\_\_\_ STATE \_\_\_\_\_  
ZIP \_\_\_\_\_

Mail To:  
**COMPUGAMES, INC.**  
Catalog Dept.  
P.O. Box 190  
Enfield, CT 06082

Check or M.O. only C-2

## READER REPLAY

Continued from page 16

few people are interested in" (especially in light of the nationwide tournament held this past summer), EG tries to confine "Strategy Session" to games that have been on the shelves for a month or two. It's our feeling that readers prefer to read strategy pieces concerning games with which they are familiar. Once all the basic play mechanics are mastered, it's time to look at how the heavy gamers do it.

It's a tough job, but EG tries to cover the field in proportion to the popularity of the various home systems. There are simply more VCS units out there than Intellivisions.

### COLECO CAVEAT

I recently purchased Donkey Kong by Coleco. One night I was watching TV and the commercial for it came on and the game on TV looked just like the coin-op, so I thought about it for a bit, and then decided to get it. When I hooked it up to my Atari VCS, I was really quite surprised to find that it wasn't at all as it was advertised. I think this fits in with the Gamer's Bill of Rights!

Aaron Peters  
San Ramon, CA

Ed: This is quite a tricky bit of business, Aaron. You see, Coleco produces versions of its various titles for the VCS, Intellivision and its own ColecoVision edition, a fact which that same ad prominently announces. The VCS adaptation is an excellent effort, but the ColecoVision version is simply better, featuring magnificent arcade-level sound and graphics as well as three scenarios. Buyers of versions of Coleco cartridges for other systems might want to check the games out before purchase.

### ZX-81 LOWDOWN

I am interested in creating and programming computer games but we can't afford any large home computers such as the Atari 400/800 and Apple II. I have the BASIC cart for the VCS, but it does not offer much memory at all. Recently, I found what appeared to be an answer to my problem . . . a personal home computer for \$99.95. After reading the ad, I think it's just what I need but my parents don't think it will do what it says! Can the Sinclair ZX-81 really handle game program-

## YOU'RE NOT GOING TO BELIEVE—

**OUR LOW-LOW PRICES ON VIDEO GAMES,  
CARTRIDGES, COMPUTERS + ACCESSORIES**

ATARI™ • ACTIVISION™ • APOLLO™ •

IMAGIC™ • COLECO™ • MATTEL™

PARKER BROTHERS™ • VIDTEC™ • BREAKTHROUGH™

ODYSSEY™ • & MORE!!!

**MOST ORDERS SHIPPED FOLLOWING DAY RECEIVED!!!**

SEND 25¢ FOR COMPLETE PRICE LISTS

**MAXARON HOME ENTERTAINMENT**

**22932 VAN DYKE, WARREN, MI 48089**

**(313) 758-7884**

**MASTERCARD / VISA**  
• OPEN 7 DAYS •

## ComputAbility

presents the Newest in Joystick Products

### Starfighter™

The Ultimate Joystick

- 2 Year Warranty
- More Accurate
- Easier to Hold

**\$16.95**



### SLIK STIK™

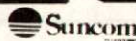

- 90 Day Warranty
- Easy Ball Top Control.

**\$9.95**



### LEFTY JOYSTICK ADAPTOR

Adapts to any Atari Joystick.  
Moves fire button to top Right.

**\$9.95**

### EXTENSION CABLE (5 ft.)

Adapts to any Atari controller.

**\$6.95**

ALL JOYSTICKS WORK WITH: Atari VCS, Sears Telegame, Commodore VIC-20, Atari 400/800

(All products have registered trademarks)

### 30 Day Money Back Guarantee

Also carry a large selection of Atari 400/800 software.

Master Card/VISA  
Order Toll Free

**800-558-0003**

In Wisc. Call  
**1-414/351-2007**

### ORDERING INFORMATION:

To order by mail send money order, certified check or personal check (allow 14 days to clear) to COMPUTABILITY. Include \$2.50 shipping. Mastercard & VISA please include card number and expiration date. WI residents please add 5% sales tax. Outside of continental U.S.A. please add 15% shipping (U.S. Funds only). Prices subject to change without notice.

Order Hours: 12 pm - 9 pm  
Mon. - Fri.  
C.S.T.

ComputAbility  
P.O. Box 17882  
Milwaukee, WI 53217



# Thumbs that play together stay together.

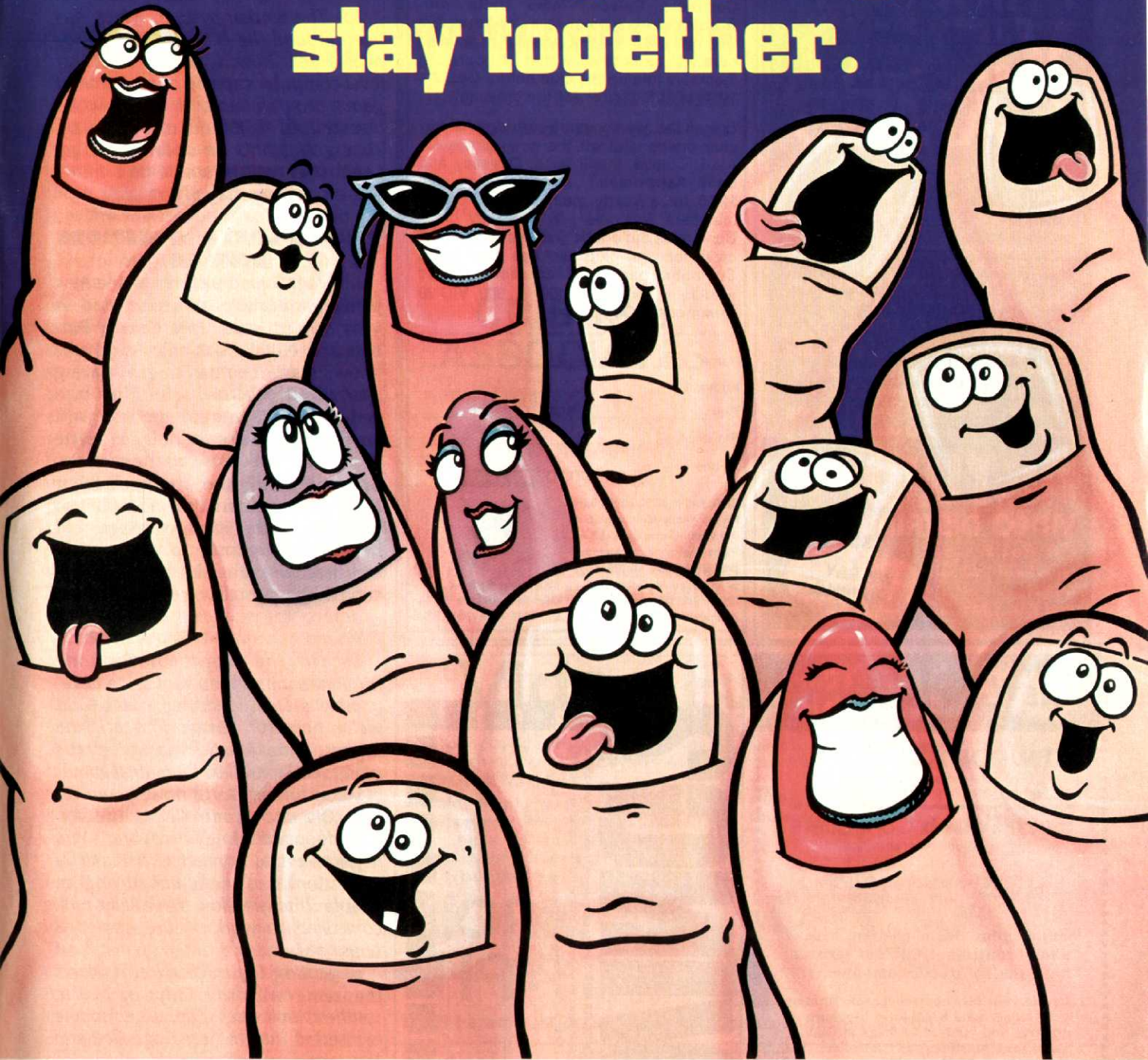

Liquid Crystal pocket-sized Thumb Games™ are the perfect recreation for those forgotten fifth digits.

Dare your dexterity with any one of eight thumb-thrilling mini-arcade classics.

Hands-on therapy for appendages of all ages, complete with a digital clock for those who never have enough time.

© 1982 THUMB POWER™



You'll probably start wishing you were all thumbs.

Thumb Games™, by Masudaya, are exclusively distributed by Thumb Power™.

Available at fine stores everywhere.

**THUMB POWER™**  
1185 Chess Drive  
San Mateo, CA 94404  
(415) 574-3146





# FANTASTIC PRICES ON VIDEO GAMES

Complete lines of

ATARI	MATTEL
ACTIVISION	COLECO
APOLLO	ASTROCADE
BREAKTHROUGH	VID-TEC
SPECTRAVISION	DATA AGE
20th CENTURY FOX	TIGERVISION
PARKER BROTHERS	IMAGIC

with more to come!!

For Catalogue, Price List and Newsletter with information on ALL New Games send \$1.00 (refundable with first order) along with name and address to:

## NETWORK VIDEO DISTRIBUTORS

P O Box P  
Newfield, NJ  
08344  
609-696-1861

WE PAY SHIPPING

### Hey Kids Of All Ages!

Video Game Club USA Announces its Xmas drawing for the membership. 2 Complete Coleco Home Units with Accessories will be given away Xmas Eve Dec. 24, 1982 at 9 PM Arizona time. Winners will be notified within 24 hours. All members joining the club before Dec. 24, 1982 will be eligible for the drawing.

Buy all the newest game cartridges at low club prices. Get all the new games for Atari, Coleco, Intellivision, Odyssey and Bally Astrovision. Join Now for only \$2.50 for a yearly membership. Foreign members welcome (US Currency only). Don't miss out on the great savings. Send away for your club package right away. Computer parts and accessories also available for Atari 400 & 800, VIC 20 Commodore Computer.

Name \_\_\_\_\_  
Address \_\_\_\_\_  
City \_\_\_\_\_ State \_\_\_\_\_ Zip \_\_\_\_\_  
Player of \_\_\_\_\_  
Phone ( ) \_\_\_\_\_

Enclosed is \$2.50 US Dollars for my Yearly Membership in the Video Game Club U.S.A. Please send me my Membership Card and Club Package of Prices of All Game Cartridges and Accessories Available in the Club.

Mail To VGC USA



4501 West Aster Dr.  
Glendale, Arizona 85304  
978-3135 Area Code 602

ming? I'm sure others would like to know as well.

Brett Nicholson  
Little Rock, AR

*Ed: The Sinclair system, which has been around the U.S. and Europe for over a year now, is an introductory-level computer capable of very limited game programming. It can now be boosted to 16K and is owned by Timex. Watch for an upcoming "Test Lab" that will examine the mini-system under a magnifying glass.*

### WHOLE LOTTA' QUESTIONS GOIN' ON

I have included pictures of the new pinball simulations you discussed in your August issue (**Zero Gravity Pinball** and **Night Mission**). As you all know, many companies are making specialized controllers for the Atari systems (2600 and computers). Will anyone be making a "trigger"-style joystick, such as those on the coin-ops **Gorf** and **Tron**? Also, the Intellivision Master Component has a "hole" in which to fit the game cartridge, but how is one supposed to fit the game cart in it when the slot is already occupied by an Intellivoice unit?

Dan Jung  
San Mateo, CA

*Ed: In the words of Rosanne Rosannadanna, "You sure ask a lotta' questions, Dan!" But then, that's what we're here for. Okay, first off, the trigger-format joysticks are indeed the most ideal controllers for pinball games in video format. As of now, however, the only such controller is the Astrocade paddle-joystick hybrid. You might want to contact Cliff Blake of Screenonics to see about buying an adapter that will allow these Bally-built controllers to work on the Atari systems.*

*Regarding the Intellivoice, it works the same way the Odyssey<sup>2</sup> voice synthesis unit does. The voice module is inserted into the cartridge slot and the cartridge is plugged into the voice unit. The only difference between the two systems is that the O<sup>2</sup> voice contests can be played either with or without the chatter while the talking Intellivision games are a separate, non-compatible line.*

And that about wraps things up for this issue's reader feedback. We at EG never cease to be impressed at the volume, quality and enthusiasm demonstrated by our truly special readers. Thanks.

## NEW Kits Now Available

**NEWPORT "Pro-Sticks"**  
the Mercedes of Joysticks  
*'Creative Computing Magazine' Aug. 1982*

**Soft-Touch Controllers**  
for busy fingers and fast action

**NEW** Extension "Y" Adapters  
with rapid fire action

Build your own custom video-game controls from our proven high quality arcade components.

Create your own control console right in your home. Send \$3.00 for a brochure of creative and innovative ideas in custom video game joysticks and controllers. Includes easy to follow schematics and instructions for Atari, Apple, Pet Commodor, TSR-80, and other computers, and a complete kit and components price list.

INQUIRE ABOUT OUR CLUB DISCOUNTS

Please rush me \_\_\_\_\_ brochures at \$3.00 each (includes First Class Mail and handling) and mail to:

Name \_\_\_\_\_  
Address \_\_\_\_\_  
City \_\_\_\_\_ State \_\_\_\_\_ Zip \_\_\_\_\_

**NEWPORT MACHINE DESIGN**  
P. O. Box 418, Bishop, CA 93514  
(714) 873-5677

# WOWINGS?

Don't risk missing an issue of **ELECTRONIC GAMES**. If you're planning on changing your address, please give us 8 weeks notice. Simply write in your new address below and mail this coupon—ALONG WITH YOUR SUBSCRIPTION MAILING LABEL—to:

**Electronic Games**  
Subscriber Services  
P.O. Box 1128, Dover, NJ 07801

(please print)  
Name \_\_\_\_\_  
Address \_\_\_\_\_  
City \_\_\_\_\_ State \_\_\_\_\_ Zip \_\_\_\_\_



# COMPUTER GAMING

Continued from page 80

## MOONBASE 10

PDI/Atari 400 & 800/16K cassette, 32K disc (with cassette)

You have awakened from a deep sleep," a voice intones at the beginning of *Moonbase 10*. On the playfield there is a portal looking out into deep space. A computer guidance console lines the wall of your ship, the Juno 9.

PDI, the software producer responsible for *Moonbase 10*, has done more for the "talking videogame" than anyone else in the field. Without sophisticated speech-synthesis chips or any other high-tech wizardry, PDI has consistently experimented with the integration of spoken word and videogame action in their Atari computer software. The designers' only tool has been the Atari 410, the specially-modified tape recorder used to load programs on audio-cassette format.

*Moonbase 10* further evolves the use of audiotape in game-playing—even the disc version comes with a cassette! The arcader is the pilot, playing a series of machine-language arcade contests in order to secure the three moons and their transmitters.

Phase one involves blasting through a field of space deathtraps with limited energy and firepower. The ship must then be steered in orbit around the satellite and docked for refueling. A multi-staged high-quality invader game follows before the Juno 9 can cross the plains of the final moon.

After each successful phase—losers must go back to square one—hearty congratulations are relayed from a chattering control room back on Earth. The final command is then issued: go in after the mothership itself. Fragmentary reports from the few previous pilots who got this far reported that the big ship was protected by "breakout shields" which must be blown up one layer at a time.

Should you actually wipe out the mothership you will hear the screams on board the doomed craft, followed by a personal congrats from the Federation President!

*Moonbase 10* has to be seen—and heard—to be believed. First rate production values are of the highest calibre almost everywhere—if only their packaging were a bit sturdier. . .

(Bill Kunkel)



# ATARI & INTELLIVISION

## USED AND NEW CARTRIDGES

USED-BELOW WHOLESALE & GUARANTEED  
NEW-SO LOW!!!!.....AND DISCOUNTED

FOR PRICING INFORMATION  
SEND 50¢ TO:

## CRIBBS & ASSOCIATES

P.O. BOX 1012  
BEDFORD, TX 76021  
(817) 498-3045  
No Collect calls

WE BUY AND SELL ALL BRANDS  
OF VIDEO GAME SOFTWARE

The MAGIC of  
**BEAMSCOPE**  
more than DOUBLES the size of your  
TV Picture

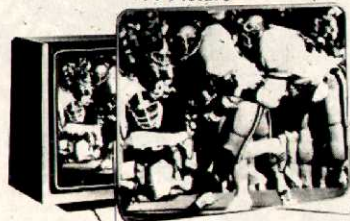

Check these exciting features: • Exceptional Color Clarity • Installs Without Tools • Use Under Normal Lighting • Minimum Floor Space • Affordable Price

Shown below is a size comparison from regular screen to size with BEAMSCOPE™

TV size (Diagonal)	BEAMSCOPE® Model No.	New TV Size (Diagonal)	Percentage of increase
12-15"	TS-25	25	261%-400%
17-19"	TS-30	30	247%-297%
21-25"	TS-41	41	267%-372%

Dealer Inquiries Welcome

ORDERS SHIPPED **DIACO SALES** WITHIN 72 HOURS

1000 Oakton Box 1937EJ Des Plaines, IL 60018

24 Hr. A Day 312-296-3800 - 7 Days A Week

Please Rush  Order  Information

Name \_\_\_\_\_

Address \_\_\_\_\_

City \_\_\_\_\_

State \_\_\_\_\_ Zip \_\_\_\_\_

Phone (\_\_\_\_) \_\_\_\_\_

Payment  Check  C O D \$2.00 Extra

MasterCard  Visa Exp Date \_\_\_\_\_

Card No \_\_\_\_\_

T.S. 25 for 10" to 15" T.V. @ \$59.95 Ea = \$ \_\_\_\_\_

T.S. 30 for 17" to 21" T.V. @ \$69.95 Ea = \$ \_\_\_\_\_

T.S. 41 for Console T.V. 21" to 26" @ \$199.50 Ea = \$ \_\_\_\_\_

T.S. 41 Deluxe @ \$299.50 Ea = \$ \_\_\_\_\_

Swivel Base for T.S. 25 @ \$19.95 Ea = \$ \_\_\_\_\_

Swivel Base for T.S. 30 @ \$21.95 Ea = \$ \_\_\_\_\_

Shipping and Handling Charges \$ 4.50

C O D's Add \$2.00 Extra

SATISFACTION GUARANTEED

OR FULL REFUND

TOTAL \$ \_\_\_\_\_

# Video Furniture?

Of course. If you've ever spent a few uncomfortable hours playing video games or watching TV while seated in conventional furniture, you'll love the Stinchfield Bionic Chair.

Let's face it. Most furniture simply isn't designed to accommodate the video game player. The Stinchfield Bionic Chair is. You actually *fit* in this chair. Your slightest movement alters the position of this perfectly balanced chair.

## BIONIC CHAIR

Call or write for a free full color brochure.  
Toll Free:  
(800) 645-5788  
In California:  
(213) 630-5717

15301 Paramount Boulevard, Paramount, California 90703

It's so well designed and comfortable that chiropractors actually **prescribe** the Stinchfield Bionic Chair for certain patients who suffer low back pain.

From **\$159.95**  
Dealer Inquiries Invited



**LOWEST PRICES IN ATARI AND GAMES FOR ATARI SYSTEM**  
COMPARE AND SEE  
FOR FREE BROCHURE AND PROMPT RESPONSE SEND SELF-ADDRESSED STAMPED ENVELOPE TO:

KINGSWAY VIDEO  
DEPT. EG2  
1690 E. 15th STREET  
BROOKLYN, N.Y. 11229





# THE GALACTIC GAMES EMPORIUM

\* Orders of 5 Games or over 5% discount.

## Galactic Games National Players Club North America's First Games Club.

Join Now!  
Only \$35.00

**HOW TO ORDER BY MAIL:**  
For prompt shipment send money order or certified check (U.S. dollars), VISA,

Mastercard, or American Express. Include card n<sup>o</sup>, expiry date, bank, and signature. Postage, shipping and handling is 5% of total order.

### COMMA VID

Fits Atari

Cosmic Swarm 32.95  
Room of Doom 32.95  
Mines of Minos 32.95  
Mission Omega 32.95  
Underworld 32.95

### APPOLO

Fits Atari

Skeet Shoot 20.95  
Space Chase 29.95  
Space Cavern 29.95  
Racketball 29.95  
Lost Luggage 29.95  
Lock Jaw (Sharks) 29.95

### ACTIVISION

Dragster 21.95  
Boxing 21.95  
Checkers 21.95  
Fishing Derby 21.95  
Skiing 21.95  
Bridge 29.95  
Tennis 21.95  
Laser Blast 21.95  
Freeway 21.95  
Kaboom 21.95  
Stampede 21.95  
Ice Hockey 29.95  
Barnstorming 31.95  
Grand Prix 31.95  
Chopper Command 31.95  
Starmaster 31.95

### TIGERVISION

Fits Atari  
King Kong 29.95  
Jaw Breakers 29.95  
Treshold 20.95  
River Patrol 20.95  
Marauder (Oct) 20.95

### IMAGIC

Fits Atari  
Trick Shot 22.95  
Demon Attack 29.95  
Star Voyager 29.95  
Atlantic 29.95  
Cosmic Ark 22.95  
Fire Fighter 22.95  
Riddle of the Sphinx 29.95  
Video Action Center 29.95

### MATTEL

Master Component 247.95  
AC Adaptor 7.95  
Sea Battle 37.95  
NFL Football 29.95  
Major League Baseball 29.95  
Dungeons & Dragons 37.95  
Space Spartans 41.95  
Astro Smash 30.95  
Snafu 30.95  
Space Armada 30.95  
Arcade 26.95  
B-17 41.95  
Space Hawk 37.95  
Utopia 37.95  
Star Strike 37.95  
Speed Freak 27.95  
Frog Bog 20.95  
Reversi 20.95  
Night Stalker 37.95  
TRON Deadly Disc 30.95  
TRON Mazatron (Oct) 30.95  
TRON Solar Sailor (Oct) 41.95  
Armor Battle 27.95  
Major League Baseball 27.99

### ATARI

Master Component 137.95

### Space War

Super Breakout 29.95  
Defender 35.95  
Warlords 29.95  
Adventure 29.95  
Demons to Dragons 24.95  
Breakout 20.95  
Space Invaders 29.95  
Night Driver 24.95  
Missile Command 29.95  
PacMan 35.95  
Asteroids 35.95  
Yar's Revenge 29.95  
Star Raiders 35.95  
Frog Pond 35.95

### IMAGIC

Fits Mattel  
Demon Attack 32.95  
Atlantis (Oct) 32.95  
Sword & Sorcerers (Oct) 32.95

### ACCESSORIES

Le Stick 37.95  
Paddle Controller Pair 19.95  
Joystick Controller Single 8.95  
AC Adaptor 7.95  
Switch Box 7.95

### ODYSSEY

Master Component 137.95  
Invaders from Hyperspace 20.95  
Thunderball 20.95  
Showdown in 2100 A.D. 20.95  
Hockey / Soccer 20.95  
Volleyball 20.95  
Blastout 20.95  
Alien Invaders 20.95  
Quest for the Rings 47.95  
UFO 27.95  
Conquest of the World 47.95  
Monkeyshines 27.95  
Great Wall Street 47.95  
Fortune Hunt 27.95  
K.C. Munchkin 27.95  
TV / Game Switch 12.95

### U.S. GAMES

Fits Atari  
Space Jockey 22.95  
Sneek & Peek 27.95  
Word Zapper 27.95  
Commando Raid 27.95  
Missile Intercept 27.95  
Catch 27.95  
The Fly 27.95  
Darts 27.95

### PARKERS BROS.

Fits Atari  
The Empire Strikes Back 37.95  
Jaws (Jan 83) 37.95  
James Bond 007 37.95  
Frogger 37.95  
Amidar (Oct) 37.95  
Super Cobra (Oct) 37.95  
Reactor (Oct) 37.95  
Tutankham 37.95  
Sky Skipper (Jan 83) 37.95  
Spiderman (Oct) 37.95

### COMMODORE VIC 20 COMPUTERS

Vic 20 Computer 295.95  
VIC Avenger 27.95  
Superslot 27.95  
VIC Super Alien 27.95  
Jupiter Lander 27.95  
Draw Poker 27.95  
Midnight Drive / Road Race 27.95  
Radar Rat Race 27.95  
Raid on Fort Knox 27.95  
Sargon 11 Chess 37.95  
Pinball Spectacular 37.95  
GORF 37.95  
Omega Race 37.95  
Adventure Land Adv 37.95  
Pirate Cove Adv 37.95  
Mission Impossible Adv 37.95  
The Count Adventure 37.95  
Voodoo Castle Adv 37.95  
The Sky is Falling 37.95  
VIC 20 Super Expander 67.95  
Programmers Aid Cart 57.95

### DATA AGE

Fits Atari  
Encounter at L-5 29.95  
Warplock 29.95  
Sssnake 29.95  
Airlock 29.95  
Survival Run 29.95

### BREAKTHROUGH

Made by Mattel to fit Atari Games  
Pro Football 32.95  
Space Attack 32.95  
Tank Battle 32.95  
TRON Deadly Discs 38.95  
Lock 'n Chase (Oct) 38.95  
Frogs & Flies 28.95  
Big League Baseball 32.95  
Astroblast 32.95  
Dark Cavern 38.95  
International Soccer 32.95

### MAIL TO:

**GALACTIC GAMES  
EMPORIUM**  
5734 Yonge Street,  
WILLOWDALE,  
Ontario Canada  
M2M 3T3

**FREE**  
T-Shirts  
I.D. Cards  
Buttons  
Newsletters

**Q: What is the hardest thing in the world?**  
**A: Tearing yourself away from an EPYX game.**



Nobody but nobody builds more lasting playing value into their computer games than EPYX.

EPYX—computer games thinkers play. EPYX—producers of award-winning games (including "Crush, Crumble and Chomp"; "Dragon's Eye"; "Temple of Apschai"... and dozens of other thinking games.) For Atari,\* Apple,\* Commodore,\* Radio Shack,\* and IBM\* personal computers. EPYX—the leader in computer game quality, creativity, innovation.

You will love them all. Guaranteed. Write or phone for our latest catalog; it's absolutely free...we even pay the postage. Or stop in at your favorite computer dealer. He should have a supply of catalogs and he can also show you some of those marvelous EPYX games in action.

\*The trademarks, respectively, of Atari, Inc.; Apple Computer, Inc.; Commodore International; Tandy Corp.; International Business Machines. And EPYX is the trademark of Automated Simulations, Inc., just so you don't forget.



**AUTOMATED SIMULATIONS**  
1043 Kiel Court  
Sunnyvale, California  
(408) 745-0700



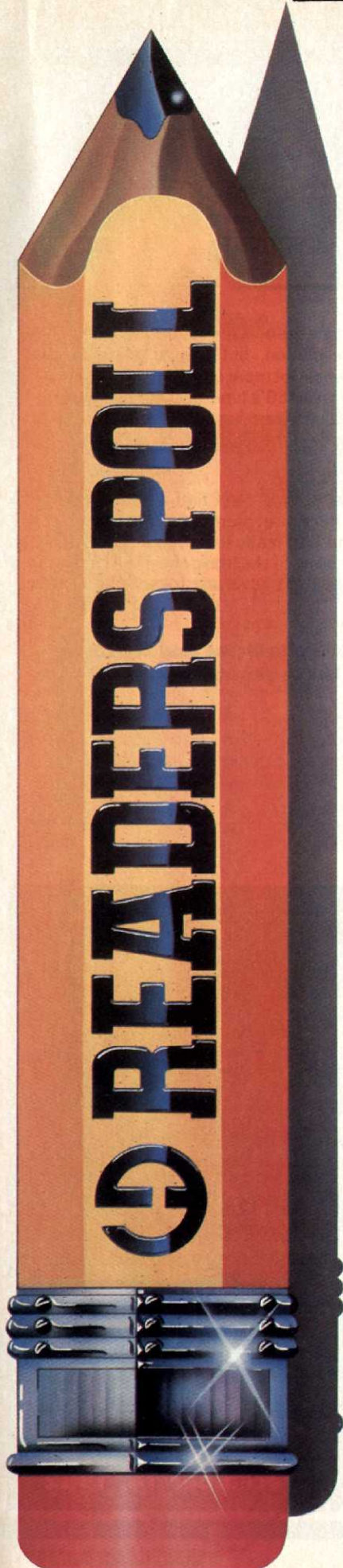

Interaction between the readers and editors of **Electronic Games** helps make this a better magazine. The more we here at **EG** know about who you are and what you want to read, the better we can satisfy your needs and desires. That's why we run a Reader Poll in every single issue of this magazine. Rest assured that even though we protect the anonymity of every respondent to our survey, the editor personally reads each and every ballot received. And of course, this is also your ballot for casting your vote for the most popular videogames, computer game programs and coin-op arcade machines.

Please return this poll sheet—or a photocopy, if you prefer to keep your **Electronic Games** in perfect condition—to: **Electronic Games**, 235 Park Avenue South, New York, N.Y. 10003.

**SEX AND AGE:**

Male  Female Age \_\_\_\_\_

**MARITAL STATUS:**

Single  Married

**HOUSEHOLD INCOME:**

Under \$5000  \$5000-9999  
 \$10,000- 14,999  
 \$15,000- 19,999  
 \$20,000- 24,999  \$25,000+

**NUMBER OF CHILDREN IN HOUSEHOLD: \_\_\_\_\_**

**AGES:**

Under 2  6-11  12-17

Please rate the following features from 1 (awful) to 10 (great):

FEATURE	RATING	FEATURE	RATING
Insert Coin Here	_____	Passport to Adventure	_____
Arcade America	_____	Switch On!	_____
Players Guide	_____	Q&A	_____
E.G. Hotline	_____	Test Lab	_____
Stand-Alone Scene	_____	Strategy Session	_____
Computer Gaming	_____	Inside Gaming	_____
Programmable Parade	_____	Coin-Op Classroom	_____

How many hours per week do you spend playing various electronic games:

Less than 2 hours  2-5 hours  6-10 hours  More than 10 hours

How much do you spend per week on electronic games:

Under \$2  \$2-5  \$6-10  Over \$10

Please rate the following subjects from 1 (no interest) to 10 (great interest):

SUBJECT	RATING	SUBJECT	RATING
Fantasy & Science Fiction	_____	Coin-op games	_____
Sports	_____	Videogames	_____
War games	_____	Computer games	_____

My favorite videogame cartridges are:

- \_\_\_\_\_
- \_\_\_\_\_
- \_\_\_\_\_

My favorite microcomputer games are:

- \_\_\_\_\_
- \_\_\_\_\_
- \_\_\_\_\_

My favorite coin-op games are:

- \_\_\_\_\_
- \_\_\_\_\_
- \_\_\_\_\_





# COMING NEXT IN electronic GAMES

## THE 1983 ARCADE AWARDS

For the fourth consecutive year, the finest videogame cartridges, stand-alone devices, coin-op machines and computer programs will compete for the most coveted honors in the electronic gaming field—the Arcade Awards. The judges have met, their findings are locked in a vault closely guarded by the **Pac-Man** goblins and now all that remains is to rip open the envelopes and read the names of the winners. Will your favorites cop an Arcade Award or Certificate of Merit this year? Match your choices against those of the awards committee in the January issue.

## INSIDE THE ATARI 5200

When the game mavens from Sunnyvale, CA, put their heads together and design an entirely new home arcade machine, that's got to be major news. Is it a bulls-eye or a disappointment? **EG's** editorial staff will delve into every aspect of this fascinating new piece of hardware and the cartridge line created to support it.

## THE PLAYERS GUIDE TO CLIMBING GAMES

The popularity of climbing contests such as **Donkey Kong** and **Crazy Climber** has never been higher. Our January magazine-within-a-magazine casts a critical eye at the whole phenomenon, pointing out the titles that truly scale the pinnacle of gaming excellence and the ones likely to just leave you high and dry.

## THE 21st CENTURY ARCADE

Commercial arcades have changed a lot

since the outbreak of the electronic gaming revolution, but they're going to alter a whole lot more over the next 20 years. Hop aboard **EG's** time machine and pay a visit to a space age fun palace scheduled to open some time in 2001!

## CHESS FOR ONE

When you can't find a human opponent, there are plenty of electronic pawn-pushers ready to test your skill. Our annual review of electronic chess will help you find the right adversary for solitaire sessions.

**There'll be plenty of other exciting articles and features of interest to arcaders, plus these regular columns:**

- ★ **Passport to Adventure**
- ★ **Q&A**
- ★ **Inside Gaming**
- ★ **Arcade America**
- ★ **Computer Gaming**
- ★ **Programmable Parade**
- ★ **Switch On!**
- ★ **New Products**
- ★ **Test Lab**
- ★ **Readers Replay**
- ★ **EG Hotline**
- ★ **Games Library**
- ★ **Stand-Alone Scene**
- ★ **Mini-Arcade Gallery**
- ★ **Coin-Op Classroom**
- ★ **Strategy Session**
- ★ **Insert Coin Here**
- ★ **Pinball Palace**



So watch for the exciting **JANUARY** issue of **ELECTRONIC GAMES**  
**On Sale**  
**December 14, 1982**





# THE WIZARD OF ODYSSEY REVEALS THE KEY TO GREATER CHALLENGE.

*The Keyboard!*

*It makes the fun go further with Odyssey<sup>2</sup> than any other video game. The keyboard lets you program mazes and grids. Type numbers and letters on the screen. Increase skill levels. It even lets you change opponents and fields of play!*

*And only Odyssey<sup>2</sup> offers—The Master Strategy Series™! Each game comes with its own game board. You use it to plan your strategy,*

*input that strategy through the keyboard, and play out the action on your TV screen.*

*Plus, Odyssey<sup>2</sup> offers over 50 games, including arcade, educational, sports and strategy games.*

*So take the word of the Wizard of Odyssey. If you're looking for greater challenge in a video game, look to Odyssey<sup>2</sup>! For your nearest dealer call (800) 447-2882. In Illinois call (800) 322-4400.*



## ODYSSEY<sup>2</sup>

*The keyboard is the key to greater challenge.*





# DON'T TAKE NO FOR AN ANSWER.

## NOW THERE'S ACTIVISION FOR INTELLIVISION™

Now Intellivision™ owners can get all the excitement, fun, challenge, and originality of Activision™ video games.

PITFALL!™ is an incredible jungle adventure game that pits your wits against crocodiles, scorpions, tar pits and tunnels as you struggle to find the treasure.

STAMPEDE™ is a hard-ridin', fast-ropin', rip-snortin', saddle-slappin' roundup that challenges you to herd those dogies 'til you can't herd no more.

Activision™ for Intellivision.™ Now we put YOU in the game.

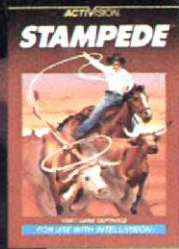

Stampede™ designed by Bob Whitehead.



Pitfall!™ designed by David Crane.

## WE PUT YOU IN THE GAME.

# ACTIVISION®

Mattel Electronics™ and Intellivision™ are trademarks of Mattel, Inc.  
Also for use with the Sears Tele-Games™ Super Video Arcade.  
Tele-Games™ and Super Video Arcade™ are trademarks of Sears, Roebuck and Co.

© 1982 Activision, Inc.